



Artisan Scientific

QUALITY INSTRUMENTATION ... GUARANTEED

Looking for more information?

Visit us on the web at <http://www.artisan-scientific.com> for more information:

- Price Quotations
- Drivers
- Technical Specifications, Manuals and Documentation

Artisan Scientific is Your Source for Quality New and Certified-Used/Pre-owned Equipment

- Tens of Thousands of In-Stock Items
- Hundreds of Manufacturers Supported
- Fast Shipping and Delivery
- Leasing / Monthly Rentals
- Equipment Demos
- Consignment

Service Center Repairs

Experienced Engineers and Technicians on staff in our State-of-the-art Full-Service In-House Service Center Facility

InstraView™ Remote Inspection

Remotely inspect equipment before purchasing with our Innovative InstraView™ website at <http://www.instraview.com>

We buy used equipment! We also offer credit for Buy-Backs and Trade-Ins

Sell your excess, underutilized, and idle used equipment. Contact one of our Customer Service Representatives today!

Talk to a live person: 888-88-SOURCE (888-887-6872) | Contact us by email: sales@artisan-scientific.com | Visit our website: <http://www.artisan-scientific.com>



Anritsu

ME7890B Optical Amplifier Test System

MF9619C Optical Modulator

1530 to 1620 nm



*The photograph shows an example of the system composition.

High-Accuracy NF and Gain Measurement using Optical Pulse Probe Method

Fast, High-Accuracy NF and Gain Measurement

The optical amplifier is a key device in today's high-capacity and long-distance optical communications networks, and evaluation of the optical amplifier noise figure (NF) and gain demands measuring instruments with excellent performance and accuracy.

The ME7890B covers both bands of C-Band and L-Band.

The ME7890B supports this need with fast and high-accuracy of the NF and gain of optical amplifier using the optical pulse probe method.

Optical Pulse Probe Method

The ME7890B uses a combination of the optical pulse method to measure amplified spontaneous emission (ASE) of the optical amplifier with high accuracy, and the optical probe method to measure quickly over a wide wavelength range.

The optical pulse probe method measures the wavelength characteristics using a weak optical signal (probe) that has almost no effect on the locked inversion of the optical amplifier. A saturating signal is input so that the optical amplifier is in exactly the same condition as when it is in actual use.

At evaluation of an optical amplifier for wavelength division multiplexing (WDM) communications, fewer saturating signals are substituted for the WDM light source, creating the same conditions as when a WDM optical signal is input. The probe signal light is used to measure the NF and gain, and then a wavelength tunable laser source or a wide-band light source is used for measurement over a wide wavelength range.

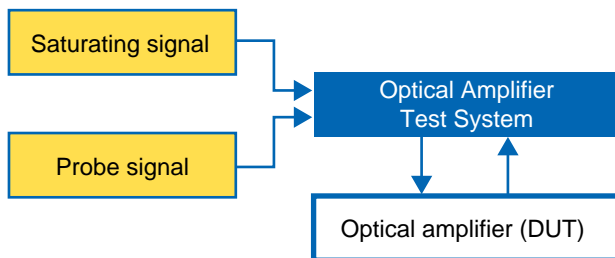

High-Speed Measurement

When a tunable laser source is used as the probe light, the NF and gain wavelength characteristics can be measured in high-speed and synchronizing the wavelength of the probe source output to the OSA sweep. In addition, if a broadband light source such as an SLD is used as the probe light source.

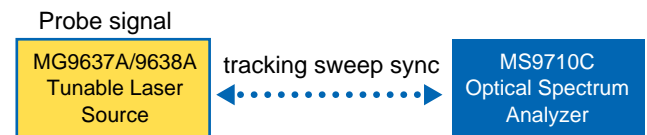

Low Cost

Evaluation of optical amplifier NF and gain requires evaluation under actual working conditions. Actual working conditions for an optical amplifier used in WDM communications systems require a multi-channel light source. With the ME7890B optical pulse probe method, one to several saturating optical signals is input to the optical amplifier to create a condition identical to that at WDM optical signal input. Then the characteristics are evaluated from the response when the probe optical signal is input. This means that manufacturing and inspection lines do not require multi-channel light sources, contributing to reduce facility costs and adjustment man-day.

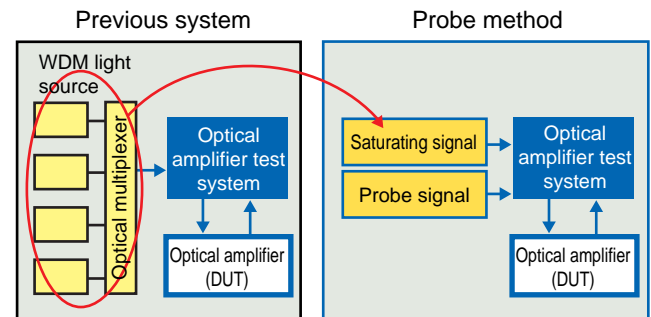

at Low Cost Supports Optical Pulse Probe Method

High Accuracy

A precondition of the probe method is that the power of the probe light is so small that it has no effect on the locked inversion of the optical amplifier. However, if it is too small, it is affected by the noise and the measurement accuracy drops. When using a broadband light source as the probe light, when an optical power that produces sufficient measurement accuracy is input, the optical amplifier conditions change because the total power of the broadband light source is large. To solve this problem, the ME7890B supports the use of the MG9637A/9638A Tunable Laser Source as the probe light.

In this way, only the required optical power for the wavelength component is input to the optical amplifier. This method permits the input of the smallest optical power having no effect on the optical amplifier conditions, while simultaneously achieving a measurement accuracy equivalent to the optical pulse method.

The following graph shows the effect of the probe power on the measurement results by comparing data when a tunable laser source and an SLD light source are used as the probe light source. In this example, the measurement accuracy is about 0.03 dB when a tunable laser source is used as probe signal with more than 30 dB level difference from the saturating signal power.

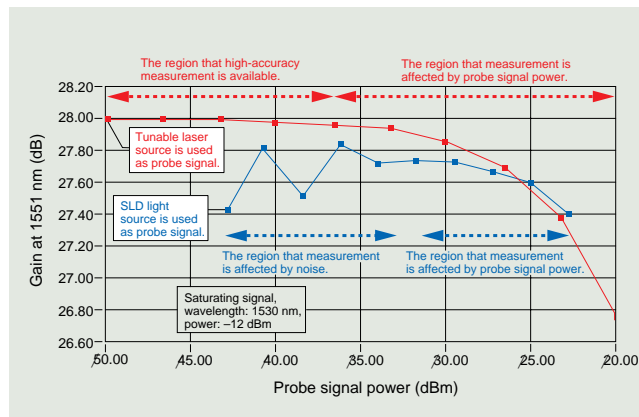

Additionally, the following graph compares the gain measured by the pulse and probe methods using a 16-channel WDM light source. Almost the same gain wavelength characteristics are obtained by substituting a single-channel saturating signal with the same total power as the 16-channel WDM light source.

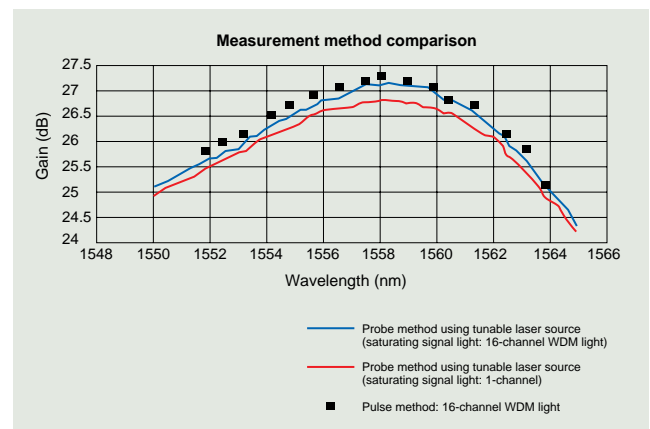

The measurement error when the number of optical saturating signals becomes smaller depends on the characteristics of the optical amplifier under test, as well as on the appropriately number of saturating signals, the wavelengths, power, and probe signal power. These parameters must be determined in comparison with measurement results obtained by the pulse method.

Supports Various Measurement Systems

The wavelength and power are set automatically when using MG9638A (or MG9637A) as the light source for saturating signal. In addition, both WDM light sources (MT9812B) and fixed-wavelength light sources can be used.

The system setup and GPIB address are easily set at the setup panel.

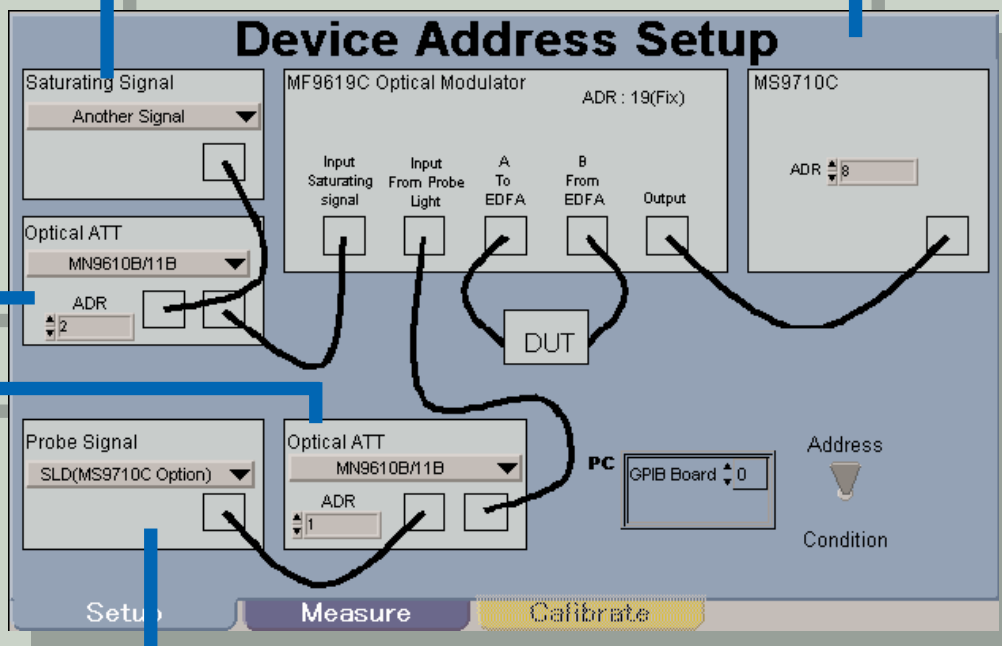

The power is set automatically when using the MN9610B (or MN9611B) Programmable Optical Attenuator. Optical attenuator is not required when the power adjustment is not needed.

When the MG9637A (or MG9638A) Tunable Laser Source is used as the probe light source, the measurement accuracy is equivalent to optical pulse method. Furthermore, the SLD light source output (option) of the MS9710C Optical Spectrum Analyzer as well as other wide-band light sources can also be used.

Standard Configuration

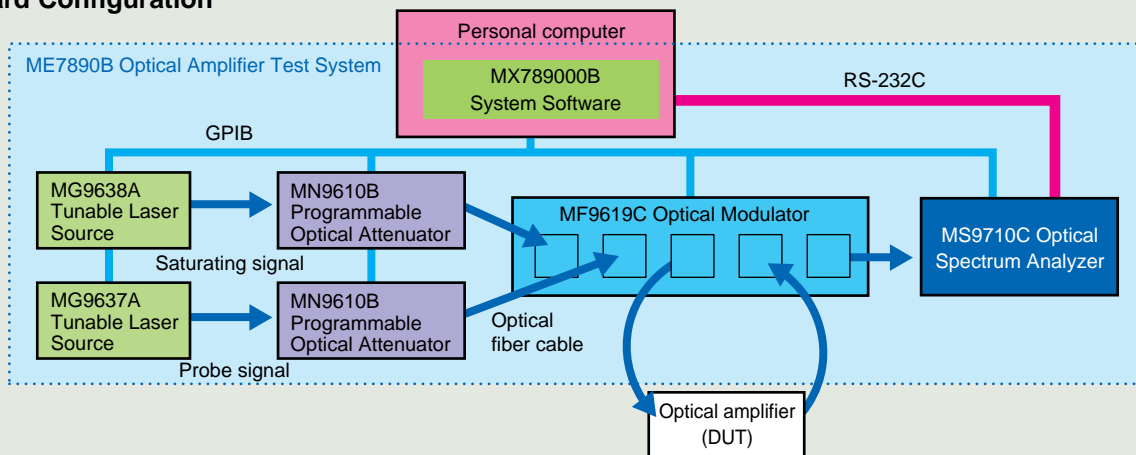

Using WDM Light Source

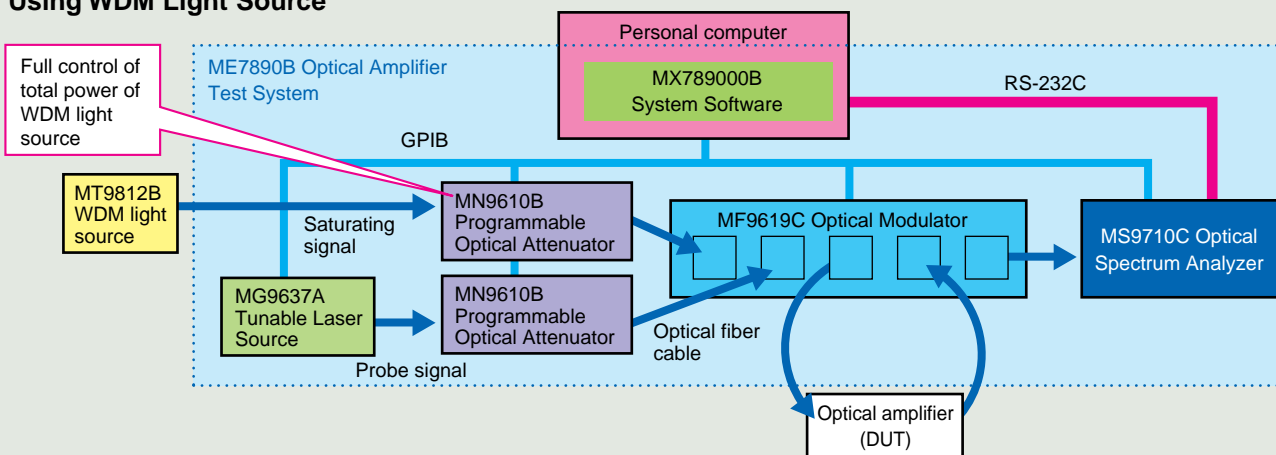

Using MS9710C SLD Light Source Output (option) as the Probe Light Signal

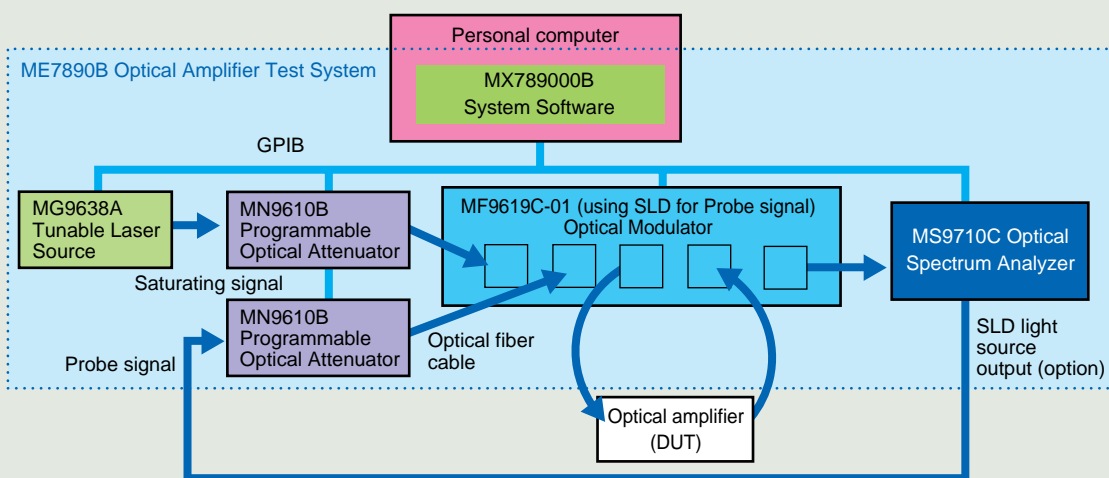

When a wide-band light source such as an SLD is used as the probe light source, specify the MF9619C (Option 01: using SLD for probe signal) with a small loss for the probe light input port. However, EDFAs saturation input level is reduced by 3 dB.

Easy Operation

Multi-Screen Results Display

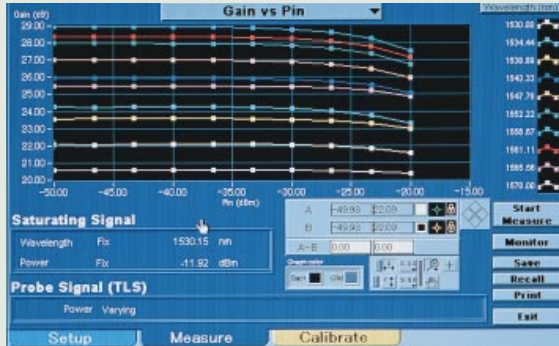

Graph Display Selection

- Gain vs Wavelength
- Spectrum
- Pass vs Wavelength
- Port vs Wavelength
- Pin vs Wavelength
- NF vs Wavelength
- Gain vs Pin
- Pass vs Pin
- Port vs Pin
- NF vs Pin

Convenient Marker Display



Supports Various Measurements

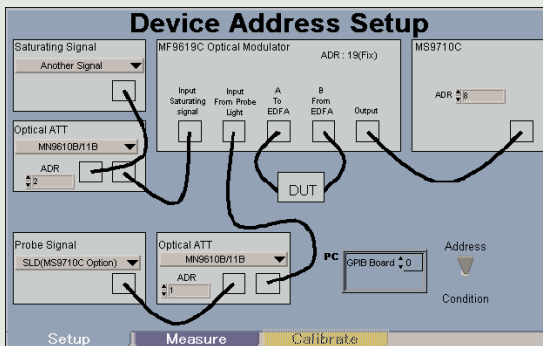

Integrated Setting of Measurement Conditions

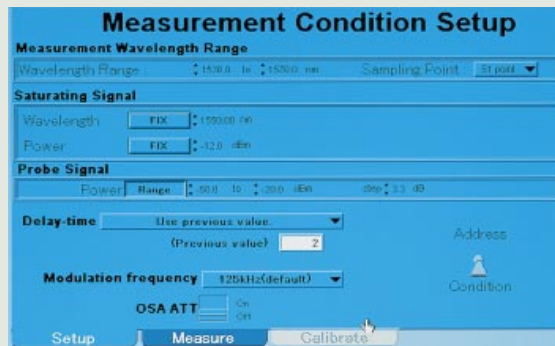

One pushing button for measurement

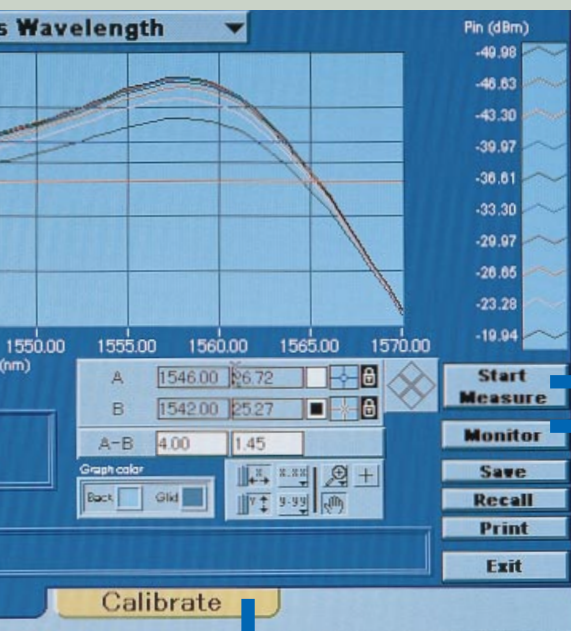

Power Monitor Function

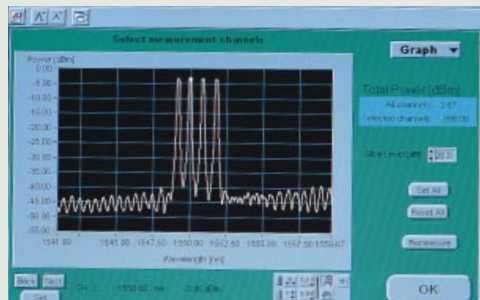

Channel selection



Real-time monitor of total, max. and min. power of selected channel to adjust the input/output power of EDFA

Display of Fiber Connection at Calibration

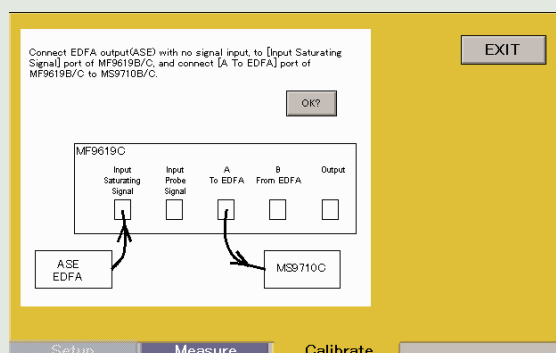

High-Accuracy Measurement by Pulse Method

High-Accuracy Measurement*1

The pulse method is the best to highly accurate measurement for NF and gain. In the pulse method, the on/off extinction ratio of the optical modulator is better than 65 dB, which causes almost no error in measuring the ASE level as a result of leakage of the amplified optical signal. In addition, the ASE level is measured directly, so there is no deviation from the actual noise gap resulting from measurement using the fitting method. The polarization dependency and the insertion loss are both optimized along with excellent reliability.

In the following diagram, the measured spectrum is expanded, and the measured ASE spectrum can be observed with almost no error.

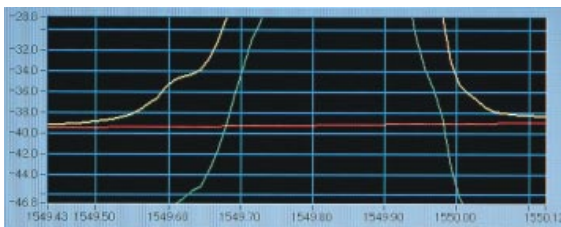

*1 Considering fiber connection/disconnection reproducibility at calibration, power meter measurement level accuracy, optical spectrum analyzer (OSA) wavelength flatness/level linearity/resolution accuracy, optical switch switching reproducibility, optical switch and OSA polarization dependency, measured wavelength accuracy. The NF accuracy is found from the following equation for the error of part and the total error is estimated by the RSS method.

$$NF = \frac{P_{ase} \times \lambda^3}{h \times c^2 \times RES \times G} + \frac{1}{G}$$

where, P_{ase} : ASE level of signal wavelengths, h : Planck's constant, RES : OSA resolution, λ : Wavelength, c : Velocity of light in a vacuum, G : Optical amplifier gain

Measurement Example

The following diagram shows a measurement example using a 16-channel WDM light source (top: spectrum display, bottom: gain and NF profile display)



System Setup

At measurement using the pulse method, the system controls the MS9710C Optical Spectrum Analyzer and the MF9619C Optical Modulator. A WDM light source can also be used. At measurement start, the wavelength of each channel is detected and the NF and gain of each channel is measured automatically.

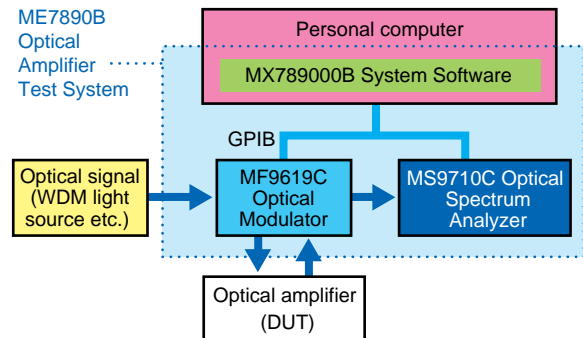

Operation Principle

The input optical signal is modulated by the optical modulator (AOM1) and input to the optical amplifier (DUT). The optical amplifier output alternates between ASE only output timing and amplifier output signal output timing. The phase of the optical modulator (AOM2) at the output side is adjusted so only the ASE is output to the optical spectrum analyzer where the power is measured.

Generally, the ASE response time of an optical amplifier is several kHz so when the modulation frequency is enough higher than this, the ASE has the same power as when the optical signal is actually being input. In this system, the optical modulator performs modulation at a high level of 125/250 kHz (default value). In addition, at gain measurement, the internal optical switch is switched automatically and the power of the optical signal at input and after amplification is measured.

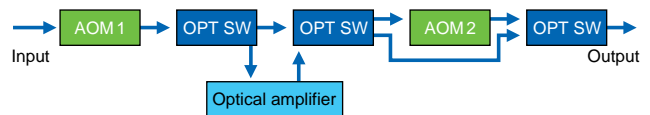

MF9619C Optical Modulator Block Diagram

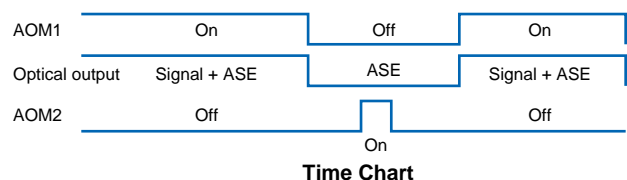

Matrix Measurement Using Tracking Function

Automatic Setting of Wavelength and Power

When the tracking function is used, the tunable laser source and programmable optical attenuator are controlled. The NF and gain are measured automatically using a matrix as the wavelength and level are varied.

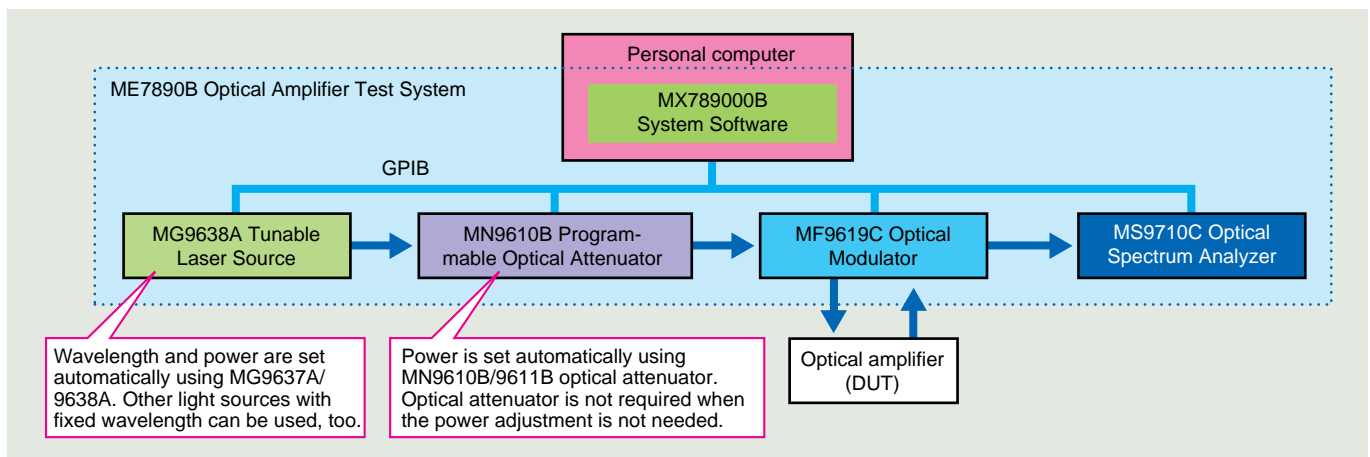
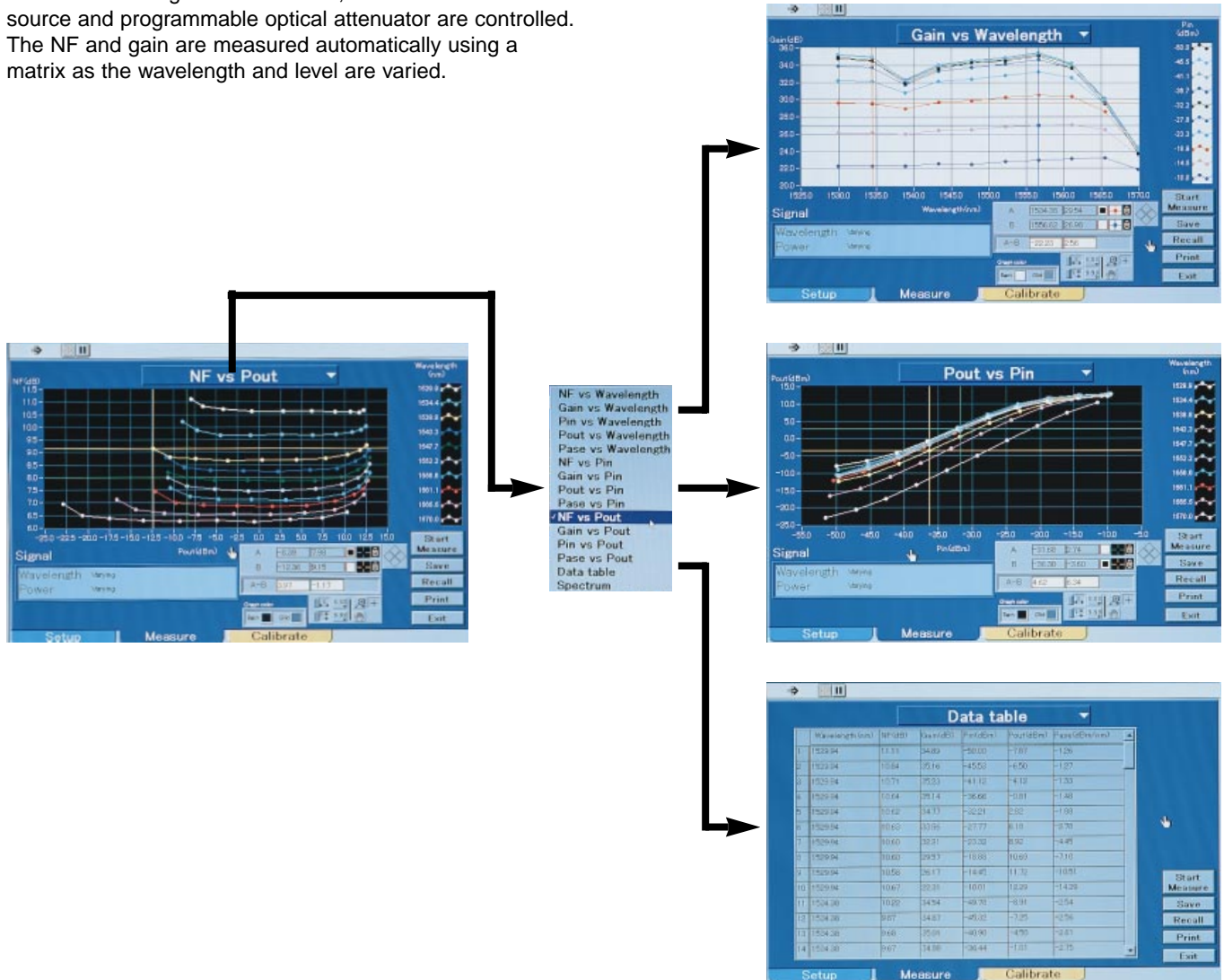

System Setup

Specifications

ME7890B Optical Amplifier Test System

To ensure that the system operates with good stability, warm it up for about 20 minutes. The following specifications were obtained after 2-hour warm-up period.

Measurement wavelength	1530 to 1620 nm (guaranteed range), 1525 to 1635 (measurable range)
Input level range	Input signal (INPUT SATURATING SIGNAL port): -40 to +10 dBm/nm (MS9710C attenuator: off), -25 to +20 dBm/nm (MS9710C attenuator: on) Input port of EDFA output (B from EDFA port): +10 dBm/nm (MS9710C attenuator: off), +23 dBm/nm (MS9710C attenuator: on)
NF measurement accuracy*1	≤0.3 dB (1530 to 1570 nm), ≤0.4 dB (1570 to 1620 nm) *After calibration, temp. change: within ±3°C, modulation frequency: 125/250 kHz, pulse measurement method
NF measurement reproducibility	≤0.2 dB *After calibration, temp. change: within ±3°C, modulation frequency: 125/250 kHz, pulse measurement method
Gain measurement accuracy	≤0.125 dB
Gain measurement reproducibility	≤0.1 dB
Measurement channel number	1 to 256 channel
Minimum channel interval	0.4 nm (50 GHz)
Functions	Calibration, data save/recall, printout
Measurement modes	Normal by WDM light source (1 to 256 channel, pulse method), matrix of level vs. wavelength by tunable laser source tracking, pulse probe
Measurement results displays	Normal mode: Spectrum (Pin, Pout, ASE), measurement result table, NF/gain profile Tunable laser source operation mode: (Wavelength, input power, output power) vs. (NF, gain, input power, output power, ASE power), spectrum, table Probe measurement mode: X axis (Wavelength, input power, saturating signal power, saturating signal wavelength) vs. Y axis (NF, gain, input power, output power, ASE power), spectrum
EMC	EN55011 (1991, Group 1, Class A), EN50082-1 (1992), Harmonic current emission EN61000-3-2 (1995)
Safety	EN61010-1 (1993, Installation Category II, Pollution Degree II)
Power	85 to 132 Vac/170 to 250 Vac, 47.5 to 63 Hz, ≤800 VA
Dimensions and mass	550 (W) × 1792 (H) × 700 (D) mm, ≤250 kg
Temperature and humidity	Temperature: 0° to 40°C (operating, MG9637A/9638A: 10° to 35°C), -20° to +60°C (storage) Humidity: ≤90% (no condensation)

*1 Using master cord (J0846B) guaranteed at calibration and measurement

The NF value is not measured directly. Since direct evaluation is not possible, the measurement error is specified for the required all items. Each error is mutually independent and the final NF error is determined by averaging the sum of squares.

The details of the NF measurement accuracy are as follows:

ASE level measurement accuracy:

±0.255 dB (including reproducibility due to fiber connection/disconnection at calibration, error after calibration of level accuracy with power meter with level accuracy of better than 2.2%, level linearity, and optical switch switching reproducibility)

Gain (I/O) measurement accuracy:

±0.125 dB (including level linearity, polarization dependency, optical switch switching reproducibility)

Wavelength resolution accuracy: ±0.1 dB (MS9710C: 1530 to 1570 nm), ±0.2 dB (MS9710C: 1570 to 1620 nm)

Measured wavelength accuracy: ±0.0001 dB (MS9710C)

MF9619C Optical Modulator

Insertion loss (25°C)	Saturating signal: ≤10 dB (1530 to 1630 nm), ≤9.5 dB (1530 to 1630 nm, Option 02) *Between [INPUT SATURATION SIGNAL] and [A to EDFA] ports Probe signal: ≤14 dB (1530 to 1630 nm) *Between [INPUT PROBE SIGNAL] and [A to EDFA] ports
Modulation extinction ratio	≥65 dB (25°C, at 125/250 kHz modulation)
EMC	EN55011 (1991, Group 1, Class A), EN50082-1 (1992), Harmonic current emission EN61000-3-2 (1995)
Safety	EN61010-1 (1993, Installation Category II, Pollution Degree II)
Power supply	85 to 132 Vac/170 to 250 Vac, 47.5 to 63 Hz, ≤100 VA
Dimensions and mass	320 (W) × 132.5 (H) × 350 (D) mm, ≤8 kg
Temperature and humidity	Temperature: 0° to 40°C (operating); -20° to +60°C (storage) Humidity: ≤90% (no condensation)

Recommended Controller

Hardware	PC-AT compatible computer running Windows® 3.1/95/98*2
CPU, memory, display, OS	Pentium 75 MHz or faster, ≥16 MB (≥32 MB recommended), 640 × 480 or better resolution, Microsoft® Windows® operating system Version 3.1, Windows 95 operating system, or Windows 98 operating system
Memory drives	HDD with at least 20 MB free space, 3.5" FDD (2 HD, 1.44 MB)
GPIB, RS-232C	National Instruments product, one port (when using MG9637A/9638A as probe light source)

*2 Microsoft® Windows® operating system Version 3.1, Microsoft® Windows® 95 operating system, or Microsoft® Windows® 98 operating system are registered trademarks of Microsoft Corporation (USA).

●Refer to the relevant manuals for the specifications of the equipment listed below.

MS9710C Optical Spectrum Analyzer, MG9637A/9638A Tunable Laser Source, MN9610B/9611B Programmable Optical Attenuator

Ordering Information

Specify the model/order number, name, and quantity when ordering.

Model/Order No.	Name	Remarks	Model/Order No.	Name	Remarks
ME7890B	System Optical Amplifier Test System		J0692B	FC•PC-SC•PC-2M-SM	
MG9637A	Tunable Laser Source*2: 1 set	For probe signal	J0763B	FC•PC-HMS-10/A•PC-2M-SM	
MG9638A	Tunable Laser Source*3: 1 set	For saturating signal	J0617B	Replaceable optical connector (FC)	
MN9610B	Programmable Optical Attenuator*4: 2 sets		J0618D	Replaceable optical connector (ST)	
MF9619C	Optical Modulator: 1 set	Includes MX789000B Software for Optical Amplifier Test System Control	J0618E	Replaceable optical connector (DIN)	
MS9710C	Optical Spectrum Analyzer: 1 set		J0618F	Replaceable optical connector (HMS-10/A)	
B0422A	System rack: 1 pc	For 100 V system	J0619B	Replaceable optical connector (SC)	
B0423B	Rack mount kit: 2 pc	For MG9637A/9638A	Z0282	Ferrule cleaner	
B0390F	Rack mount kit: 1 pc	For two MN9610Bs	Z0283	Tape for Ferrule cleaner (6 pcs/set)	
B0424A	Rack mount kit: 1 pc	For MF9619C	Z0284	Adapter cleaner (200 pcs/set)	
B0423A	Rack mount kit: 1 pc	For MS9710C	J0655A	RS-232C cable (9P-2P)	
W1697AE	Standard accessories ME7890B/MF9619C operation manual: 1 copy		B0422B	System rack	For 200 V system (C7 plug)
J0654A	Application parts RS-232C cable (9P-9P)*5		B0422C	System rack	For 200 V system (B4 plug)
J0007	GPIB cable, 1 m*5		J0390E	Rack mount kit	For 1 MN9610B
J0008	GPIB cable, 2 m*5		MF9619C	Main frame Optical Modulator	
J0846B	FC•PC(MASTER)-FC•PC-2M-SM*6		J0017	Power cord, 2.5 m: 1 pc	
J0057	FC adapter*6		F0012	Fuses, 3.15 A: 2 pcs	For 100 V system
J0847A	FC-ST conversion adapter		F0010	Fuses, 1.6 A: 2 pcs	For 200 V system
J0848A	FC-DIN conversion adapter		B0329F	Front cover: 1 pc	3/4MW 4U
J0849B	FC-SC conversion adapter		MX789000B	Software for Optical Amplifier Test System Controller: 1 set	For Windows 3.1/95/98
J0850A	FC-HMS-10/A conversion adapter		MF9619C-01	Options Using SLD for probe signal	
J0635B	FC•PC-FC•PC-2M-SM		MF9619C-38	ST connector	
J0757B	FC•PC-ST•PC-2M-SM		MF9619C-39	DIN connector	
J0760B	FC•PC-DIN•PC-2M-SM		MF9619C-40	SC connector	
			MF9619C-43	HMS-10/A connector	
			B0424A	Application parts Rack mount kit	For MF9619C

*1 Only the required instruments can be selected and ordered from the standard configuration.

*2 The MG9638A Tunable Laser Source can also be used.

*3 The MG9637A Tunable Laser Source can also be used.

*4 The MN9611B Programmable Optical Attenuator can also be used.

*5 The full system (standard) requires five 1 m GPIB cables, one 2 m GPIB cable, and one RS-232C cable.

The RS-232C cable is required when using a tunable light source as the probe light source.

Consult Anritsu for the number required by the system setup.

*6 When measuring NF with an accuracy of ± 0.3 dB, six master cords (J0846B) and five adapters are required.

Note: For personal computer, please contact your nearest Anritsu representative.



Specifications are subject to change without notice.

ANRITSU CORPORATION

5-10-27, Minamiazabu, Minato-ku, Tokyo 106-8570, Japan
Phone: +81-3-3446-1111
Telex: J34372
Fax: +81-3-3442-0235

Overseas Subsidiaries

● U.S.A.

ANRITSU COMPANY

North American Region Headquarters

1155 East Collins Blvd., Richardson, Tx 75081, U.S.A.
Toll Free: 1-800-ANRITSU (267-4878)
Phone: +1-972-644-1777
Fax: +1-972-671-1877

● Canada

ANRITSU ELECTRONICS LTD.

Unit 102, 215 Stafford Road West
Nepean, Ontario K2H 9C1, Canada
Phone: +1-613-828-4090
Fax: +1-613-828-5400

● Brasil

ANRITSU ELETRÔNICA LTDA.

Praia de Botafogo 440, Sala 2401 CEP 22250-040,
Rio de Janeiro, RJ, Brasil
Phone: +55-21-5276922
Fax: +55-21-537-1456

● U.K.

ANRITSU LTD.

200 Capability Green, Luton, Bedfordshire LU1 3LU, U.K.
Phone: +44-1582-433200
Fax: +44-1582-731303

● Germany

ANRITSU GmbH

Grafenberger Allee 54-56, 40237 Düsseldorf, Germany
Phone: +49-211-96855-0
Fax: +49-211-96855-55

● France

ANRITSU S.A.

9, Avenue du Québec Z.A. de Courtabœuf 91951 Les
Ulis Cedex, France
Phone: +33-1-60-92-15-50
Fax: +33-1-64-46-10-65

● Italy

ANRITSU S.p.A.

Via Elio Vittorini, 129, 00144 Roma EUR, Italy
Phone: +39-06-509-9711
Fax: +39-06-502-24-25

● Sweden

ANRITSU AB

Botvid Center, Fittja Backe 1-3 145 84 Stockholm,
Sweden
Phone: +46-853470700
Fax: +46-853470730

● Singapore

ANRITSU PTE LTD.

6, New Industrial Rd., #06-01/02, Hoe Huat Industrial
Building, Singapore 536199
Phone: +65-282-2400
Fax: +65-282-2533

● Hong Kong

ANRITSU COMPANY LTD.

Suite 719, 7/F., Chinachem Golden Plaza, 77 Mody
Road, Tsimshatsui East, Kowloon, Hong Kong, China
Phone: +852-2301-4980
Fax: +852-2301-3545

● Korea

ANRITSU CORPORATION

14F Hyun Juk Bldg, 832-41, Yeoksam-dong,
Kangnam-ku, Seoul, Korea
Phone: +82-2-553-6603
Fax: +82-2-553-6604~5

● Australia

ANRITSU PTY LTD.

Unit 3/170 Forster Road Mt. Waverley, Victoria, 3149,
Australia
Phone: +61-3-9558-8177
Fax: +61-3-9558-8255

● Taiwan

ANRITSU COMPANY INC.

6F, 96, Sec. 3, Chien Kou North Rd. Taipei, Taiwan,
R.O.C.
Phone: +886-2-2515-6050
Fax: +886-2-2509-5519



Artisan Scientific

QUALITY INSTRUMENTATION ... GUARANTEED

Looking for more information?

Visit us on the web at <http://www.artisan-scientific.com> for more information:

- Price Quotations
- Drivers
- Technical Specifications, Manuals and Documentation

Artisan Scientific is Your Source for Quality New and Certified-Used/Pre-owned Equipment

- Tens of Thousands of In-Stock Items
- Hundreds of Manufacturers Supported
- Fast Shipping and Delivery
- Leasing / Monthly Rentals
- Equipment Demos
- Consignment

Service Center Repairs

Experienced Engineers and Technicians on staff in our State-of-the-art Full-Service In-House Service Center Facility

InstraView™ Remote Inspection

Remotely inspect equipment before purchasing with our Innovative InstraView™ website at <http://www.instraview.com>

We buy used equipment! We also offer credit for Buy-Backs and Trade-Ins

Sell your excess, underutilized, and idle used equipment. Contact one of our Customer Service Representatives today!

Talk to a live person: 888-88-SOURCE (888-887-6872) | Contact us by email: sales@artisan-scientific.com | Visit our website: <http://www.artisan-scientific.com>