



Artisan Scientific

QUALITY INSTRUMENTATION ... GUARANTEED

Looking for more information?

Visit us on the web at <http://www.artisan-scientific.com> for more information:

- Price Quotations
- Drivers
- Technical Specifications, Manuals and Documentation

Artisan Scientific is Your Source for Quality New and Certified-Used/Pre-owned Equipment

- Tens of Thousands of In-Stock Items
- Hundreds of Manufacturers Supported
- Fast Shipping and Delivery
- Leasing / Monthly Rentals
- Equipment Demos
- Consignment

Service Center Repairs

Experienced Engineers and Technicians on staff in our State-of-the-art Full-Service In-House Service Center Facility

InstraView™ Remote Inspection

Remotely inspect equipment before purchasing with our Innovative InstraView™ website at <http://www.instraview.com>

We buy used equipment! We also offer credit for Buy-Backs and Trade-Ins

Sell your excess, underutilized, and idle used equipment. Contact one of our Customer Service Representatives today!

Talk to a live person: 888-88-SOURCE (888-887-6872) | Contact us by email: sales@artisan-scientific.com | Visit our website: <http://www.artisan-scientific.com>

ME7890B/MF9619C
Optical Amplifier Test System/Optical Modulator
Operation Manual

First Edition

Read this manual before using the equipment.
Keep this manual with the equipment.

Measuring Instruments Division
Measurement Group
ANRITSU CORPORATION

Document No.: M-W1697AE-1.0

Safety Symbols

To prevent the risk of personal injury or loss related to equipment malfunction, Anritsu Corporation uses the following safety symbols to indicate safety-related information. Insure that you clearly understand the meanings of the symbols BEFORE using the equipment.

Some or all of the following symbols may not be used on this equipment. In addition, when drawings are included in this manual, labels on the equipment may not be shown on them.

Symbols Used in Manual

DANGER



This indicates a very dangerous procedure that could result in death or serious injury if not performed properly.

WARNING



This indicates a hazardous procedure that could result in death or serious injury if not performed properly.

CAUTION



This indicates a hazardous procedure or danger that could result in light-to-severe injury, or loss related to equipment malfunction, if proper precautions are not taken.

Safety Symbols Used on Equipment and/or in Manual

The following safety symbols are used inside or on the equipment near operation locations, and/or in manual to provide information about safety items and operation precautions. Insure that you clearly understand the meanings of the symbols and take the necessary precautions BEFORE using the equipment.



This indicates a prohibited operation. The prohibited operation is indicated symbolically in or near the barred circle.



This indicates an obligatory safety precaution. The obligatory operation is indicated symbolically in or near the circle.



This indicates warning or caution. The contents are indicated symbolically in or near the triangle.



This indicates a note. The contents are described in the box.



These indicate that the marked part should be recycled.

ME7890B/MF9619C

Optical Amplifier Test System/Optical Modulator

Operation Manual

21 December 1999 (First Edition)

Copyright © 1999, ANRITSU CORPORATION.

All rights reserved. No part of this manual may be reproduced without the prior written permission of the publisher.

The contents of this manual may be changed without prior notice.

Printed in Japan

ERRATA

Rev. 1.1 (1/1)

ME7890B/MF9619C Operation Manual

The following revisions were made after the first edition of the ME7890B/MF9619C Operation Manual was issued. Please read the column on the right for the changes to the items in the column on the left.

PAGE /SECTION	WRONG	RIGHT
P.1-7 /1.5.2	F0012/F0010: Fuse, 3.15A (100 V system) /1.6A (200 V system)	F0012: Fuse, 3.15A

WARNING



Repair

WARNING 

Falling Over

- 1 ALWAYS refer to the operation manual when working near locations at which the alert mark shown on the left is attached. If the operation, etc., is performed without heeding the advice in the operation manual, there is a risk of personal injury. In addition, the system performance may be reduced.
Moreover, this alert mark is sometimes used with other marks and descriptions indicating other dangers.
- 2 When supplying power to this system and each the equipment, connect each the 3-pin power cord (the accessories of this system and each the equipment) to a 3-pin grounded power outlet for grounding this system and each the equipment. If a grounded 3-pin outlet is not available, before supplying power to this system and each the equipment, use a conversion adapter and ground the green wire, or connect the frame ground terminal on the rear panel of the system rack or the rear panel of the equipment to ground. If power is supplied without grounding this system and each the equipment, there is a risk of receiving a severe or fatal electric shock.
- 3 This system and each the equipment cannot be repaired by the user. DO NOT attempt to open the cabinet or to disassemble internal parts. Only Anritsu-trained service personnel or staff from your sales representative with a knowledge of electrical fire and shock hazards should service this equipment. There are high-voltage parts in this system and each the equipment presenting a risk of severe injury or fatal electric shock to untrained personnel. In addition, there is a risk of damage to precision parts.
- 4 This system and each the equipment should be used in the correct position. If the system rack or the equipment is turned on its side, etc. when not used; it will be unstable and may be damaged if it falls over as a result of receiving a slight mechanical shock.

WARNING 

-
- 5 The display part of the MG9637A/MG9638A Tunable Laser Source in this system uses a Liquid Crystal Display (LCD); DO NOT subject the instrument to excessive force or drop it. If the LCD is subjected to strong mechanical shock, it may break and liquid may leak.

This liquid is very caustic and poisonous.

LCD

DO NOT touch it, ingest it, or get in your eyes. If it is ingested accidentally, spit it out immediately, rinse your mouth with water and seek medical help. If it enters your eyes accidentally, do not rub your eyes, irrigate them with clean running water and seek medical help. If the liquid gets on your skin or clothes, wash it off carefully and thoroughly.

CAUTION

- 1 Before changing the fuses of each the equipment, ALWAYS remove the power cord from the power outlet and replace the blown fuses with the those described in this manual. Or, use new fuses of the type and rating specified on the fuse marking on the rear panel of each the equipment.

For the fuse label,

___T indicates a time-lag fuse.

___A or F__A indicate a normal fusing type fuse.

There is risk of receiving a fatal electric shock if the fuses are replaced with the power cord connected.

- 2 Keep this system's and each the equipment's power supply and cooling fan free of dust.
 - Clean the power inlet regularly. If dust accumulates around the power pins, there is a risk of fire.
 - Keep the cooling fan clean so that the ventilation holes are not obstructed. If the ventilation is obstructed, the cabinet may over- heat and catch fire.

Changing Fuse

CAUTION 

Cleaning

LASER SAFETY

The laser light emitted from the MG9637A/MG9638A Tunable Laser Source in this system meets Class 1 of the related standards (JIS, IEC825, and 21CFR1040.10) that indicates safe laser presenting no danger when used according to design specifications.

The "Class 1 or (Class 1)" is indicated at the _ _ _ _ _ on the MG9637A/MG9638A Tunable Laser Source in this system.

WARNING 

Laser Radiation Markings

The MG9637A/MG9638A Tunable Laser Sources in this system have a Class 3 laser light emitting device.

The MG9637A/MG9638A in this system meet the danger classification of the JIS/IEC825/21CFR1040.10 standards, as shown below:

	MG9637A	MG9638A
IEC825	Class 3A	Class 3A
21CFR1040.10	Class 1	Class 1

Class 1, Class 2 and Class 3 indicates the degree of danger of the laser radiation outlined below as defined by JIS, IEC825 and 21CFR1040.10.

Class 1: Safe laser presenting no danger when used according to design specifications.

Class 2: Laser radiating in 400 to 700 nm wavelength range. In principal, this calss of laser is not safe, but the danger to the eyes is eliminated by the eye avoidance reaction including the blink response.

Class 3A: Laser radiating in 400 to 700 nm wavelength range. The danger to the eyes is eliminated by the eye avoidance reaction including the blink response. For lasers radiating at other wavelengths, the degree of danger to the naked eyes is not greater than Class 1.

Class 3B: The eyes will be damaged if direct laser radiation enters the eyes. Normally there is no danger if the diffused beam is observed.

Equipment Certificate

Anritsu Corporation certifies that this equipment was tested before shipment using calibrated measuring instruments with direct traceability to public testing organizations recognized by national research laboratories including the Electrotechnical Laboratory, the National Research Laboratory of Metrology and the Communications Research Laboratory, and was found to meet the published specifications.

Anritsu Warranty

Anritsu Corporation will repair this equipment free-of-charge if a malfunction occurs within 1 year after shipment due to a manufacturing fault, provided that this warranty is rendered void under any or all of the following conditions.

- The fault is outside the scope of the warranty conditions described in the operation manual.
- The fault is due to mishandling, misuse, or unauthorized modification or repair of the equipment by the customer.
- The fault is due to severe usage clearly exceeding normal usage.
- The fault is due to improper or insufficient maintenance by the customer.
- The fault is due to natural disaster including fire, flooding, earthquake, etc.
- The fault is due to use of non-specified peripheral equipment, peripheral parts, consumables, etc.
- The fault is due to use of a non-specified power supply or in a non-specified installation location.

In addition, this warranty is valid only for the original equipment purchaser. It is not transferable if the equipment is resold.

Anritsu Corporation will not accept liability for equipment faults due to unforeseen and unusual circumstances, nor for faults due to mishandling by the customer.

Anritsu Corporation Contact

If this equipment develops a fault, contact Anritsu Corporation or its representatives at the address in this manual.

Trade Marks

MS-DOS® and Windows® are the registered trademarks of the Microsoft Corporation US in US and other countries.

NI-488.2® and LabVIEW® are the registered trademarks of the National Instrument Corporation in US and other countries.

Software License Agreement

Please read this Software License Agreement before using the accompanying software program (hereafter this software).

You are authorized to use this software only if you agree to all the terms of this License.

By opening the sealed package containing this software, you are agreeing to be bound by the terms of this License. If you do not agree to these terms, return the unopened software package to Anritsu Corporation (hereafter Anritsu).

1. License

- (1) This License gives you the right to use this software on one ME7890B/MF9619C (hereafter computer system).
- (2) To use this software on one computer system, this License allows you to make one copy of this software on the storage device of your computer system.
- (3) You must obtain a site license to use this software on more than one computer system even if such computer systems are not operating simultaneously.

2. Copyright

- (1) Although you are licensed to use this software, Anritsu retains the copyright.
- (2) Although you have purchased this software, rights other than those specified in this License are not transferred to you.
- (3) You may not print, copy, modify, create derivative works, incorporate in other software programs, decompile or disassemble this software in whole or in part, without obtaining prior written permission from Anritsu.

3. Copying

Notwithstanding item (3) of section 2 above, you may make one copy of this software for backup purposes only. In this case, you may only use either the backup copy or the original copy of this software.

4. Termination

- (1) Anritsu will deem this License to be automatically terminated if you fail to comply with any provision of this License. Upon termination, you will lose all rights to this software.
- (2) Either party (Anritsu or yourself) to this Software License Agreement may terminate this Agreement by giving 1 months notice in writing to the other party.
- (3) Upon termination of this License for any reason, you must either immediately destroy this software and related documentation, or return it to Anritsu.

CE Marking

Anritsu affix the CE Conformity Marking on the following product (s) accordance with the Council Directive 93/68/EEC to indicate that they conform with the EMC directive of the European Union (EU).

CE Conformity Marking

1. Product Name / Model Name

Product Name : Optical Amplifier Test System/Optical Modulator

Model Name : ME7890A/MF9619B

2. Applied Directive

EMC : Council Directive 89/336/EEC

Safety : Council Directive 73/23/EEC

3. Applied Standards

EMC :

Electromagnetic radiation :

EN55011 (ISM, Group 1, Class A equipment)

Immunity : EN50082-1

Performance criteria*

IEC801-2 (ESD)	4k VCD, 8k VAD	B
IEC801-3 (Rad.)	3V/m	A
IEC801-4 (EFT)	1kV	B

*: Performance criteria

A : No performance degradation or function loss

B : Self-recovered temporary degradation of performance or temporary loss of function

Harmonic Current emissions :

EN61000-3-2 (Class A equipment)

Safety : EN61010-1 (Installation Category II, Pollution Degree 2)

Introduction

The ME7890B optical amplifier test system comes standard with the following units.

- MG9637A tunable laser source 1
- MG9638A tunable laser source 1
- MN9610B programmable optical attenuator 2
- MF9619C optical modulator 1
(including MX789000B, a set of software for controlling the optical amplifier test system)
- MS9710C optical spectrum analyzer 1
- B0422A system rack 1
- B0423B rack mount kit 2
- B0390F rack mount kit 1
- B0424A rack mount kit 1
- B0423A rack mount kit 1

This document describes the operation, calibration, and maintenance methods of the entire system, MF9619C, and MX789000B.

Before using this system, read the operation manual of the MG9637A/MG9638A tunable laser source (M-W1213AE), the operation manual of the MN9610B/MN9611B programmable optical attenuator, and the operation manual of the MS9710C optical spectrum analyzer.

 indicates the section number containing related descriptions.

Contents

Safety Symbols.....	ii
For Safety	iii
Introduction	I
Section 1 General	1-1
1.1 ME7890B Optical Amplifier Test System.....	1-2
1.2 Main Functions	1-3
1.3 Features	1-4
1.4 Functions of ME7890B	1-5
1.5 Standard Composition	1-6
1.6 Specifications	1-8
1.7 Switching the Screens.....	1-11
Section 2 External Components and Their Functions.....	2-1
2.1 Unpacking.....	2-2
2.2 External Components and their Functions.....	2-3
Section 3 Before Using This System.....	3-1
3.1 Grounding Conditions.....	3-2
3.2 Grounding.....	3-4
3.3 Cautions on Vibration and Shock	3-5
3.4 Laser Safety	3-6
3.5 Connecting an Optical Fiber Cable.....	3-7
3.6 Replacing an Optical Connector.....	3-8
3.7 Replacing a Fuse.....	3-9
Section 4 Setting Up The System	4-1
4.1 Operating Environment.....	4-2
4.2 Installing Software	4-3
4.3 Setting Up Devices	4-4
4.4 Starting/Exiting the Program.....	4-5

Section 5	Measurement Mode	5-1
5.1	General	5-2
5.2	Normal Mode (Pulse Method)	5-3
5.3	Tunable Laser Source Interlock Measurement Mode (Pulse Method).....	5-4
5.4	Optical Pulse Probe Method Measurement Mode	5-5
Section 6	Normal Measurement Mode.....	6-1
6.1	Setup.....	6-2
6.2	Measurement	6-3
6.3	Displaying Measured Results.....	6-6
6.4	Printing.....	6-8
6.5	Saving and Recalling Measured Results.....	6-9
6.6	Power Monitor Function	6-10
6.7	Selecting Data Clear	6-11
Section 7	Tunable Laser Source Interlock Measurement Mode	7-1
7.1	Setup.....	7-2
7.2	Measurement	7-7
7.3	Displaying Measured Results.....	7-9
7.4	Printing.....	7-11
7.5	Saving and Recalling Measured Results.....	7-12
Section 8	Probe Method Measurement Mode	8-1
8.1	Setup.....	8-2
8.2	Measurement	8-9
8.3	Displaying Measured Results.....	8-13
8.4	Power Monitor.....	8-16
8.5	Printing.....	8-19
8.6	Saving and Recalling Measurements.....	8-20
8.7	Adjusting Probe Optical Power.....	8-21
8.8	Determining Saturating Signal Light.....	8-23
Section 9	Calibration.....	9-1
9.1	Calibration.....	9-2
9.2	Checking Calibration Data.....	9-6

1
2
3
4
5
6
7
8
9
10
11
12
13
14

Section 10 To Make Highly Accurate	
Measurement	10-1
10.1 Error Factors.....	10-2
10.2 Level Accuracy Correction of Optical Spectrum Analyzer	10-6
10.3 System Calibration	10-7
 Section 11 Manipulating Graphs	 11-1
11.1 Scaling Up and Down	11-2
11.2 Movement.....	11-3
11.3 Changing Axis Labels	11-4
11.4 Changing Background and Grid Colors.....	11-5
11.5 Cursor.....	11-6
11.6 Plot Style	11-8
 Section 12 Maintenance and	
Re-transportation.....	12-1
12.1 Daily Maintenance	12-2
12.2 Cautions on Storage	12-6
12.3 Re-transportation.....	12-7
12.4 Before Calling Maintenance Persons	12-8
 Section 13 Performance Check and	
Calibration	13-1
13.1 Performance Check.....	13-2
13.2 Calibration	13-2
 Section 14 Appendix	 14-1
14.1 Principle of Operation	14-2
14.2 Measurement Power	14-5
14.3 Delay Time	14-6
14.4 Modulation Frequency	14-7
14.5 Measurement Time.....	14-8
14.6 Optical Surge.....	14-9
14.7 Data Saving Format.....	14-10
14.8 Changing Wavelength Range.....	14-13
14.9 Reading Data without Measuring Instruments	14-14
14.10 Performance Test Result List	14-15

IV.

This section describes the outline of the ME7890B optical amplifier test system and its peripheral devices.

1.1	ME7890B Optical Amplifier Test System	1-2
1.2	Main Functions.....	1-3
1.3	Features	1-4
1.4	Functions of ME7890B.....	1-5
1.4.1	TLS interlock	
	measurement function	1-5
1.4.2	Probe method	1-5
1.5	Standard Composition.....	1-6
1.5.1	ME7890B Optical Amplifier	
	Test System	1-6
1.5.2	MF9619C Optical Modulator	1-7
1.5.3	Other Composition Units.....	1-7
1.6	Specifications	1-8
1.6.1	ME7890B Optical Amplifier	
	Test System Specifications	1-8
1.6.2	MF9619C Optical Modulator	
	Specifications.....	1-10
1.6.3	Recommended Controllers	1-10
1.7	Switching the Screens.....	1-11
1.7.1	Normal Mode	1-12
1.7.2	TLS interlock Mode	1-13
1.7.3	Probe Method Mode	1-14

1.1 ME7890B Optical Amplifier Test System

The ME7890B is an optical amplifier test system that measures NF (noise figure)/Gain accurately in the pulse method as well as the wavelength characteristics of NF/Gain in the probe method. In the probe method, the wavelength characteristics are measured using weak light (probe light) that does not affect the population inversion state of the optical amplifier by using one or several saturating signal lights that generate the saturating state equivalent to the WDM light source used to test the optical amplifier.

Previous measurements could be performed only in the wavelength range of band C (1530-1570 nm). However, with this system, measurements can be performed in band L (1570-1620 nm) and band C.

This system mainly consists of the MS9710C optical spectrum analyzer, MF9619C optical modulator (including MX789000B, a set of software for controlling the optical amplifier test system), the MG9637A/MG9638A tunable laser source, and the MN9610B/MN9611B programmable optical attenuator. Besides this system, a personal computer for controlling the entire system in order to make measurement is required.

1.2 Main Functions

1

The functions in this system include the normal mode and TLS interlock mode using the pulse method, as well as the probe method mode using the probe method.

In the normal mode, the NF and Gain of the optical amplifier can be measured in the wavelength range between 1530 nm and 1620 nm. The signals with wavelength division multiplex can be measured collectively.

In the TLS interlock mode, the wavelength characteristics of the NF and Gain can be measured by changing the wavelength input to the optical amplifier and the optical power using a tunable laser source and a programmable optical attenuator.

In the probe method mode, the wavelength characteristics can be measured in the saturating state equivalent to the state using the WDM signal by making the probe method measurement. As probe light, either the tunable laser source (TLS) or the wide-band laser source can be selected. If the tunable laser source is used, highly accurate measurement can be made. If the broad-band laser source is used, the slope of the wavelength characteristics of NF/Gain can be measured in a short time.

With the input light power monitor function, the level of the optical power input to the optical amplifier can be adjusted easily.

The measured results can also be output to the printer. Since the data can be saved in text format, it is possible to read the measured result into a commercially available spread sheet software product and analyze it.

1.3 Features

The features of this system are shown below.

- (1) Since ASE (amplified spontaneous emission) power is measured directly, there is no error between the actual noise curve and the measurement made in the fitting method.
- (2) Since the on/off extinction ratio (65 dB or more) of the MF9619C optical modulator is sufficiently held, the ASE power measurement error due to the leak of amplified light is not generated.

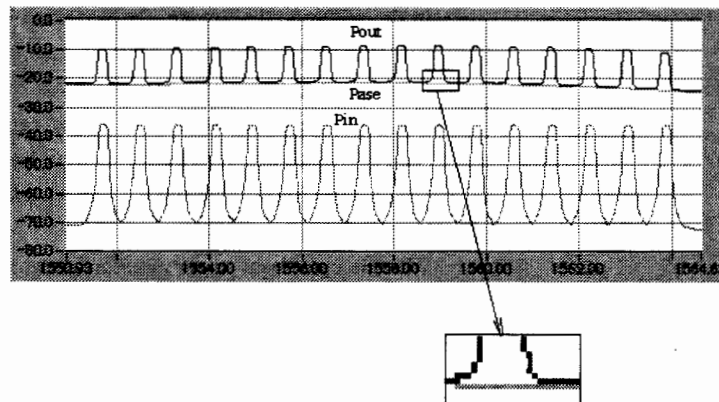

Pin : Input light spectrum

Pout : Amplified light spectrum

Pase : ASE spectrum

- (3) Since modulation is performed in sufficiently high modulation frequency (125/250 kHz) compared to the response of ASE, the amplified ASE power can be measured accurately.
- (4) Since the polarization-dependent characteristics and insertion loss are optimized, reliable data can be obtained.
- (5) Calibration of this system is very easy and all measurements are made automatically.

1.4 Functions of ME7890B

1

The measurement functions of the Optical Amplifier Test System ME7890B are as follows.

- (1) TLS interlock
- (2) Probe method

1.4.1 TLS interlock Measurement Function

The TLS interlock is the function of enabling matrix measurement by tuning the input wavelength and the input level to its device under test, the optical amplifier, using the MG9637A/MG9638A tunable laser source and MN9610B/MN9611B programmable optical attenuator.

 5.3 Tunable Laser Source Interlock Measurement Mode (Pulse Method)

1.4.2 Probe Method

The probe method is a function of measuring the wavelength characteristics in the saturating state equivalent to the WDM signal in the probe method measurement. As probe light, either the tunable laser source (TLS) or the broad-band laser source can be selected. If the tunable laser source is used, highly accurate measurement can be made. If the broad-band laser source is used, the slope of the wavelength characteristics of NF/Gain can be measured in a short time.

 5.4 Optical Pulse Probe Method Measurement Mode (Pulse Method)

1.5 Standard Composition

1.5.1 ME7890B Optical Amplifier Test System

-Standard devices-

MG9637A	:	Tunable laser source	1
MG9638A	:	Tunable laser source	1
MN9610B	:	Programmable optical attenuator	2
MF9619C	:	Optical modulator	1
		(including MX789000B: a set of software for controlling the optical amplifier test system. 5 FDs for Windows 95 and 5 FDs for Windows 3.1, total is 10 FDs.)	
MS9710C	:	Optical spectrum analyzer	1
B0422A	:	System rack	1 (for 100 V system: A2 plug type)
B0423B	:	Rack mount kit (for MG9637A/MG9638A)	2
B0390F	:	Rack mount kit	
		(for MN9610B/MN9611B for using two devices in parallel)	1
B0424A	:	Rack mount kit (for MF9619C)	1
B0423A	:	Rack mount kit (for MS9710C)	1

-Standard accessory-

W1697AW	:	ME7890B/MF9619C Optical Amplifier Test System/Optical Modulator Operation Manual	
---------	---	--	--

-Application parts-

J0007	:	GPIB cable, (1 m)	
J0008	:	GPIB cable, (2 m)	
J0654A	:	RS-232C cable, (9P-9P)	
J0655A	:	RS-232C cable, (9P-25P)	
J0846B	:	FC(PC (MASTER))-FC(PC-2M-SM)	
J0057	:	FC adapter	
J0847A	:	FC-ST type conversion adapter	
J0848A	:	FC-DIN type conversion adapter	
J0849B	:	FC-SC type conversion adapter	
J0850A	:	FC-HMS-10/A type conversion adapter	
J0635B	:	FC•PC-FC•PC-2M-SM	
J0757B	:	FC•PC-ST•PC-2M-SM	
J0760B	:	FC•PC-DIN•PC-2M-SM	
J0692B	:	FC•PC-SC•PC-2M-SM	
J0763B	:	FC•PC-HMS-10/A•PC-2M-SM	
J0617B	:	Replaceable optical connector (FC)	
J0618D	:	Replaceable optical connector (ST)	
J0618E	:	Replaceable optical connector (DIN)	
J0619B	:	Replaceable optical connector (SC)	
J0618F	:	Replaceable optical connector (HMS-10/A)	
Z0282	:	Ferrule cleaner	

Z0283	: Replacement reel for ferrule cleaner
Z0284	: Cleaner for optical adapter
B0390E	: Rack mount kit (MN9610/MN9611B for one device)
B0422B	: System rack (for 200 V system: C7 plug type)
B0422C	: System rack (for 200 V system: B4 plug type)

1.5.2 MF9619C Optical Modulator

-Standard accessories-

J0017	: Power cord, 2.5 m
F0012/F0010	: Fuse, 3.15A (100 V system)/1.6A (200 V system)
B0329F	: Front cover 3/4MW 3U
MX789000B	: Software for controlling the optical amplifier test system

-Option-

MF9619C-01	: SDL conforming type
MF9619C-38	: ST connector mounting type
MF9619C-39	: DIN connector mounting type
MF9619C-40	: SC connector mounting type
MF9619C-43	: HMS-10/A (DIAMOND) connector mounting type

1.5.3 Other Composition Units

- (1) MG9637A/MG9638A tunable laser source
See the operation manual of the MG9637A/MG9638A tunable laser source.
- (2) MN9610B/MN9611B programmable optical attenuator
See the operation manual of the MN9610B/MN9611B programmable optical attenuator.
- (3) MS9710C optical spectrum analyzer
See the operation manual of the MS9710C optical spectrum analyzer.

1.6 Specifications

1.6.1 ME7890B Optical Amplifier Test System Specifications

Measured wavelength range		1530 to 1620 nm (Accuracy guarantee wavelength range) 1525 to 1635 nm (Measurable wavelength range)
Input level range	Input signal	[Input Saturating signal] port -40 to +10 dBm/nm (MS9710C ATT: OFF) -25 to +23 dBm/nm (MS9710C ATT: ON)
	EDFA output	[A To EDFA] port +10 dBm/nm (MS9710C ATT: OFF) +23 dBm/nm (MS9710C ATT: ON)
NF measurement Accuracy*1*2		$\leq \pm 0.3$ dB (1530 to 1570 nm) $\leq \pm 0.4$ dB (1570 to 1620 nm) (In pulse method measurement in temperature change within $\pm 3^\circ\text{C}$ and in a modulation frequency of 125/250 KHz after calibration)
NF measurement reproducibility		$\leq \pm 0.2$ dB (In pulse method measurement in temperature change within $\pm 3^\circ\text{C}$ and in a modulation frequency of 125/250 kHz after calibration)
Minimum measurable channel interval		0.4 nm (50 GHz)
Function		Configuration function, data saving/recalling function, printing function
Measurement mode		Normal mode and TLS interlock measurement mode (pulse method), probe measurement mode
Measured result display	Normal	Spectrum display, table display, gain peak display
	TLS Interlock	(Wavelength, Pin, Pout) vs (NF, Gain, Pin, Pout, Pase), Spectrum display, table display
	Probe method	(Wavelength, Pin, Psat, Wsat) vs (NF, Gain, Pin, Pout, Pase), Spectrum display
Power supply		AC 85 to 132 V / 170 to 250 V, 47.5-63 Hz, 800 VA (max)
Dimensions, weight		550 (W) \times 700 (D) \times 1792 (H) mm, ≤ 250 kg
Temperature, humidity		Operating temperature: 0 to 40°C (10 to 35°C : when the MG9637A/MG9638A is used) Storing temperature: -20 to 60°C , Humidity: $\leq 90\%$ (without condensation)

*1 The details of NF measurement accuracy is shown below.

- [1] ASE level measurement accuracy : ± 0.255 dB
 Reproducibility due to optical fiber cord mounting/demounting at the time of calibration
 The error after level accuracy calibration with a power meter of a level accuracy of 2.2 % or less
 Level linearity
 Optical switch switching reproducibility
- [2] Gain (output/input) measurement accuracy : ± 0.125
 Level linearity
 Polarization-dependent characteristics
 Optical switch switching reproducibility
- [3] Wavelength resolution accuracy : ± 0.1 dB (1530 to 1570 nm)
 ± 0.2 dB (1570 to 1620 nm)
- [4] Measured wavelength accuracy : ± 0.0001 dB

Note:

Since the NF value cannot be evaluated directly because it does not have a real value, the measurement errors for the required items are regulated.

The errors are independent of each other and the final NF measurement error can be obtained by the square root of the sum of squares of the above errors.

The square root of the sum of squares of the above errors is ± 0.30 dB (1530 to 1570 nm), ± 0.40 dB (1570 to 1620 nm).

*2 The specification of the NF measurement accuracy is guaranteed when calibration and measurement are made using the FC master cord (applicable parts J0846B).

To ensure the stable operation of the ME7890B, perform warm-up of the system for about 20 minutes.

Note that all of the above specifications are satisfied after an elapse of two hours after the power is turned on.

1.6.2 MF9619C Optical Modulator Specifications

Insertion loss	Saturating signal	[Input Saturating signal] port to [A To EDFA] port ≤10 dB (1530 to 1630 nm) ≤13 dB (1530 to 1630 nm) [Option 01]
	Probe signal	[Input Probe signal] port to [A To EDFA] port ≤14 dB ≤6 dB [Option 01]
ON/OFF EXTINCTION ratio		≥65 dB
Power supply		AC 85 to 132 V / 170 to 250 V, 47.5-63 Hz, 100 VA (max)
Dimensions, weight		320 (W) × 350 (D) × 132.5 (H) mm, ≤8 kg
Temperature, humidity		Operating temperature: 0 to 40 °C, Storing temperature: -20 to 60 °C, Humidity: ≤90 % (without condensation)

1.6.3 Recommended Controllers

The requirements for the personal computer for controlling this system are shown below.

Hardware	AT compatible computer. A model in which Microsoft Windows 3.1/95/98 runs.
CPU	Pentium 75 MHz or more is recommended.
Memory	≥16 MB (≥32 MB is recommended)
Monitor	A resolution of 640 × 480 pixels or more
HDD	A free space of 20 MB or more
FDD	3.5 inches, 2HD (1.44 MB)
GPIB	National Instrument product
RS-232C	1 port (when the MG9637A/MG9638A is used as a probe signal source)

1.7 Switching the Screens

1

If the program of the ME7890B is started, the start screen appears first.
On this screen the measurement method and the language can be switched.

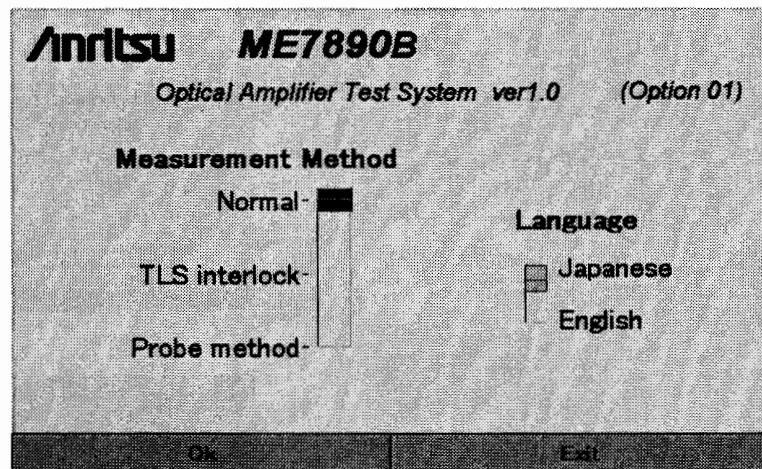

If the OK button is clicked, the selected measurement mode appears.

1.7.1 Normal Mode

If [Normal] is selected on the start screen and the [OK] button is clicked, the [Measure] screen appears. To set the measurement conditions, click the [Setup] button. To return to the measurement screen, click the [Measure] button. In the same way, to move to the calibration screen, click the [Calibrate] button.

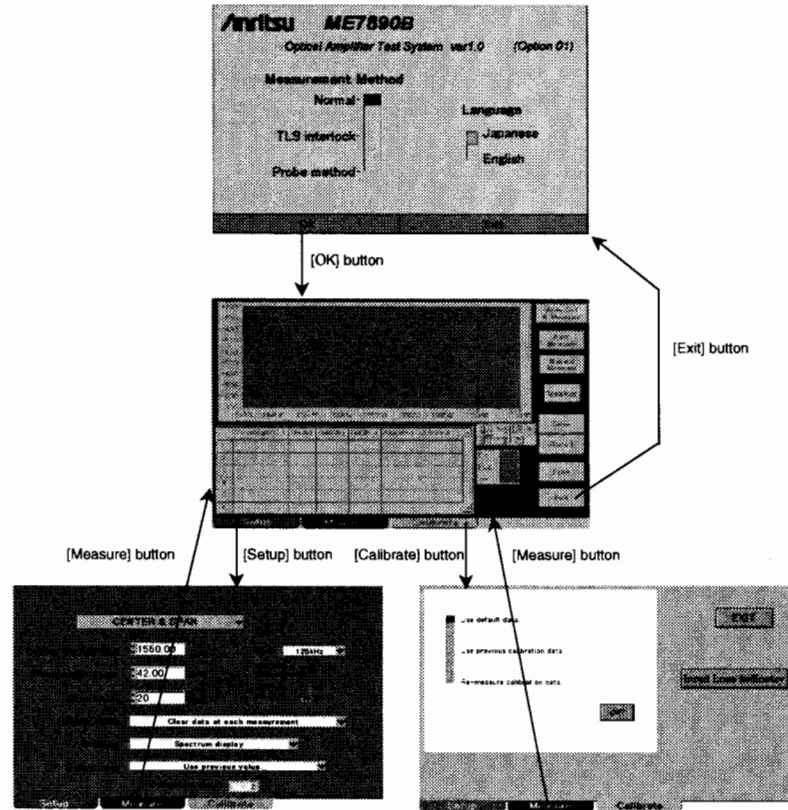

1.7.2 TLS interlock Mode

1

If [TLS interlock] is selected on the start screen and the [OK] button is clicked, the [Setup (Address)] screen appears. To set the measurement conditions, set the toggle switch at the lower right of the screen to the [Setup (Condition)] side. To return to the measurement screen, click the [Measure] button. In the same way, to move to the calibration screen, click the [Calibrate] button.

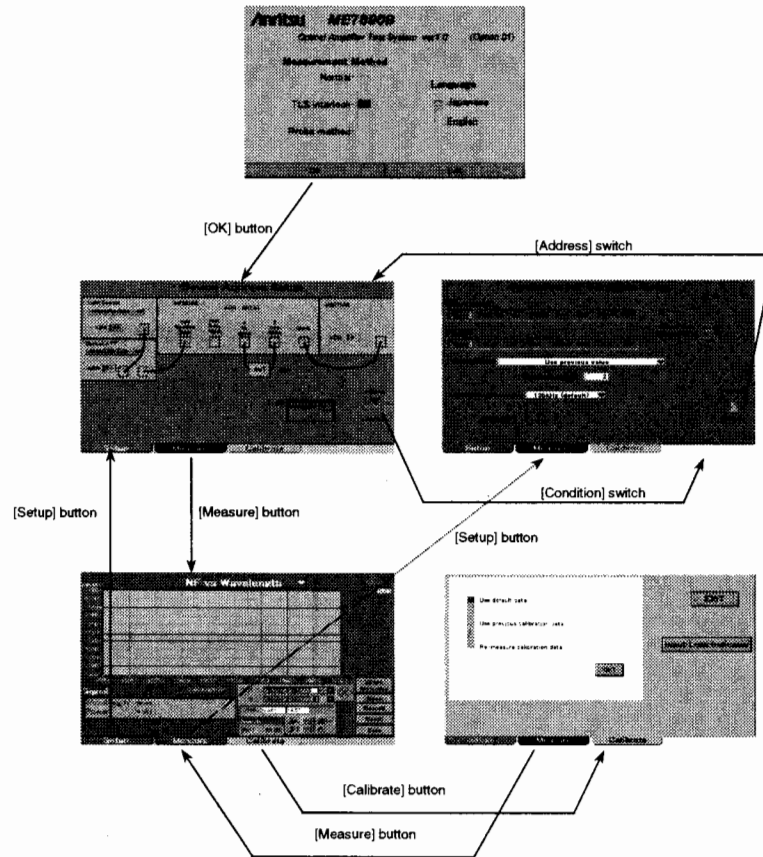

1.7.3 Probe Method Mode

If [Probe method] is selected on the start screen and the [OK] button is clicked, the [Setup (Address)] screen appears. To set the measurement conditions, set the toggle switch at the lower right of the screen to the [Setup (Condition)] side. To return to the measurement screen, click the [Measure] button. In the same way, to move to the calibration screen, click the [Calibrate] button.

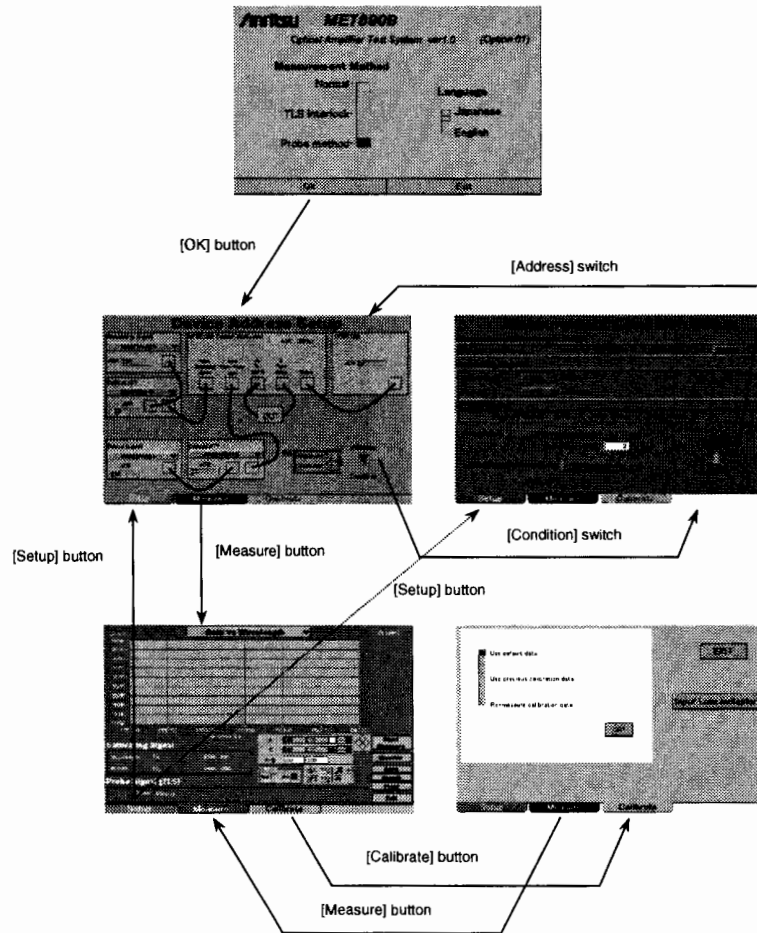

Section 2 External components and Their Functions

This section describes the layout of the measuring instruments in this system, the external features of the front and rear panels, and their functions and use.

2.1	Unpacking	2-2
2.1.1	ME7890B Optical Amplifier Test System (Standard Configuration)	2-2
2.1.2	MF9619C Optical Modulator	2-2
2.2	External Components and their Functions	2-3
2.2.1	ME7890B Optical Amplifier Test System (Standard Configuration)	2-3
2.2.2	MF9619C Optical Modulator	2-7

2.1 Unpacking

Take out the main unit and accessories from the packing box and check the components against the component list. If there should be any missing or damaged components, contact Anritsu Corp. or the distributor immediately.

For the components of the MG9637A/MG9638A tunable laser source, MN9610B/MN9611C programmable optical attenuator, and MS9710C optical spectrum analyzer, see the individual operation manuals.

2.1.1 ME7890B Optical Amplifier Test System (Standard Configuration)

Product name	Quantity	Model/ordering number
Tunable laser source	1	MG9637A
Tunable laser source	1	MG9638A
Programmable optical attenuator	2	MN9610B
Optical modulator	1	MF9619B
Optical spectrum analyzer	1	MS9710C
System rack	1	B0422A
Rack mount kit (for MG9637A/MG9638A)	2	B0423B
Rack mount kit (for MN9610B/MN9611B for using two devices in parallel)	1	B0390F
Rack mount kit (for MF9619B)	1	B0424A
Rack mount kit (for MS9710B)	1	B0423A
Operation manual	1	W1697AW

2.1.2 MF9619C Optical Modulator

Product name	Quantity	Model/ordering number
Optical amplifier test system control software	1	MX789000B (Five floppy disks for Windows 3.1/95 each)
AC power cord	1	J0017
Fuse (3.15 A)(100 V system) / (1.6 A)(200 V system)	2	F0012/F0010
Front cover	1	B0329F

2.2 External Components and their Functions

2.2.1 ME7890B Optical Amplifier Test System (Standard Configuration)

This section describes the layout of the measuring instruments of the ME7890B optical amplifier test system.

2

Front view

- [1] Eyebolt:
Used to fasten the rack to the ceiling or the wall. There are four eyebolts at the four corners on the upper surface. They can be removed by turning the screws.
- [2] System rack
- [3] MS9710C optical spectrum analyzer:
Used to perform spectrum analysis of optical signals.
- [4] Optical connector port for relay:
When the rear SLD output (option) or the reference wavelength optical output (option) of the MS9710C optical spectrum analyzer is used, this connector ports can be used as ports for relay by connecting the optical fiber cords to these ports in the rack.
- [5] MF9619C optical modulator
- [6] Cable hole:
A hole through which a GPIB cable and RS-232C cable is drawn.
- [7] Drawer type table:
A table that can be housed.
- [8] MN9610B programmable optical attenuator:
Adjusts the optical power of the probe light.
- [9] MN9610B programmable optical attenuator:
Adjusts the saturating signal light power.
- [10] MG9637A tunable laser source:
Used as a probe light source
- [11] MG9638A tunable laser source:
Used as a saturating signal light source.
- [12] Drawer type container
- [13] Breaker:
Power switch of the system
- [14] Level foot:
Used to fix the rack. The height can be changed by turning it.
- [15] Caster:
Caster for movement

CAUTION

To move this system, be sure to set the level feet at the bottom to free and move this system with casters. If this system is tilted when moving it, the precision components in this system may be stressed and damaged. After this system is moved to the desired location, put this system in a horizontal position, and then fix it with the level feet at the bottom and fasten to the ceiling using the eye bolts at the upper portion. The eyebolts on the upper surface are for fastening the system to the ceiling. If these eyebolts are used to lift and move the system rack, the system may be fallen because too large power is applied to the eyebolts. Therefore, never move this system with a crane using these eyebolts.

2

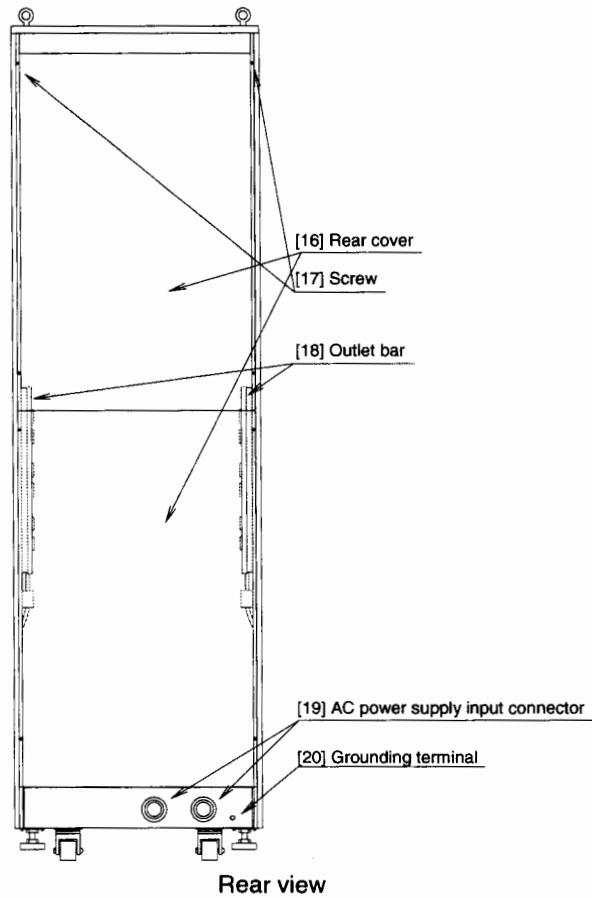

- [16] Rear cover:
The rear cover can be removed by loosening the eight screws.
- [17] Screw:
Screw with a spring. The screw can be loosen only with one-fourth turn.
- [18] Outlet bar:
Used to connect the power supply cord of each measuring instrument.
The outlet bar is placed on either side of the rack.
- [19] AC power supply connector:
An input connector of the AC power supply. It is used by connecting the power cable to both inlets.
- [20] Grounding terminal:
A terminal for grounding for safety.

2.2.2 MF9619C Optical Modulator

This section explains the name and function of each part in the MF9619C. For the MG9637A/MG9638A tunable laser source, MN9610B/MN9611B programmable optical attenuator, and MS9710C optical spectrum analyzer, see individual operation manuals.

2

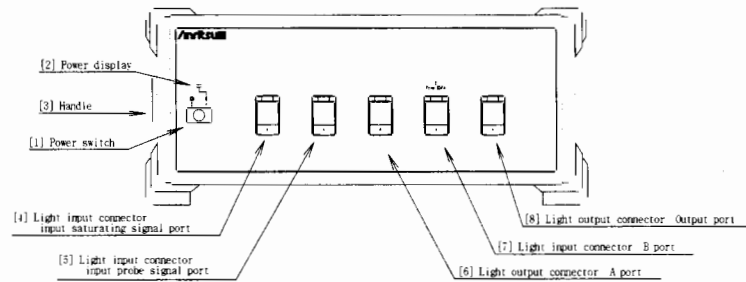

Front view

- [1] Power switch:
Power switch
- [2] Power display:
If the power is turned on, the LED indicator lights.
- [3] Handle:
On the left side of this equipment, a handle is mounted.

CAUTION

When carrying this device, keep this device horizontal as much as possible. If the person who carries this device suspends it by holding the handle that is mounted only one side, the precision components in this device may be stressed and damaged.

- [4] Saturating signal input connector (input saturating signal port):
Inputs saturating signal light. The maximum permissible input range is +10 dBm/nm when the MS9710C optical attenuator is turned off and is +20 dBm/nm when the MS9710C optical attenuator is turned on.
- [5] Probe signal input connector (input probe signal port):
Inputs probe signal light.
- [6] Light output connector (A to EDFA port):
The light input to the optical amplifier is output. It is connected to the input port of the optical amplifier that is measured using an optical fiber cord.

WARNING

The light input by the user is output from this connector. Never look into the connecting end of the optical fiber cord of the optical connector and the cord end of the connected optical fiber cord with signal light input. The output invisible laser may damage your eyes.

- [7] Light input connector (B from EDFA port):
Inputs the output light of the optical amplifier to be measured. The maximum permissible input range is +10 dBm/nm when the MS9710C optical attenuator is turned off and is +20 dBm/nm when the MS9710C optical attenuator is turned on.
- [8] Light output connector (output port):
The output light of the optical amplifier to be measured is output. It is connected to the input connector of the MS9710C optical spectrum analyzer using an optical fiber cord.

WARNING

The amplified light of the optical amplifier connected by the user is output from this connector. Never look into the connecting end of the optical fiber cord of the optical connector and the cord end of the connected optical fiber cord with the optical amplifier connected. The output invisible laser may damage your eyes.

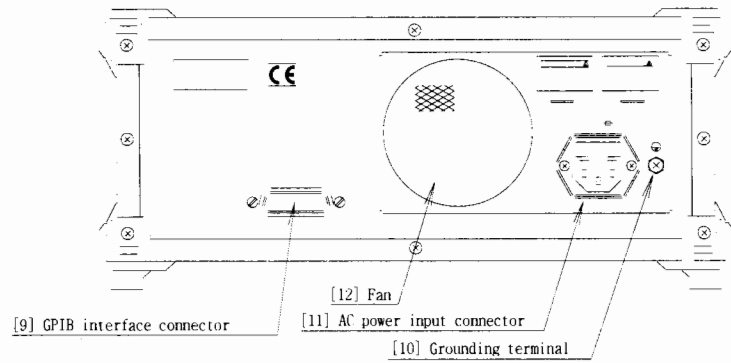
**Rear view**

- [9] GPIB interface connector:
A GPIB interface connector to connect to the external computer and the MS9710C.
- [10] Grounding terminal:
A terminal for connecting a grounding wire for safety.
- [11] AC power input connector:
An input connector of the AC power supply
- [12] Fan:
An air cooling fan that exhausts air in the MF9619C.

2-10.

Section 3 Before Using this System

This section summarizes the information to be known by the user before using the system. Be sure to read this section before using the system because the cautions to be observed for safe operation of the system and for avoiding failure are included in this section.

3.1	Grounding Conditions	3-2
3.1.1	Direction of Grounding	3-2
3.1.2	Installation Environment.....	3-2
3.1.3	Distance from the Fan.....	3-3
3.1.4	Power Supply Voltage.....	3-3
3.2	Grounding	3-4
3.3	Cautions on Vibration and Shock	3-5
3.4	Laser Safety	3-6
3.5	Connecting an Optical Fiber Cable	3-7
3.6	Replacing an Optical Connector.....	3-8
3.7	Replacing a Fuse	3-9

3.1 Grounding Conditions

3.1.1 Direction of Grounding

- (1) When a system rack is used
Install the system in a horizontal position using the level feet at the bottom of the system rack and eyebolts at the upper surface.
- (2) When a system rack is not used
If a system rack is not used, stack the MG9637A and MG9638A, the MN9610B and MN9610B, and the MF9619C and MS9710C together. In this case, stack the equipment in such a manner that each protuberance of the feet at the bottom of one instrument is fit into each hollow of the feet of the upper surface of the other instrument. If each protuberance does not fit into each hollow completely, the instruments may be turned over due to lost balance.

3.1.2 Installation Environment

This system operates at a temperature of 10 to 35 °C (0 to 40 °C if the MG9637A/MG9638A is not used). Do not use the system in the following environment to avoid the failure of the system.

- A location with vibration
- A location with much moisture and dust
- A slope
- A location exposed to direct sunlight
- A location that may be exposed to active gas
- A location that is subject to severe temperature fluctuation

If the system is moved from a low-temperature location to a high-temperature location, condensation may occur inside the system. Turning on the power in this state may cause the failure of the system due to short circuit. In this case, dry the system completely before turning on the power.

3.1.3 Distance from the Fan

- (1) When a system rack is used

There is a ventilation fan on the upper surface of the system rack. Separate the system from obstacles such as a ceiling by 20 cm or more so as not to block the air circulation. Particularly, do not put anything on the upper surface of the system rack.

- (2) When a system rack is not used

If a system rack is not used, there is a ventilation fan on each of the rear side of the MG9637A/MG9638A, the MF9619C, and the MS9710C. Separate these instruments from obstacles such as a wall and peripheral device by 10 cm or more so as not to block the air circulation.

3

3.1.4 Power Supply Voltage

Supply power in the range of 100 Vac to 120 Vac or 200 Vac to 240 Vac (47.5 to 63 Hz). The power is 800 VA or less in the standard configuration.

3.2 Grounding

(1) When a system rack is used

To supply power to the system, connect the three-pole power cord supplied with the system to the ground-type power outlet so that the system is grounded.

If a ground-type power outlet is not available, convert this three-pole power cord to a two-pole power cord using the conversion adapter. Be sure to ground the terminal of the green cable extended from the conversion adapter or the grounding terminal on the rear side of the system rack before plugging the power cord into the outlet.

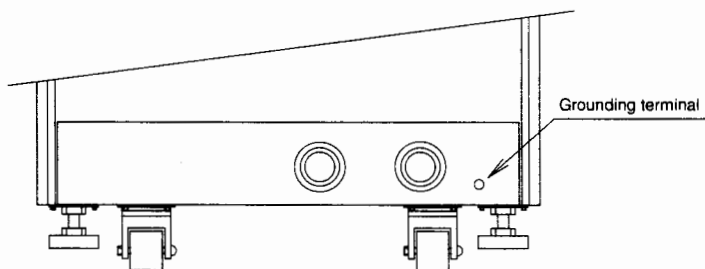

(2) When a system rack is not used

To supply power to each measuring instrument, connect the three-pole power cord supplied with each measuring instrument to the ground-type power outlet so that each measuring instrument is grounded.

If a ground-type power outlet is not available, convert this three-pole power cord to a two-pole power cord using the conversion adapter. Be sure to ground the terminal of the green cable extended from the conversion adapter or the grounding terminal on the rear side of each measuring instrument before plugging the power cord into the outlet.

WARNING

If the power is turned on without grounding the system, there is a danger of electric shock that may lead to injury or death. Be sure to connect a three-pole power cord to a ground type two-pole power supply outlet or connect the grounding wire of the conversion adapter or the grounding terminal on the rear panel to the ground.

3.3 Cautions on Vibration and Shock

The optical portion, the heart of the system, contains several micron order precision mechanical parts. Take sufficient care to avoid excessive vibration and shock when operating, saving, and carrying the system.

CAUTION

3

To move the system, be sure to set the level feet at the bottom to free and move the system with casters. If the system is tilted when moving it, the precision components in the system may be stressed and damaged. After the system is moved to the desired location, put the system in a horizontal position, and then fix it with the level feet at the bottom and fasten to the ceiling using the eyebolts at the upper portion. The eyebolts on the upper surface are for fastening the system to the ceiling. If these eyebolts are used to lift and move the system rack, the system may fall because too large force is applied to the eyebolts. Therefore, never move the system with a crane using these eyebolts.

When carrying measuring instruments when a system rack is not used, keep these instruments horizontal as much as possible. If the person who carries a measuring instrument suspends it by holding the handle that is mounted only one side, the precision components inside the measuring instrument may be stressed and damaged. Do not carry these measuring instruments in a stacked state. The measuring instruments may turn over due to lost balance.

3.4 Laser Safety

The MG9637A/MG9637A tunable laser source in the system contains a portion that emits laser beams of Class1 or Class3 in the standard of JIS, IEC825, and 21CFR1040.10.

For details, see the operation manual of the MG9637A/MG9638A.

In the system, if a signal light is input to the MF9619C, the signal light is output from Port A. If the optical amplifier is connected to the system, amplified light is output from the output port. Never look into the connecting end of the optical fiber cord of these ports and the cord end of the optical fiber cord connected to these ports. The output invisible laser may damage your eyes.

3.5 Connecting an Optical Fiber Cable

The connection of the optical fiber cord for measurement differs depending on the measurement mode and system configuration. See Section 6 and later for the measurement mode.

If you use a system rack and the SLD light source option or the reference wavelength light source option of the MS9710C optical spectrum analyzer, it is convenient to connect the optical fiber cord from the optical connector on the rear side of the MS9710C to the optical connector for relay.

3

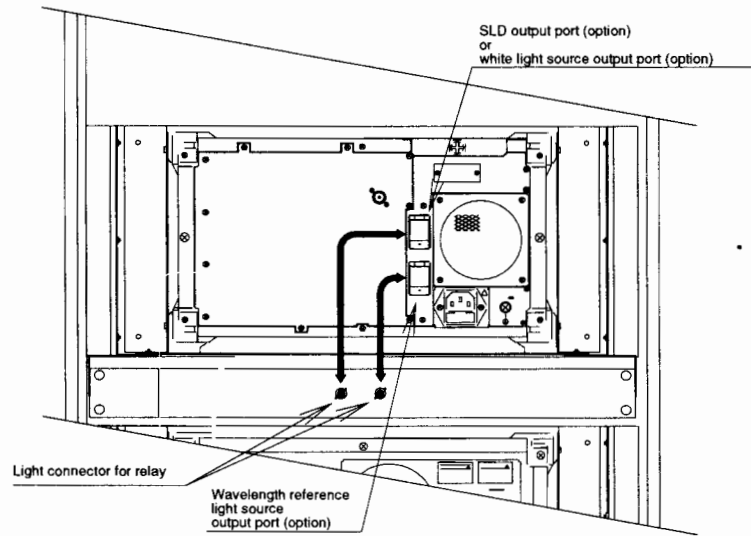

Before connecting the optical fiber cord, clean the end of the optical fiber cord.

 12.1.4 Cleaning optical fiber cords

CAUTION

Before connecting the optical fiber cord, be sure to clean the end of the optical fiber cord. Also make a check periodically to ensure that the optical connector of the system is cleaned. If the optical connector is used with dirt on it, the parts may be burnt.

3.6 Replacing an Optical Connector

Unless otherwise specified, an FC connector (F0617B) is installed on the light input/output connectors. These connectors can be replaced with one of the following connectors.

Type	Product name	Ordering number
FC connector	Replaceable optical connector (FC)	J0617B
ST connector	Replaceable optical connector (ST)	J0618D
DIN connector	Replaceable optical connector (DIN)	J0618E
SC connector	Replaceable optical connector (SC)	J0619B
HMS-10/A (DIAMOND) connector	Replaceable optical connector (HMS-10/A)	J0618F

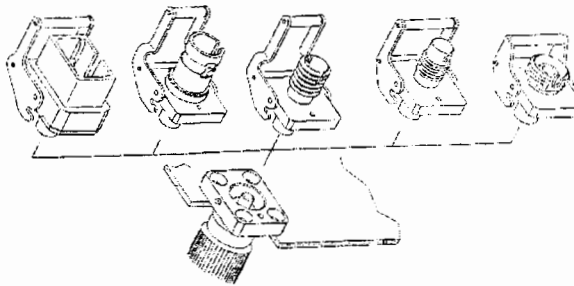

To remove the connector, follow the procedure below. For the cleaning method, see Section 12.1.3.

12.1.3 Cleaning optical connectors

- 1 Open the connector cover
- 2 Lift the connector lever towards you. After confirming that the latch is opened, gently pull out the connector towards you horizontally.

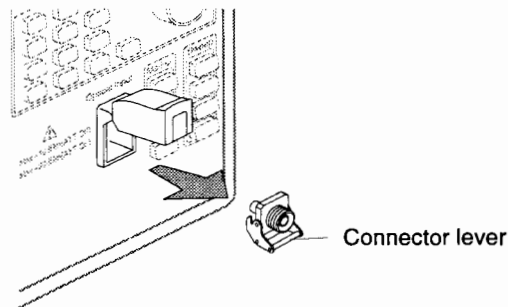

- 3 To install the connector, follow the reversal of the removal. Take sufficient care not to damage the end of the ferrule with a connector when installing the connector.

3.7 Replacing a Fuse

If a fuse is blown, eliminate the cause and replace the fuse in accordance with the procedure below.

CAUTION

Before replacing the fuse, be sure to plug out the power cord. If the fuse is replaced without plugging out the power cord, there is a danger of electric shock.

For a fuse for replacement, use a fuse of the same rating or performance indicated on the rear side of the chassis. T3.15A in the fuse display indicates a time-lag type fuse.

3

Fuse replacement procedure

- 1 If a system rack is used, remove the rear cover of the system rack by turning the eight screws on the rear side of the rack one-quarter turn counter-clockwise with a Phillips screwdriver.

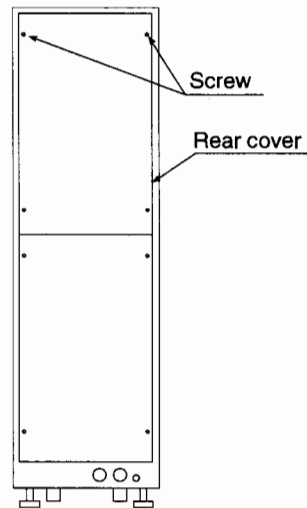

CAUTION

When removing the rear cover of the system rack, remove the screws while holding the rear cover with your hands. If the rear cover is removed without holding with your hands, there is a danger of injury caused by the rear cover that falls down on your feet.

Section 3 Before Using this System

- 2 Around the AC power supply input connector on the rear side of each measuring instrument in the system, there are two fuse holders. Turn the caps of these fuse holders with a screwdriver to open them.

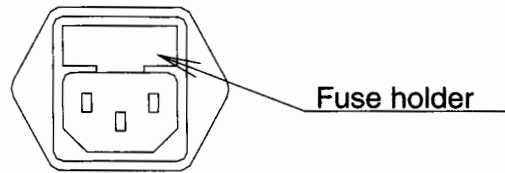

- 3 Replace the blown fuse. Note that the product name of the fuse differs depending on the power supply voltage used.

Model name	100 V system	200 V system
MG9637A/MG9638A	T5A250 V	T3.15A250 V
MN9610B/MN9611B	T1.6A250 V	T0.8A250 V
MF9619C	T3.15A250 V	T1.6A250 V
MS9710C	T3.15A250 V	T1.6A250 V

- 4 Re-install the cap of the fuse holder.
- 5 If a system rack is used, re-install the rear cover.

Section 4 Setting Up the System

This section describes the setup procedure of the MX789000B optical amplifier test system control software for controlling the entire system, from the installation of this software to the personal computer to the start of measurement.

4.1	Operating Environment	4-2
4.2	Installing Software	4-3
4.3	Setting Up Devices.....	4-4
4.4	Starting/Exiting the Program.....	4-5
4.4.1	Starting the Program.....	4-5
4.4.2	Exiting the Program	4-5
4.4.3	Re-starting the Program.....	4-6
4.4.4	Closing the Window	4-6



4.1 Operating Environment

This software operates in the following environment.

Hardware	AT compatible computer. A model in which Microsoft Windows 3.1/95 runs.
CPU	i486DX or more (Pentium 75 MHz or more is recommended.)
Memory	16 MB or more (32 MB or more is recommended.)
Monitor	A resolution of 640 (480 pixels or more
OS	Windows 3.1 or Windows 95
Hard disk	A free space of 20 MB or more
GPIB interface	National Instrument product
FDD	3.5 inches, 2HD (1.44 MB)

Before installing the software, confirm that GPIB operates normally by installing the GBIP interface board and the NI-488.2 software to the personal computer. For the NI-488.2 software, use the latest version.

4.2 Installing Software

This section describes the installation method of the MX789000B optical amplifier test system control software. It is recommended that a backup file be created to provide against accidents.

- Turn on the power of the personal computer and start Windows.
- Insert Floppy disk No. 1 (1/5) into the FD drive.
- Floppy disks (FD) for Windows 3.1 and those for Windows 95 are provided. Use appropriate ones.
- Start the Windows Explorer (File Manager if you use Windows 3.1) and select the FD drive into which the floppy disk is inserted.
- Double-clicking Setup-exe will start the install program.
- The directory to install the software is "C:ME7890" by default. To install the software in another directory, click the [Change] button and type in the directory, and then click the [OK] button.
- If the [Finish] button is clicked, installation will start.

After that, follow the instruction of the installer.

Installation of the software to the personal computer is completed.

4.3 Setting Up Devices

Connect each measuring instrument to the personal computer using GPIB cables. If the tunable laser source is to be used as a probe light in the probe method measurement mode, connect the MS9710C optical spectrum analyzer to the personal computer with an RS-232C cable. For details, see the description of each measurement mode in Chapter 6 and later.

- After checking that the power switch is turned off, ground the measuring instruments in accordance with [3.2 Grounding a Wire]. Also ground the personal computer used.
- Connect the power inlet on the rear side to the outlet using a power cord.
- Turn on the power of each measuring instrument.
- Set the addresses of the measuring instruments. The address of the MF9619C optical modulator is the fixed value 19 (it cannot be changed). For the setting method of other measuring instruments, see individual operation manuals.
- After heating up, adjust the optical axis (Auto Align) and calibrate the wavelength (W1 Cal) of the MS9710C. (For details, see the MS9710C Operation Manual.)

4.4 Starting/Exiting the Program

4.4.1 Starting the Program

If you use Windows 3.1, double-click the [ME7890B] icon in the [ME7890] group in Program Manager. If you use Window 95, click [Start] → [Program] → [ME7890] → [ME7890B].

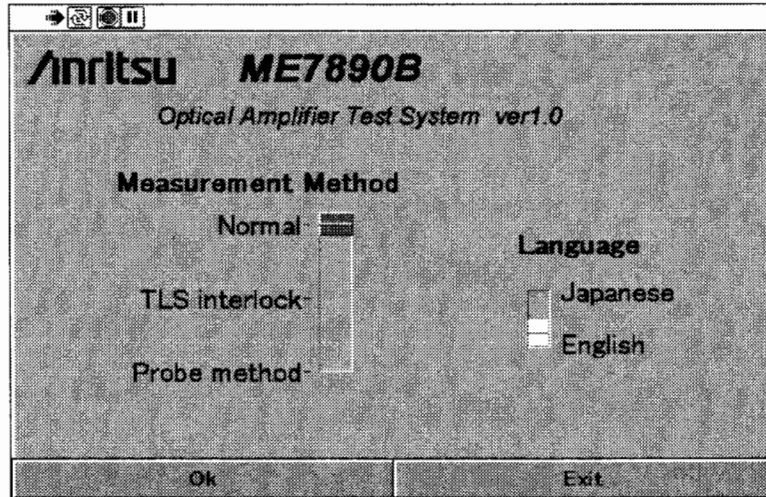

4

The program is started automatically and the start panel appears.

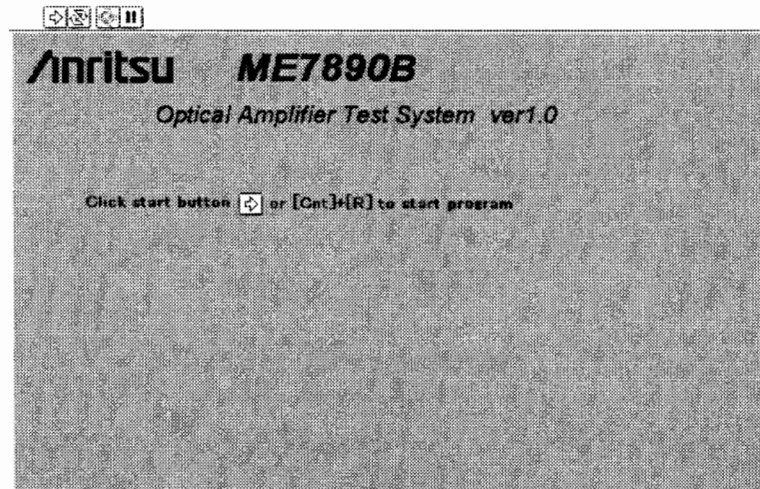

4.4.2 Exiting the Program

If the [Exit] button is clicked on the start panel, the program is exited.



4-5

4.4.3 Re-starting the Program

To re-start the program after exiting the program, click the start button  on the menu bar. The start button changes to  and the program re-starts.

4.4.4 Closing the Window

To close the window after the program is exited, select [Close] in the [File] menu.

Section 5 Measurement Mode

This section describes the outline of each measurement mode. For details, see Section 6 and later.

5.1	General	5-2
5.2	Normal Mode (Pulse Method)	5-3
5.3	Tunable Laser Source Interlock Measurement Mode (Pulse Method)	5-4
5.4	Optical Pulse Probe Method Measurement Mode	5-5

5.1 General

The ME7890B optical amplifier test system has the following three measurement modes.

- 1) Normal mode (pulse method)
- 2) Tunable laser source interlock measurement mode (pulse method)
- 3) Optical pulse probe measurement mode

Select an appropriate mode depending on your system.

The mode can be selected with [Measurement Method] switch on the start panel.

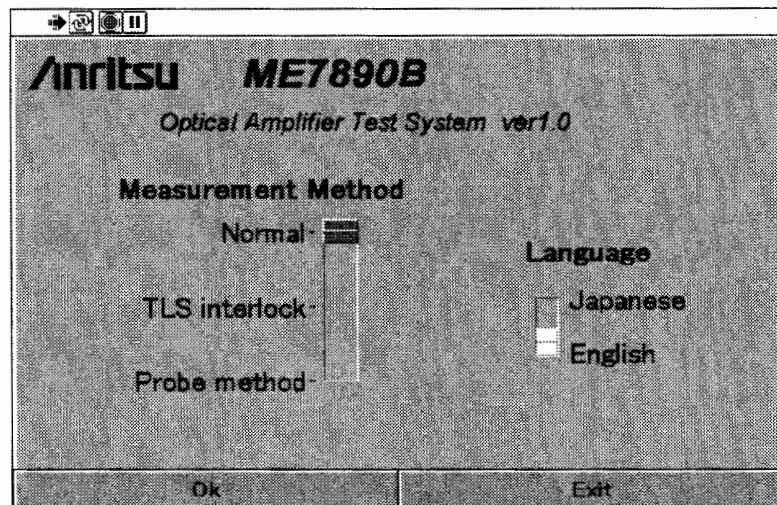

Start panel

5.2 Normal Mode (Pulse Method)

In the normal mode, the NF and gain are measured using the optical pulse method. It is used to accurately measure the NF/gain of the optical amplifier under the actual use state. Pulse Method measurement is the highest accurate measurement and its result becomes the reference value of NF/gain when a probe method measurement (see later) is made.

The system consists of the MF9619C optical modulator, MS9710C optical spectrum analyzer, and the MX789000B system software. The personal computer controls the MF9619C and MS9710C through GPIB.

A single mode oscillating light source such as DFB-LD light source as well as a WDM light source can be used as the signal light source. The system detects the input signal light wavelength automatically and measures NF/gain in each wavelength collectively.

5

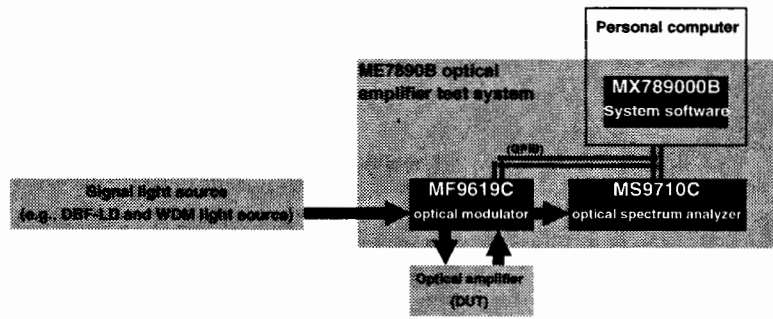

System configuration

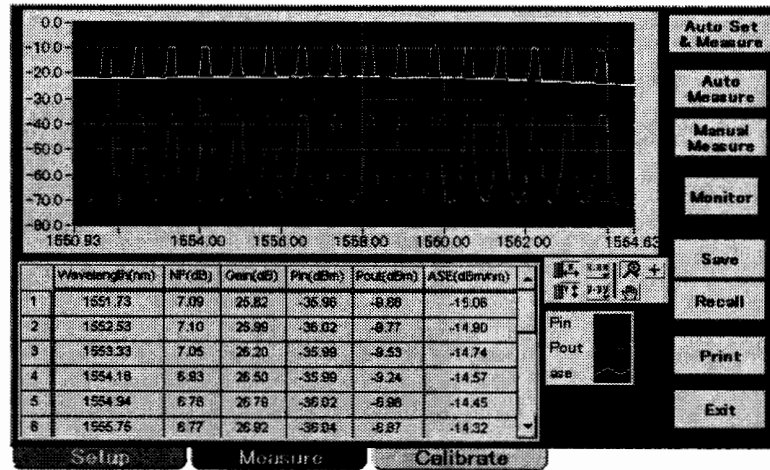

Measurement example

5.3 Tunable Laser Source Interlock Measurement Mode (Pulse Method)

In the tunable laser source interlock measurement mode, the wavelength characteristics and the input power characteristics of the NF/gain are measured while controlling the tunable laser source and programmable optical attenuator.

It is used to measure the general characteristics of the optical amplifier.

The system consists of the MG9637A/MG9638A tunable laser source, MN9610B/MN9611B programmable optical attenuator, MF9619C optical modulator, MS9710C optical spectrum analyzer, and the MX789000B system software. Each device is controlled by a personal computer.

The users who are using the MX789000B option 01 can also use the HP8168D/E/F as a signal light source and the HP8156A as a programmable optical attenuator.

In the manual mode, other light sources and optical attenuators can also be used. Measurement can be made without an optical attenuator.

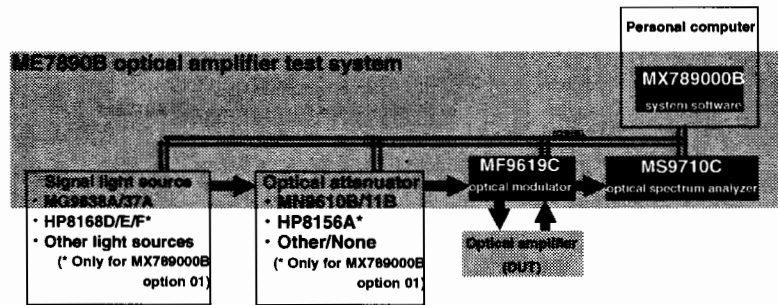

System configuration

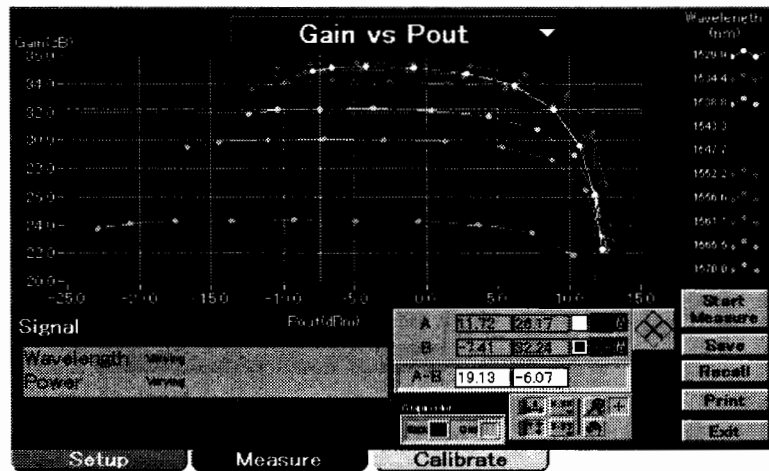

Measurement example

5.4 Optical Pulse Probe Method Measurement Mode

In the optical pulse probe method measurement mode, measurement is made in the optical pulse probe method. Only with one or several saturating signals, measurement equivalent to the state in which WDM signals are input can be made in a short period. With this method, the plant and equipment investment and the inspection man-hours in the manufacturing and inspection process steps of optical amplifiers can be reduced significantly.

What is the probe method?

It is a method in which the wavelength characteristics are measured using weak lights (probe signals) that do not change the state of the optical amplifier.

The saturating signal is input to generate a state equivalent to that in which the optical amplifier is actually used. In the test of the optical amplifier for wavelength division multiplex communication, the state equivalent to the WDM signal input state can be obtained by replacing the WDM light source with one or several saturating signals.*

The probe signal is an input signal for measurement. The NF/gain can be measured from the response to the probe signal by the optical amplifier. As a probe light source, either the tunable laser source (TLS) or the wide-band laser source is used to make measurement of a wide wavelength range at the same time.

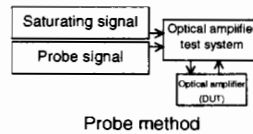

* The measurement error due to the reduction in the number of saturating signals depends on the characteristics of the optical amplifier to be tested (DUT), the number of saturating signals, wavelength, power, and probe light power. It is recommended that the number of saturating signals, wavelength, power, and probe light power be determined while comparing the measured results in the pulse method measurement.

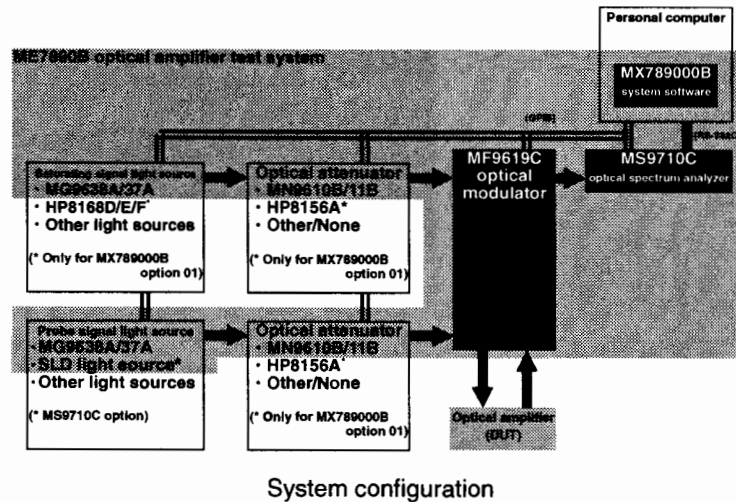

5

The RS-232C cable in the figure is required when the MG9637A/38A is used as a probe light source.

If the MG9637A/38A is used as a probe light source, the measurement accuracy equivalent to the pulse method can be obtained. Since measurement is made while synchronizing the setting wavelength of the tunable laser source and the measurement wavelength of the MS9710B optical spectrum analyzer, the measurement time can be reduced.

It is also possible to use the SLD light source (MS9710C option) and other wide-band light sources as a probe light source. In this case, the measurement time can be further shortened though the measurement accuracy is lower than that of the tunable laser source because the input light power per optical spectrum analyzer setting resolution width is reduced. As the MF9619C optical modulator, use the MF9619C-01 (SLD compatible type), which has a smaller loss for the probe light input port. The insertion loss of the probe light input port is improved by about 8 dB. (The insertion loss of the saturating signal input port is degraded by about 3 dB.)

The users who are using the MX789000B option 01 can also use the HP8168D/E/F as a saturating signal light source and the HP8156A as an optical attenuator.

In the manual mode, other light sources and optical attenuators can also be used. Measurement can be made without an optical attenuator.

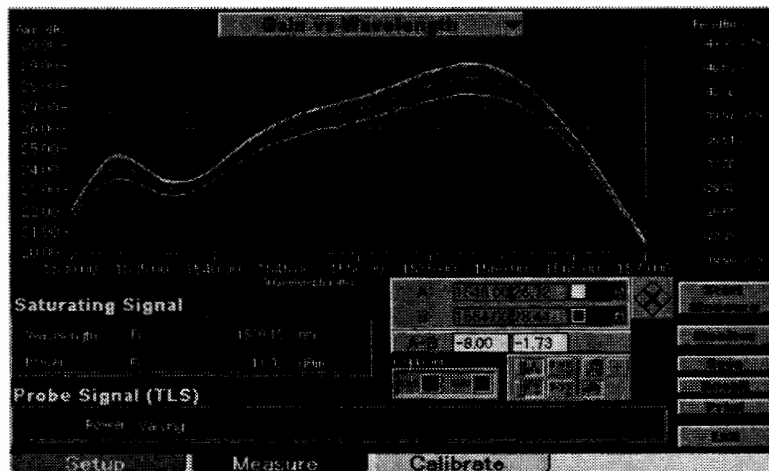

Measurement example

Section 6 Normal Measurement Mode

This section describes the measurement method in the normal measurement mode (pulse method) and other detailed information. In the normal mode, the NF/gain is measured using the optical pulse method. It is used to accurately measure the NF/gain of the optical amplifier under the actual use state. Pulse method is the highest accurate measurement and its result becomes the standard value of the NF/gain when a probe method measurement (described in the later section) is made. To ensure the accuracy of the measured results, be sure to perform calibration before making a measurement. For the detail of calibration, see “Section 9 Calibration.”

6.1	Setup.....	6-2
6.1.1	Connecting GPIB Cables.....	6-2
6.1.2	Connecting Optical Fiber Cords.....	6-2
6.2	Measurement.....	6-3
6.2.1	Auto Set & Auto Measure Button.....	6-3
6.2.2	Auto Measure Button.....	6-3
6.2.3	Manual Measure Button.....	6-4
6.3	Displaying Measured Results.....	6-6
6.3.1	Spectrum Display.....	6-6
6.3.2	Data Table Display.....	6-7
6.3.3	Gain Peak Display.....	6-7
6.4	Printing.....	6-8
6.5	Saving and Recalling Measured Results.....	6-9
6.6	Power Monitor Function.....	6-10
6.7	Selecting Data Clear.....	6-11



6.1 Setup

6.1.1 Connecting GPIB Cables

Connect the MF9619C, the MS9710C, and the personal computer with GPIB cables.

Turn on the power of the devices in accordance with the setup instruction in “Section 4 Setting Up the System” and start the system software. After setting the [Measurement Method] switch on the start panel to [Normal] and set the [Language] switch to [English], click the [OK] button. The measurement panel will appear.

6.1.2 Connecting Optical Fiber Cords

Connect optical fiber cords as shown in the following figure. In the normal mode, do not connect anything to the [Input Probe Signal] port.

6.2 Measurement

There are three methods of measurement. The following three buttons on the screen has a one-to-one correspondence with the three methods.

- Auto Set & Auto Measure button
- Auto Measure button
- Manual Measure button

These buttons are described below.

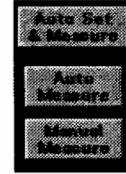

6.2.1 Auto Set & Auto Measure Button

Full automatic measurements are made with one button.

After detecting signals in all the measurement wavelength range between 1525 to 1635 nm and setting the delay time (compensation of the delay time caused by the optical amplifier (👉 14.3 Delay Time)), the system measures the input light power, amplified light power, and ASE power in this order and displays the calculation results of the NF and gain.

6.2.2 Auto Measure Button

Signals are detected within the wavelength range set on the setup panel and automatic measurement is made after that. This method is used to make a measurement only within the limited wavelength range as opposed to [Auto Set & Auto Measure] that makes a measurement in all wavelengths including those other than the signal wavelength.

The wavelength range is set on the setup panel. Enter values into the [Start Wavelength] and [Stop Wavelength] boxes directly.

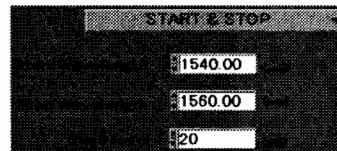

Besides the above method, the method of specifying the wavelength with the center wavelength and the sweeping width can be selected. To select the wavelength input method, click the [START & STOP] button and specify from the drop-down list.

In the Slice Level box, specify the slice level. When detecting signals, only a light that has a power larger than the power obtained by subtracting the slice level from the peak level is detected as a signal.

To shorten the measurement time, it is possible to omit the setting of the [delay time] in accordance with the instruction on the setup screen. [Delay time] is specified for compensating for the delay time caused by the optical amplifier when measuring the ASE level. 👉 14.3 Delay Time

Adjust at start of each measurement.

If the ▼ in the [Delay time] list box on the setup panel is clicked, a list of options is displayed.

Adjust at start of each measurement.
 Adjust only at first measurement.
 Use previous value.

If [Adjustment at start of each measurement] is selected, [Delay time] is adjusted before the start of the [Auto Measure] measurement every time.

If [Adjustment only at first measurement] is selected, [Delay time] is adjusted only before the initial [Auto Measure] measurement and the [Delay time compensation value] in the previous measurement is used in the second and later measurement instead of adjusting the [Delay time].

If [Use previous value] is selected, the [Delay time compensation value] in the previous measurement is used.

6.2.3 Manual Measure Button

This button is used to measure only certain signal wavelengths.

If the [Manual Measure] button is clicked, the manual measurement screen appears.

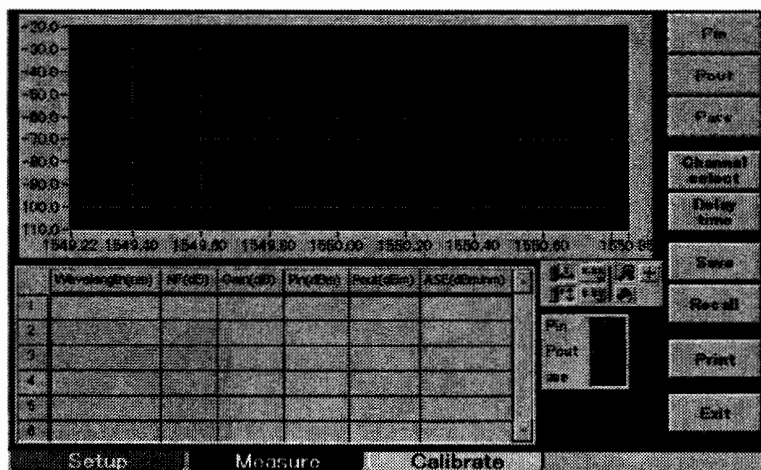

Click the [Channel select] button first. After the spectrum measurement of the input light is completed, the signal light wavelengths are listed as shown below.

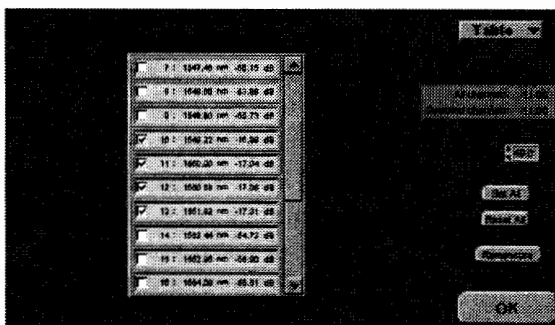

Select the wavelength by clicking the check box at the left of the desired wavelength. A check mark is indicated at the selected wavelength. To display hidden wavelengths, use the scroll bar at the right of the table. If the ▼ mark of the [Table] list box is clicked and [Graph] is selected, the wavelength can be selected on the graph display screen.

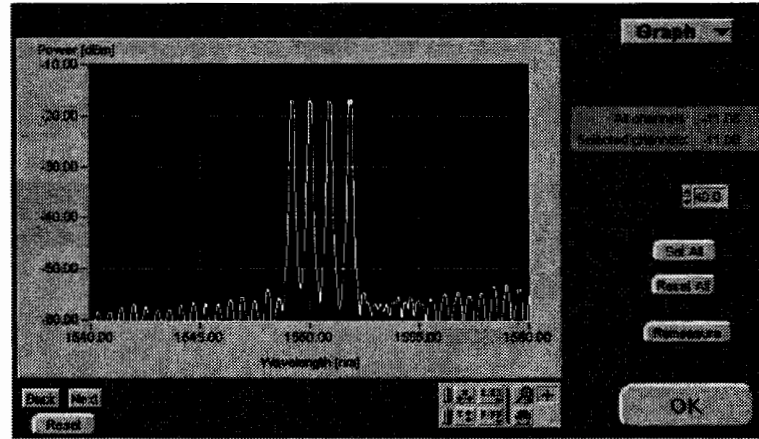

6

The wavelength indicated with a yellow circle is the presently selected wavelength. If the marker movement button  at the lower right of the graph is pressed, the selected wavelength can be moved by drawing the mouse. The selected wavelength can also be moved by clicking the Next/Back button. If the [Set] button is clicked, the selected wavelength is set and the button name is switched to [Reset]. If the [Reset] button is clicked, the selected wavelength is canceled.

Select one or more wavelengths and click the [OK] button.

Next, click the [Pin], [Pout], and [Pase] buttons in this order to measure the input light power, the amplified light power, and the ASE power.

Set a value in the range of 0 to 15 to [Delay time] so that the amplified light is not leaked when measuring [Pase].

14.3 Delay Time

To exit Manual Measure, click the [Exit] button.

6.3 Displaying Measured Results

To display the measured results, the following three types of display may be used.

- Spectrum display
- Data table display
- Gain peak display

Select the display type from the drop-down list on the setup screen.

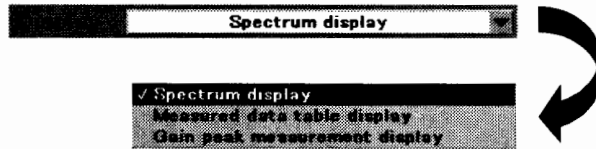

6.3.1 Spectrum Display

This display is used to display the spectrum of input light, amplified light and ASE.

The calculation result of the NF is displayed in the table under the graph.

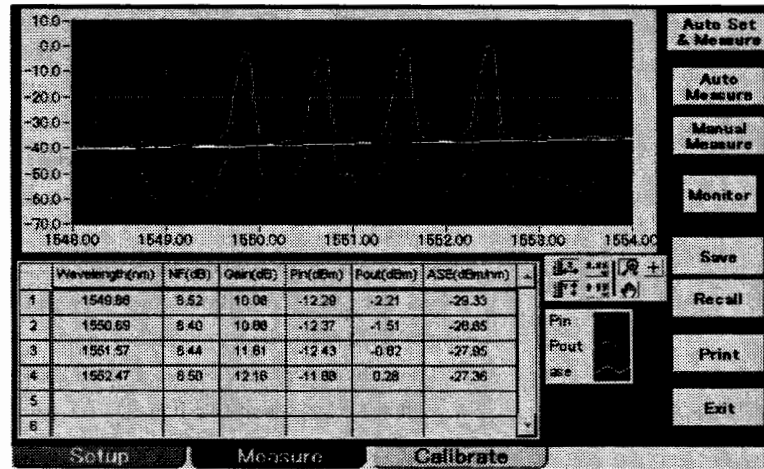

The vertical axis of the graph indicates the power. The unit is dBm.

The horizontal axis of the graph indicates the wavelength. The unit is nm.

6.3.2 Data Table Display

This display is used to display only the table. When there are many channels, the data becomes easy to see in this mode.

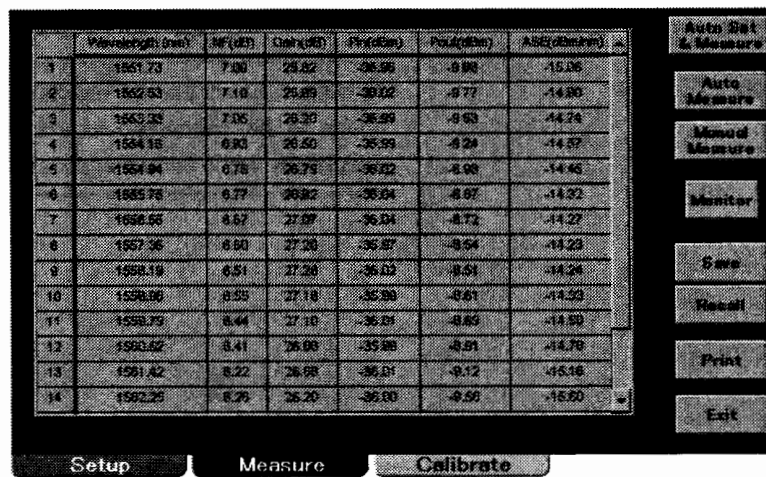

	Wavelength(nm)	NF(dB)	Gain(dB)	PreGain	PostGain	ASE(dBm/nm)
1	1551.73	7.00	25.82	-35.95	-8.90	-15.06
2	1552.53	7.10	25.89	-36.02	-8.77	-14.90
3	1553.33	7.20	25.95	-36.09	-8.63	-14.74
4	1554.15	6.90	26.50	-35.99	-8.24	-14.57
5	1554.94	6.78	26.79	-36.02	-8.08	-14.45
6	1555.75	6.77	26.82	-36.04	-8.07	-14.32
7	1556.55	6.57	27.07	-36.04	-8.73	-14.22
8	1557.36	6.80	27.20	-35.87	-8.94	-14.23
9	1558.18	6.51	27.20	-36.02	-8.51	-14.24
10	1558.99	6.53	27.18	-35.88	-8.61	-14.53
11	1559.79	6.44	27.10	-36.01	-8.85	-14.53
12	1560.62	6.41	26.95	-35.88	-8.81	-14.70
13	1561.42	6.22	26.98	-36.01	-9.12	-15.16
14	1562.25	6.25	26.20	-35.88	-8.55	-15.50

Control Panel: Auto Set & Measure, Auto Measure, Manual Measure, Monitor, Save, Recall, Print, Exit. Bottom buttons: Setup, Measure, Calibrate.

6

To display hidden wavelengths when all data cannot be displayed on one screen because there are too many channels, use the scroll bar at the right of the table.

6.3.3 Gain Peak Display

This display is used to display the wavelength characteristics of the NF and gain.

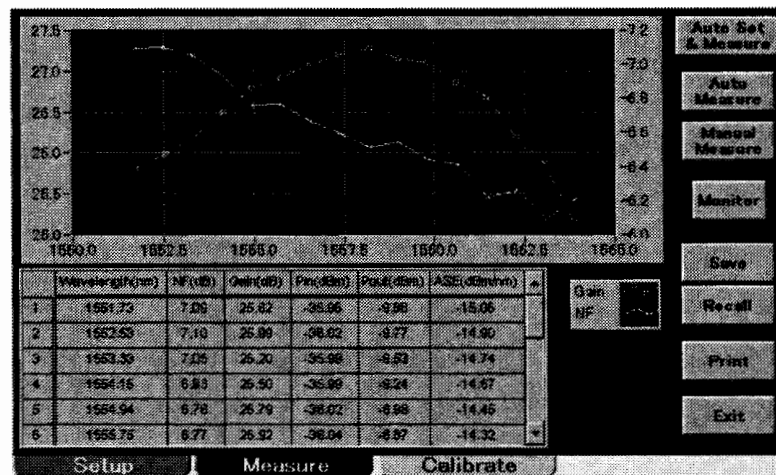

The left and right vertical axes of the graph indicate the gain and NF, respectively.

The unit is dB. The horizontal axis indicates the wavelength. The unit is nm.

6.4 Printing

To output the measured results to the printer, click the [Print] button.

CAUTION

To output the measured results to the printer, the printer needs to be connected to the personal computer and enabled by the Windows application program.

6.5 Saving and Recalling Measured Results

The measured data can be saved in the hard disk of the personal computer. If the [Save] button is clicked, the file dialog box appears. (See the figure below.)

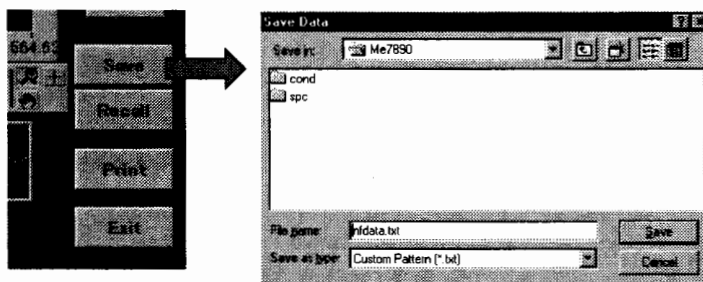

Select the drive and directory in which the data is to be saved. In the box for the file name entry, the name [nfdata.txt] is entered in advance. To change the name, move the cursor into the file name input box with the mouse and type in the name from the keyboard. Do not forget to attach the extension [.txt] to the file name.

6

If the [Save (S)] button is clicked, the data is saved.

(The file dialog box differs depending on the OS type.)

To recall the saved data, click the [Recall] button. After the file dialog box appears, select the file name to be recalled and click the [Open (O)] button.

6.6 Power Monitor Function

By using the power monitor function, the light power input to the optical amplifier or the power output from the optical amplifier can be monitored. Click the [Monitor] button and select Pin (input light power) or Pout (output light power).

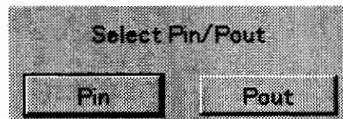

If the channel to be monitored on the channel select panel is selected and the [OK] button is clicked, the following panel appears and monitoring starts.

#	Wavelength (nm)	Pin (dBm)	-dif (dB)	+dif (dB)
1	1540.000	-2.00	0.00	0.44
2	1550.000	-3.07	-0.09	0.86
3	1551.660	-3.07	-0.10	0.36
4	1552.000	-3.42	-0.44	0.00

Num. of Channel	4	Max	No. 1	Min	No. 4
Total Power	2.89 dBm	Wave	1549.00 nm	Wave	1552.50 nm
Max-Min	0.44 dB	Power	-2.90 dBm	Power	-3.42 dBm

The wavelength and power in each channel are measured continuously. If there are too many channels and they cannot be displayed on one screen, the hidden channels can be displayed with the scroll bar at the right of the table. In the [-dif] column, the difference in power between the selected channel and the channel having the maximum power is displayed. In the [+dif] column, the difference in power between the selected channel and the channel having the minimum power is displayed. Under the table, the number of channels, the sum total of powers of these channels, the difference between the maximum and minimum powers, and the maximum (minimum) channel information are displayed. If the VBW switch is set to 1 kHz, a high-speed measurement is made. If it is set to 100 Hz, a high-accuracy measurement is made. With the list at the upper portion of the table, the display can be switched between the input light power and the output light power.

6.7 Selecting Data Clear

When the NF/gain wavelength characteristics are measured with a tunable laser source, data of each measurement is left on the screen and a measurement is made while changing the wavelength.

To leave the measured data, select [Save measurement results] or [Select data save/clear at measurement start] on the setup screen.

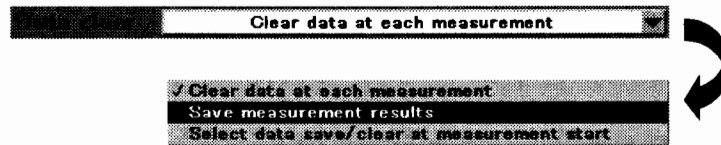

If [Save measurement results] is selected, the table data in each measurement is not cleared and left on the screen. If [Select data save/clear at measurement start] is selected, the dialog box asking whether to clear the table data is displayed when starting a measurement. If the [No] button is clicked, the table data is not cleared and the measured results are displayed from the line next to the last line.

To graph the wavelength characteristics, select [Gain Peak Measurement Display] from the [Display] drop-down list on the setup screen.

6

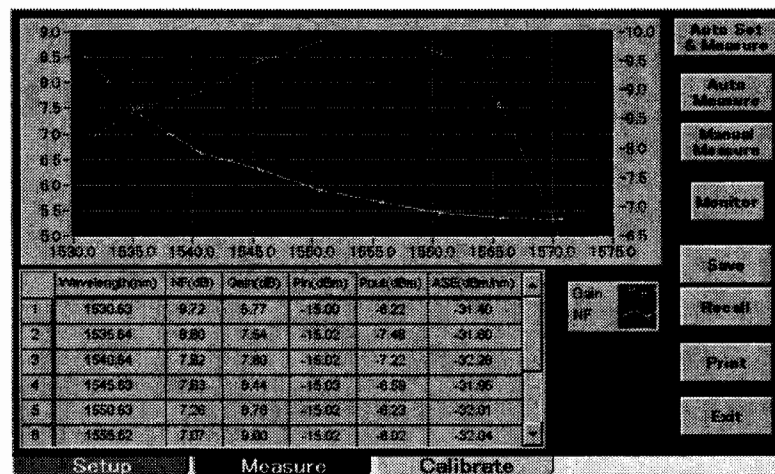

The above screen shows an example of the measurement of wavelength characteristics in intervals of 5 nm using a tunable light source.

6-12.

Section 7 Tunable Laser Source Interlock Measurement Mode

This section describes the measurement method in the tunable laser interlock measurement mode (TLS interlock measurement mode) and other detailed information. In the tunable laser interlock measurement mode, the wavelength characteristics and the input power characteristics of the NF/gain are measured while controlling the tunable laser source and programmable optical attenuator in the optical pulse method. It is used to measure the general characteristics of the optical amplifier.

To ensure the accuracy of the measured results, be sure to perform calibration before making a measurement. For the detail of calibration, see “Section 9 Calibration.”

7.1	Setup.....	7-2
7.1.1	Connecting GPIB Cables	7-2
7.1.2	System Setting.....	7-3
7.1.3	Connecting Optical Fiber Cords.....	7-4
7.1.4	Setting the Measurement Conditions.....	7-5
7.2	Measurement	7-7
7.3	Displaying Measured Results.....	7-9
7.4	Printing.....	7-11
7.5	Saving and Recalling Measured Results.....	7-12

7.1 Setup

7.1.1 Connecting GPIB Cables

Connect the MF9619C, the MS9710C, the tunable laser source, the programmable optical attenuator, and the personal computer with GPIB cables. Set the GPIB address of the MN9610/11B programmable optical attenuator with the dip switch assembly on the rear side. (For details, see the operation manual of the MN9610/11B programmable optical attenuator.) Set the GPIB address of other devices by operating the keys after turning on the power.

7.1.2 System Setting

Turn on the power of the devices in accordance with the setup instruction in [Section 4 Setting Up the System] and start the system software. After setting the [Measurement Method] switch on the start panel to [TLS Interlock] and set the [Language] switch to [English], click the [OK] button. The device address setting screen will appear.

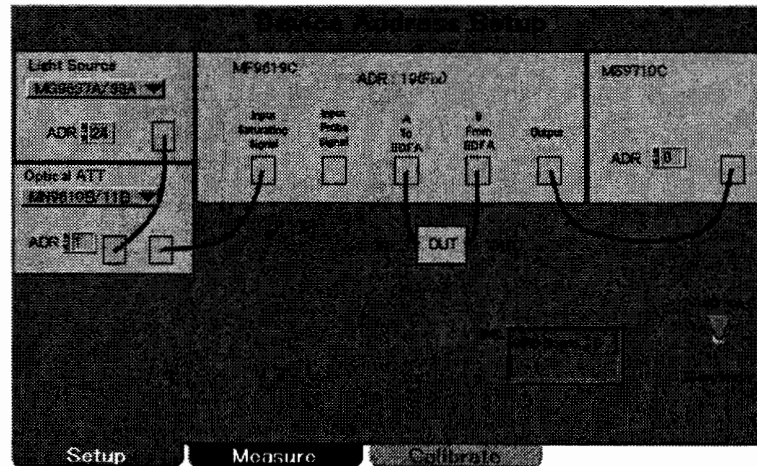

In the [Light Source] list box, select the type of the tunable laser source. The users who are using the MX789000B option 01 can also use the HP8168D/E/F. If another tunable laser source or fixed wavelength light source is to be used, select [Another Signal]. In this case, control by GPIB is not performed.

In the [Optical ATT] list box, select the type of the optical attenuator. The users who are using the MX789000B option 01 can also use the HP8156A. If another optical attenuator is to be used or if an optical attenuator is not to be used, select [None]. In this case, control by GPIB is not performed.

In the [ADR] box, enter the GPIB address of each device. The GPIB address of the MF9619C is fixed to 19. For the GPIB address setting method of other devices, see the operation manual of each device. Set the GPIB address in the range 1 to 30. Do not set the same address to different devices.

7.1.3 Connecting Optical Fiber Cords

Connect optical fiber cords in accordance with the instructions on the [Device Address Setup] panel. In the tunable laser interlock measurement mode, the [Input Probe Signal] port is not used. Do not connect anything to this port.

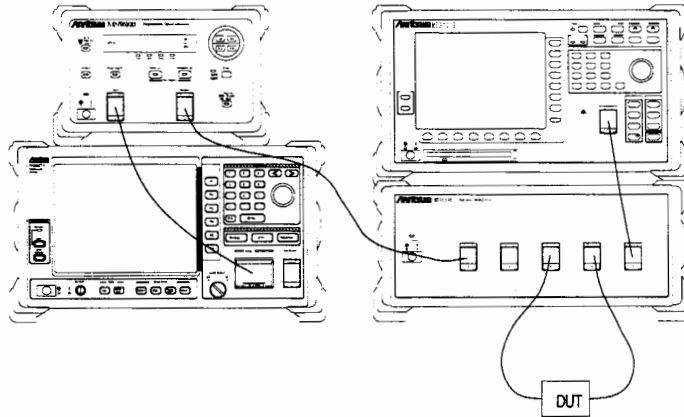

After connection is completed, lower the [Address/Condition] toggle switch and proceed to the measurement condition setting.

CAUTION

Before exiting the [Device Address Setup] panel, the types and the GPIB address of each connected device are checked. If the setting is different from the actual system configuration, a dialog box indicating an error is displayed. In this case, click the [retry] button and set again. To read the stored data without connecting the measuring instruments, click the [Data Recall] button.

7.1.4 Setting the Measurement Conditions

Set the measurement conditions such as the measurement wavelength range on the [Measurement Condition Setup] panel collectively.

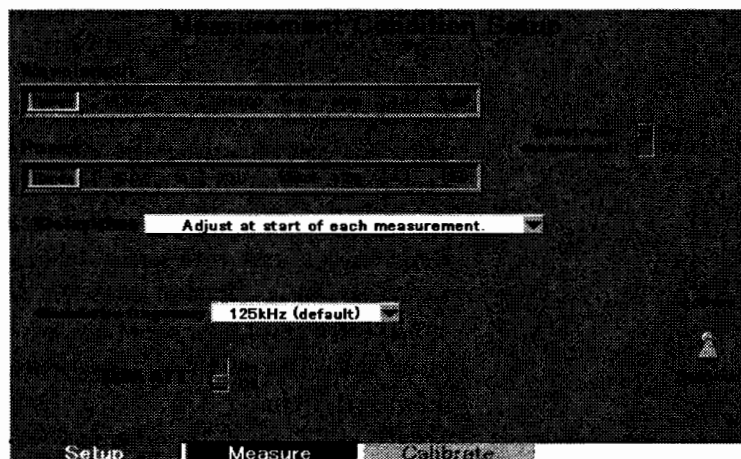

In the [Wavelength] box, specify the wavelength to be measured (input light wavelength). The push-button at the left of the box is the Range/Fix switching button. To make a measurement while changing the wavelength, set to [Range]. To make a measurement with a fixed wavelength, set to [Fix]. If [Range] is set, set the wavelength range and wavelength intervals with the right buttons. If [Another Signal] is selected in Light Source in the [Device Address Setup] panel, enter the number of times of measurement (with changed wavelength) instead of setting the wavelength.

7



In the [Power] box, set the input light power. The push-button at the left of the box is the Range/Fix switching button. To make a measurement while changing the power, set to [Range]. To make a measurement with a fixed wavelength, set to [Fix]. If [Range] is set, set the power range and intervals with the right buttons. If [Another Signal] is selected in Light Source in the [Device Address Setup] panel and [None] is selected in Optical ATT, enter the number of times of measurement (with changed power).



The [Spectrum measurement] switch at the right of the panel is used to set whether to make a spectrum measurement at the time of measurement. If [OFF] is set, the measurement time can be shortened.

In the [Delay time] list, specify when the delay time setting is made. [Delay time] is specified for compensating for the delay time caused by the optical amplifier when measuring the ASE level.

14.3 Delay Time

If [Adjust at start of each measurement] is selected, [Delay time] is adjusted before the start of measurement every time. If [Adjustment only at first measurement] is selected, [Delay time] is adjusted only before the initial measurement and the [Delay time compensation value] in the previous measurement is used in the second and later measurement instead of adjusting the [Delay time]. If [Use previous value] is selected, the [Delay time compensation value] in the previous measurement is used.

In the [Modulation frequency] list, select the modulation frequency. The default is [125 kHz].

The [OSA ATT] switch is used to set ON/OFF of the optical attenuator of the MS9710C optical spectrum analyzer. If the power input to the MS9710C optical spectrum analyzer is larger than 10 dBm, set the switch to ON.

After the entry of the measurement conditions is completed, click the [Measure] card to proceed to the measurement panel.

7.2 Measurement

If the [Start Measure] button is clicked, measurement starts.

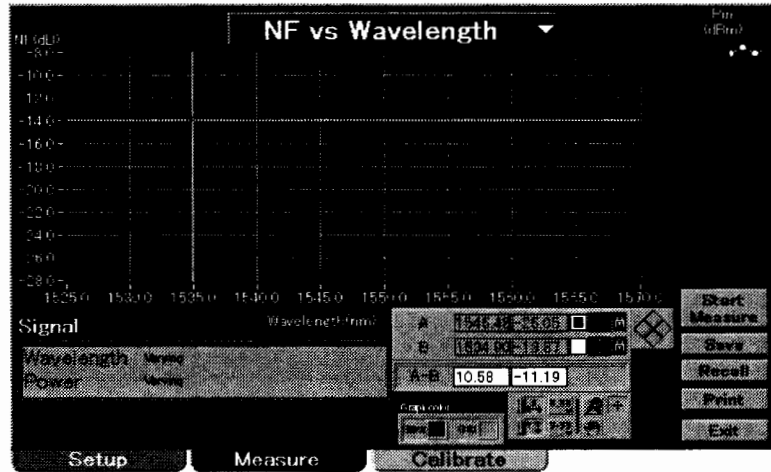

If an option other than [Another Signal] is selected in Light Source in the [Device Address Setup] panel, all measurements are made automatically.

7

If too large power or too small power is entered into the [Power] box in the [Measurement Condition Setup] panel, the following error display is shown.

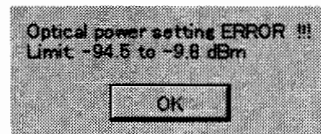

The error display includes the range of valid power. Enter an appropriate power value into the [Power] box in the [Measurement Condition Setup] panel again.

If [Another Signal] is selected in Light Source in the [Device Address Setup] panel, the following wavelength setting dialog box is displayed at the wavelength setting step.

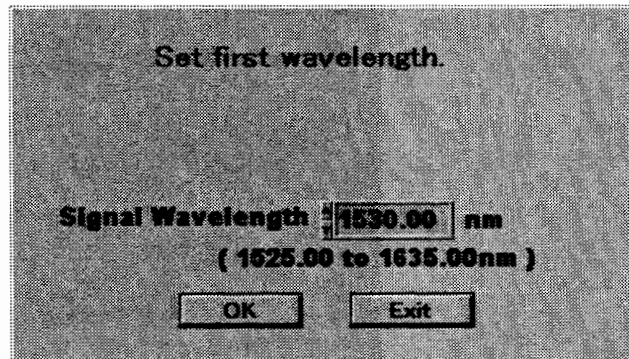

Enter the wavelength of the input light into the dialog box and click the [OK] button.

If [None] is selected in Optical ATT, the following wavelength setting dialog box is displayed at the power setting step.

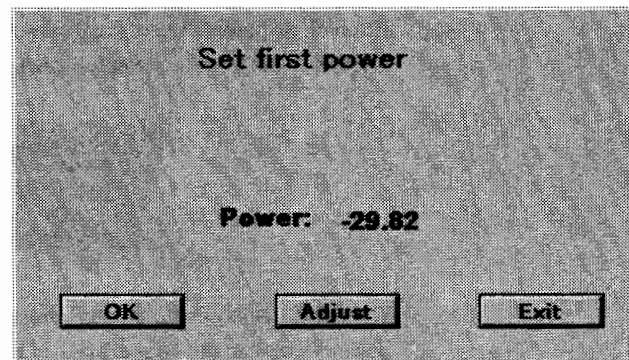

If the power displayed in the dialog box is correct, click the [OK] button.
If the [Adjust] button is clicked, a continual measurement of power is made.
Click the [OK] button at the desired power while changing the attenuation of the optical attenuator and proceed to the next step.
Continue measurements in accordance with the instructions on the screen.

7.3 Displaying Measured Results

The measured results are displayed as a graph.

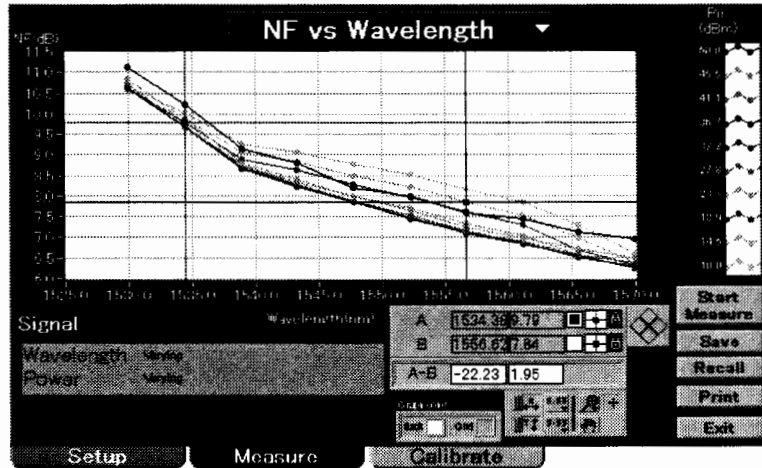

To change the graph type, click the menu list at the top of the graph and select the desired item from the list.

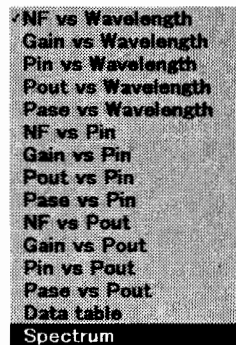

[Spectrum] in the list is valid only when a measurement is made with the [Spectrum Measurement] switch on the [Measurement Condition Setup] panel set to ON.

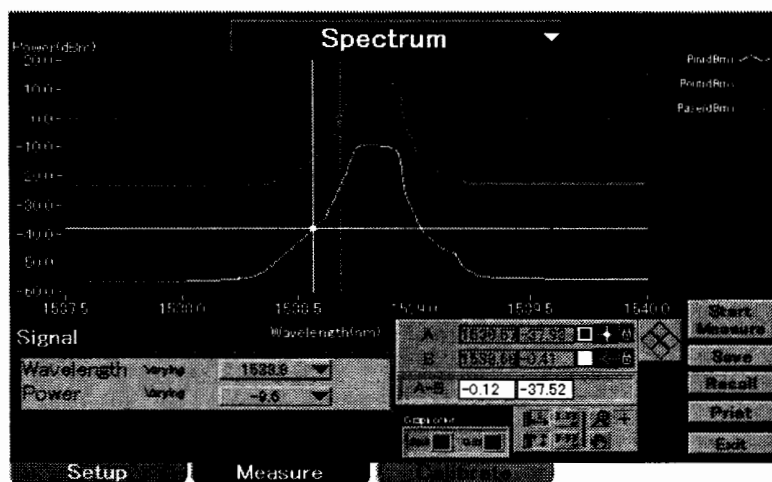



When the spectrum display is selected, the wavelength and power of the input light are displayed in the [Signal] box at the lower left of the graph. If the ▼ mark in the list box is clicked, the wavelength and power can be selected.

7.4 Printing

To output the measured results to the printer, click the [Print] button.

The background, grid, and plot colors of the graph are reflected on the printer output result. If the printer output result is hard to see, change the colors and print it again.

 11.4 Changing Background and Grid Colors

 11.6 Plot Style

CAUTION

To output the measured results to the printer, the printer needs to be connected to the personal computer and enabled by the Windows application program.

7.5 Saving and Recalling Measured Results

The measured data can be saved in the hard disk of the personal computer. If the [Save] button is clicked, the file dialog box appears. Select the drive and directory in which the data is to be saved, enter a file name, and click the [Save (S)] button. The extension [.dat] is attached to the file name. After the data is saved, a dialog box asking whether to create a text file appears.

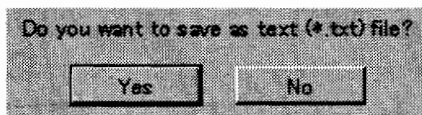

To create a text file, click [Yes], specify the file name, and click the [Save (S)] button. The extension [.txt] is attached to the file name in the text format. To recall the stored data, click the [Recall] button. After the file dialog box appears, select the file name to be recalled and click the [Open (O)] button.

CAUTION

The file saved in the text format cannot be recalled.

In the saved data, the display setting, measurement setting, and device setting (light source type and GPIB address), as well as the measured results are saved. If the setting of the device of the recalled file is different from the setting before recalling, the following warning is displayed.

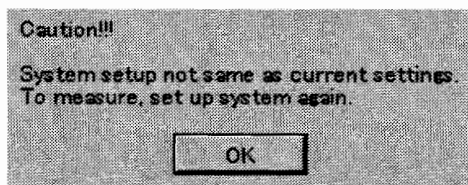

To perform a measurement or calibration, click the [Setup] card and set the system again.

Section 8 Probe Method Measurement Mode

This section describes the measurement method in the probe method measurement mode and other detailed information. In the probe method measurement mode, a wide wavelength range is measured in a short period using saturating signals for saturating the optical amplifier and probe signals for measuring the NF and gain.

To ensure the accuracy of the measured results, be sure to perform calibration before making a measurement. For details on calibration, see “Section 9 Calibration.”

8.1	Setup.....	8-2
8.1.1	Connecting GPIB and RS-232C Cables.....	8-2
8.1.2	System Setting.....	8-3
8.1.3	Connecting Optical Fiber Cords.....	8-4
8.1.4	Setting the Measurement Conditions.....	8-7
8.2	Measurement	8-9
8.3	Displaying Measured Results.....	8-13
8.4	Power Monitor	8-16
8.5	Printing.....	8-19
8.6	Saving and Recalling Measurements.....	8-20
8.7	Adjusting Probe Optical Power.....	8-21
8.8	Determining Saturating Signal Light.....	8-23

8.1 Setup

8.1.1 Connecting GPIB and RS-232C Cables

Connect the MF9619C, the MS9710C, the tunable laser source, the programmable optical attenuator, and the personal computer with GPIB cables. If the MG9637A or MG9638A is used as a probe light source, connect the MS9710C to the personal computer with an RS-232C cable.

Set the GPIB address of the MN9610/11B programmable optical attenuator with the dip switch assembly on the rear side after turning off the power. (For details, see the operation manual of the MN9610/11B programmable optical attenuator.)

The cable connection in the standard system configuration is shown below.

8.1.2 System Setting

Turn on the power of each device and set the GPIB address in accordance with the setup instruction in “Section 4 Setting Up the System.”

Next, start the system software. After setting the [Measurement Method] switch on the start panel to [Probe method] and set the [Language] switch to [English], click the [OK] button. The device address setting screen will appear.

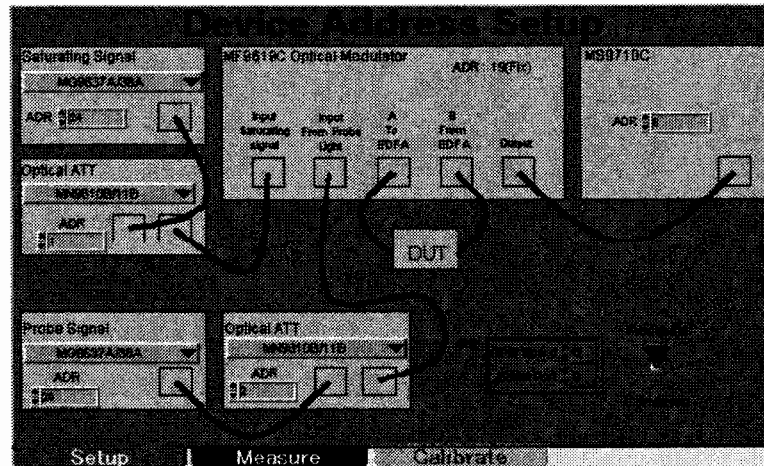

In the [Saturating Signal] list box, select the type of the saturating signal light. Users who employ the MX789000B option 01 can also use the HP8168D/E/F. If another tunable laser source, fixed wavelength light source, or the WDM light source is to be used, select [Another Signal]. In this case, control by GPIB is not performed.

In the [Optical ATT] list box, select the type of the optical attenuator. Users who employ the MX789000B option 01 can also use the HP8156A. If another optical attenuator is used or if an optical attenuator is not used, select [None]. In this case, control by GPIB is not performed.

In the [Probe Signal] list box, select the type of the probe signal light. Either the MG9637A/MG9638A tunable laser source or the optional SLD light source of the MS9710C can be used. If [Another Probe Signal] is selected, other wide-band laser source can be used.

In the [ADR] box, enter the address of each device. The GPIB address of the MF9619C is fixed to 19. For the GPIB address setting method of other devices, see the operation manual of each device. Set the GPIB address in the range 1 to 30. Do not set the same address to different devices.

In the [PC] box, enter the GPIB board number (normally 0) and the serial port number (normally 0) of the personal computer.

8.1.3 Connecting Optical Fiber Cords

In accordance with the display on the [Device Address Setup], connect optical fiber cords. The connection diagram of optical fiber cords in the standard system configuration is shown below.

The connection diagram of optical fiber cords in the case of using the MS9710C optional SLD light source as a probe light source is shown below. To the optical connector port under the MS9710C, an optical fiber cord is connected from the SLD light source output port on the rear side of the MS9710C.

After connection is completed, lower the [Address/Condition] toggle switch and proceed to the measurement condition setting.

CAUTION

Before exiting the [Device Address Setup] panel, the type and the GPIB address of each connected device are checked. If the setting is different from the actual system configuration, a dialog box indicating an error is displayed. In this case, click the [retry] button and set again. To read the stored data without connecting the measuring instruments, click the [Data Recall] button.

8.1.4 Setting the Measurement Conditions

Set the measurement conditions such as the wavelength range on the following [Measurement Condition Setup] panel.

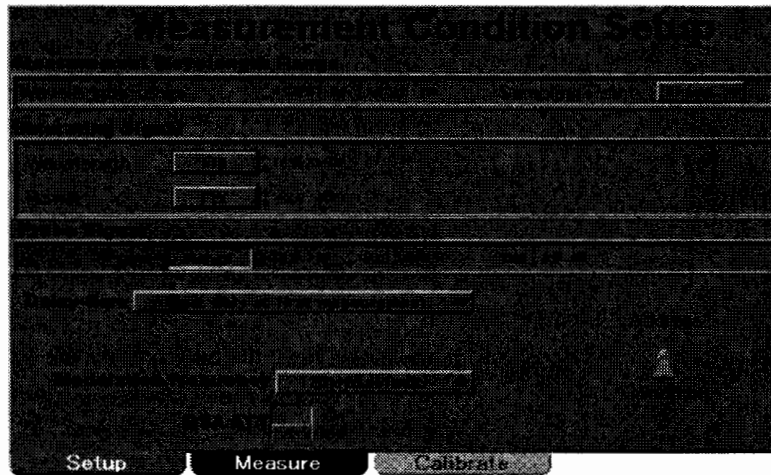

In the [Measurement Wavelength Range] box, specify the measurement wavelength range and the number of sampling points.

In the [Saturating Signal] box, specify the wavelength and power of the saturating signal light. The [Fix] (or [Range]) button is used to specify whether the parameter is to be fixed or variable. To set the parameter to be variable, select [Range] and enter the range and interval. If the type of saturating signal power is set to [Another Signal], enter the number of times of measurement (with changed wavelength or power).

In the [Probe Signal] box, specify the power of the probe light. The [Fix] (or [Range]) button is used to set whether the probe light power is to be fixed or variable. To set the probe power light to be variable, select [Range] and enter the range and interval. If the type of optical attenuator of probe signal light is set to [None], enter the number of times of measurement (with changed power). Note that [Range] cannot be set for two or more items simultaneously.

If a light source other than the MG9637A/38A is specified as the probe signal light source, the Total/Point button is displayed at the left of the [Probe Signal] box.

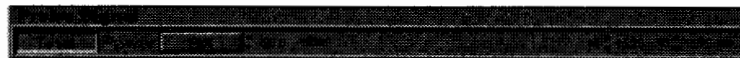

This button is used to specify the method of power setting. For the wide-band power source such as SLD light source, there are two power-setting methods: the method of specifying the total power (integral power) within a certain wavelength range and the method of specifying the power per unit nm in a certain wavelength. To specify the power as a total power, set the Total/Point button to Total and enter the wavelength range (integral range) into the region at the left end of the box. To specify the power as a power per unit nm, set the Total/Point button to Point and enter the wavelength into the region at the left end of the box.



In the [Delay time] list, specify when the delay time setting is made. [Delay time] is specified for compensating for the delay time caused by the optical amplifier when measuring the ASE level.

14.3 Delay Time

If [Adjust at start of each measurement] is selected, [Delay time] is adjusted before the start of measurement every time. If [Adjust only at first measurement] is selected, [Delay time] is adjusted only before the initial measurement and the [Delay time compensation value] in the previous measurement is used in the second and later measurement instead of adjusting the [Delay time]. If [Use previous value] is selected, the [Delay time compensation value] in the previous measurement is used.

In the [Modulation frequency] list, select the modulation frequency. The default is [125 kHz].

The [OSA ATT] switch is used to set ON/OFF of the optical attenuator of the MS9710C optical spectrum analyzer. If the power input to the MS9710C optical spectrum analyzer is larger than 10 dBm, set the switch to ON.

After the entry of the measurement conditions is completed, click the [Measure] card to proceed to the measurement panel.

8.2 Measurement

If the [Start Measure] button is clicked, measurement starts.

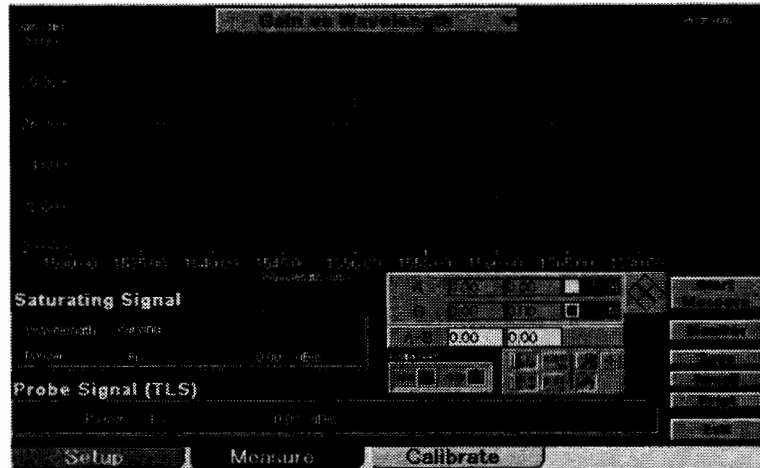

If an option other than [Another Signal] is selected as the type of saturating signal source and an option other than [None] is selected as the type of optical attenuator of probe signal light (or the MG9637A/38A is set as the type of probe signal light), all measurements are made automatically.

If too large power or too small power is set, the following error display is shown.

8

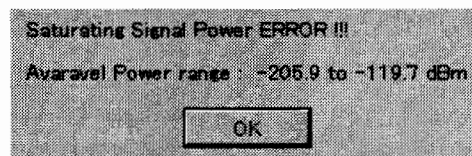

The error display includes the range of valid power. Enter an appropriate power into the [Power] box in the [Measurement Condition Setup] panel again.

If the type of saturating signal light is set to [Another Signal] and the type of optical attenuator is set to [None], the following wavelength setting dialog box is displayed at the step of setting the output of saturating signal light to ON or OFF.

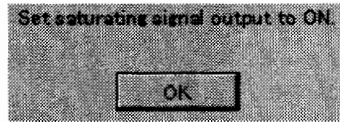

Set the output of the saturating signal light to ON or OFF in accordance with the instruction of the dialog box. Clicking the [OK] button leads to the next step.

If the type of saturating signal light is set to [Another Signal], the following channel selection dialog box is displayed at the step of setting the wavelength and power of the saturating signal light. Select the input saturating signal light here. Since it also supports the WDM signal lights, multiple channels can be selected.

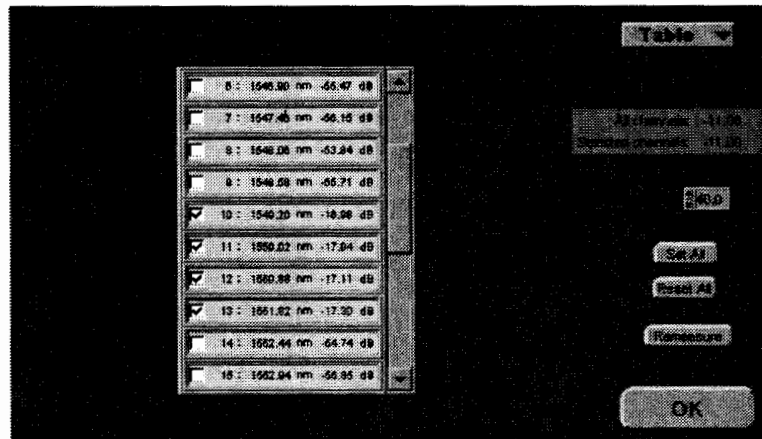

By putting a check mark in the check box at the left end by clicking the mouse over it, the channel is selected.

If the ▼ in the menu list at the upper right of the dialog box is clicked, the display can be changed into the graph display format.

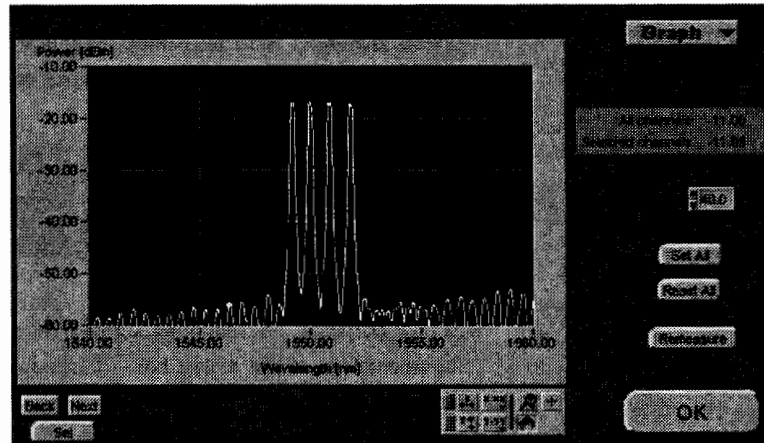

The wavelength indicated with a yellow circle is the presently selected wavelength. If the marker movement button  at the lower right of the graph is pressed, the selected wavelength can be moved by drawing the mouse. The selected wavelength can also be moved by clicking the Next/Back button. If the [Set] button is clicked, the selected wavelength is set and the button name is switched to [Reset]. If the [Reset] button is clicked, the selected wavelength is canceled. Select one or more wavelengths and click the [OK] button.

To change the saturating signal light wavelength, change wavelength before clicking the [OK] button, click the [Remeasure] button, select the channel again, and then click the [OK] button.

If [None] is selected as the type of optical attenuator, the saturating signal light power can be checked from the channel selection dialog box. In the field under [Total Power] on the right side of the screen, the total power of the selected channels is displayed. To change the power, change power before clicking the [OK] button, click the [Remeasure] button, select the channel again, and then click the [OK] button. If an option other than [None] is selected in the type of optical attenuator, the power is set automatically by controlling the optical attenuator.

If the type of probe signal light is set to [Another Probe Signal] and the type of optical attenuator is set to [None], the following wavelength setting dialog box is displayed at the step of setting the output of probe signal light to ON or OFF.

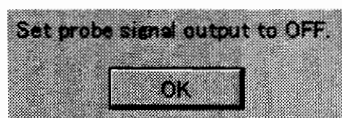

Set the output of the saturating signal light to ON or OFF in accordance with the instruction of the dialog box. Clicking the [OK] button proceeds to the next step.

If the type of probe signal light is set to other than [MG9637A/38A] and the type of optical attenuator is set to [None], the following channel selection dialog box is displayed at the step of setting the output power of the probe signal light.

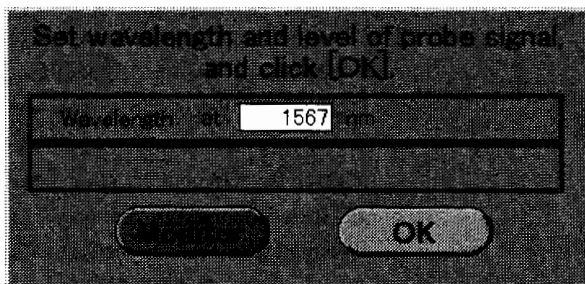

To change the probe signal light power, click the [Monitor] button and measure the probe light power continuously. Adjust the probe light power while seeing the monitor output and click the [OK] button when the desired value is obtained.

8.3 Displaying Measured Results

The measured results are displayed as a graph. The following is an example of a graph measured while changing the probe light power.

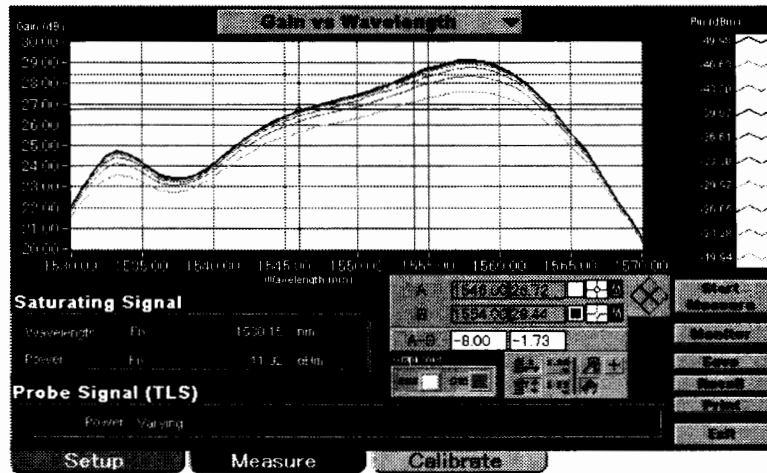

The graph type can be selected from the menu list at the top of the graph.

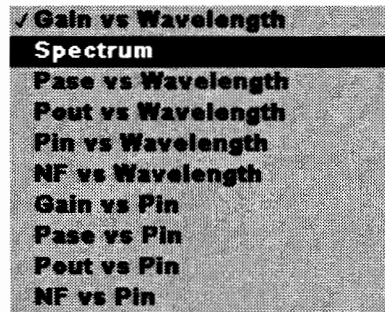

8

The types of graphs that can be displayed differ depending on which parameter is set to [Range].

In the [Saturating Signal] box under the graph, the saturating signal light measured results are displayed. If the WDM light source is used and [Another Signal] is set as the type of saturating signal light for measurement, the average wavelength and the total power of the selected channels are displayed.

In the probe method, Pin is the input probe light power and Pout is the amplified probe light power. The following is an example of spectrum display measured while changing the probe light power.

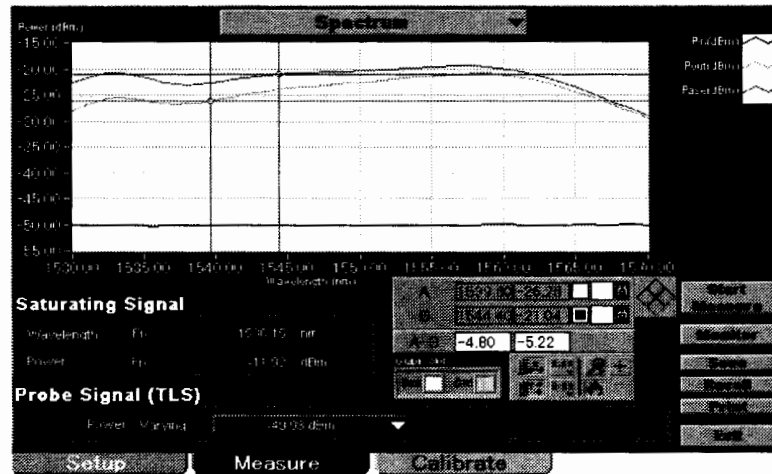

In the [Probe Signal] box, the power of the probe signal light is displayed. If the ▼ mark in the box is clicked and the level is selected, the spectrum at the measurement with the probe signal power is displayed.

The following is a display example of Gain vs. Pin.

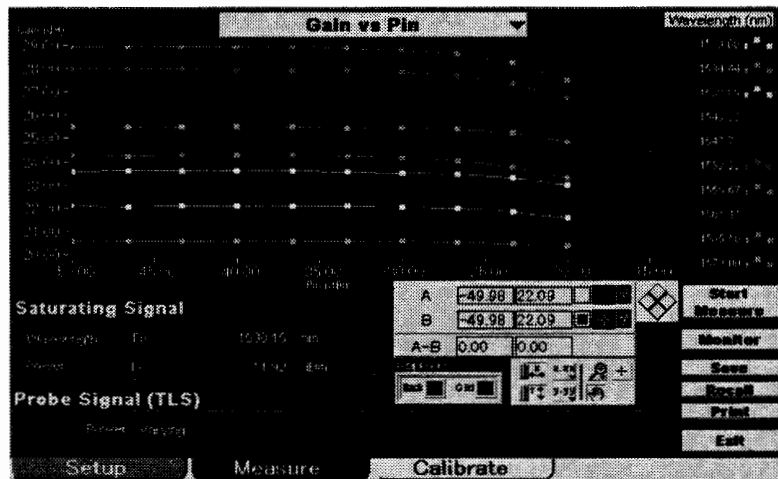

If the wavelength is set as a parameter as shown in this example, the [Wavelength (nm)] button is displayed at the upper right of the display. To change the wavelength to be displayed, click this button.

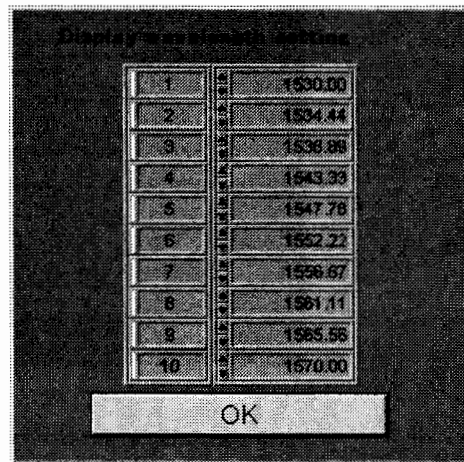

8

The display wavelength setting dialog is displayed. Enter the wavelength to be displayed and click the [OK] button.

8.4 Power Monitor

The power monitor is used to measure the optical amplifier input light power (saturating signal light power) or optical amplifier output light power continuously and display the wavelength and power of each channel and the total power.

If the [Monitor] button is clicked, the dialog for selecting the input light power (Pin) or the output light power (Pout) is displayed.

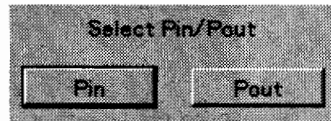

Click the Pin or Pout button. After a spectrum measurement is made, the channel selection panel is displayed. Select which channel (wavelength) to monitor on this panel.

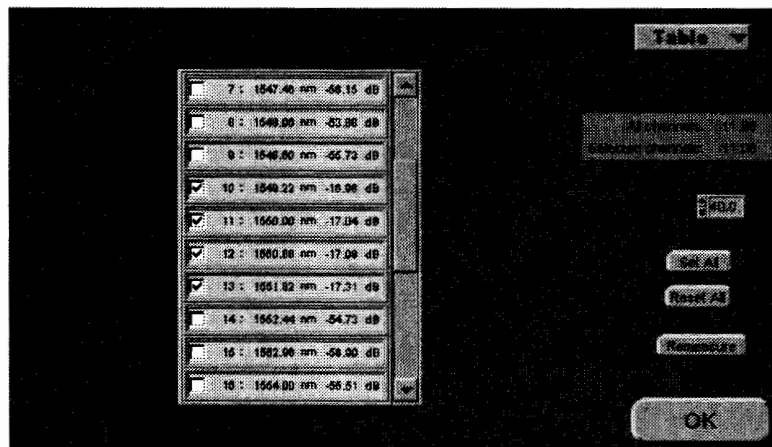

Put a check mark in the check box at the left side of the wavelength to be monitored by clicking the mouse over the check box. With the scroll bar on the right side of the table, the hidden channels can be displayed. If the ▼ mark on the Table list box is clicked and [Graph] is selected, the screen is switched to the graph display screen.

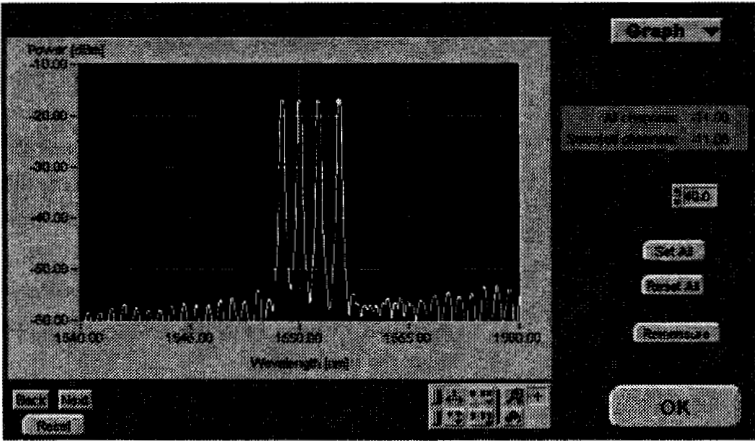

The wavelength indicated with a yellow circle is the present marker location. If the marker movement button  at the lower right of the graph is pressed, the marker can be moved by drawing the mouse. The marker can also be moved by clicking the Next/Back button. If the [Set] button is clicked, the channel at the marker location is selected and the button name is switched to [Reset]. If the [Reset] button is clicked, the selected marker is canceled. Select one or more wavelengths and click the [OK] button. The monitor panel will appear.

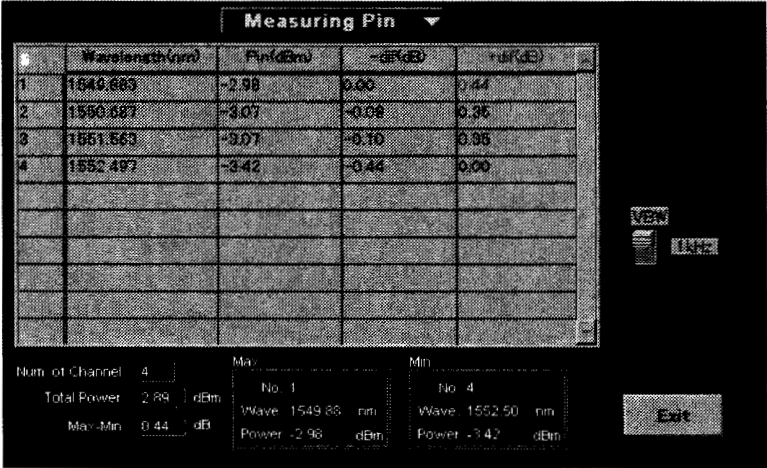

	Wavelength(nm)	Pin(dBm)	-dB(dB)	+dB(dB)
1	1546.685	-2.98	0.00	0.44
2	1550.687	-3.07	-0.08	0.36
3	1551.563	-3.07	-0.70	0.36
4	1552.497	-3.42	-0.44	0.00

Num. of Channel: 4
Total Power: 2.89 dBm
Max-Min: 0.44 dB

Max: No. 1
Wave: 1549.86 nm
Power: -2.98 dBm

Min: No. 4
Wave: 1552.50 nm
Power: -3.42 dBm

Buttons: [VIEW], [INFO], [Exit]

8

The wavelength and power in each channel are displayed in the table format. In the [(dif] column, the difference in power between the selected channel and the channel having the maximum power is displayed. In the [+dif] column, the difference in power between the selected channel and the channel having the minimum power is displayed. Under the table, the number of channels, the sum total of powers of these channels, the difference between the maximum and minimum power, and the maximum (minimum) channel information are displayed.

By clicking the ▼ mark in the list box at the upper portion of the table and selecting Pout (or Pin), the screen can be switched to the monitor of the output light (or input light).

The measuring speed can be changed with the VBW switch on the right side of the table. If 1 kHz is selected, a high-speed measurement is made. If it is set to 100 Hz, a high accuracy measurement is made.

To exit the monitor, click the [Exit] button.

8.5 Printing

To output the measured results to the printer, click the [Print] button.

The background, grid, and plot colors of the graph are reflected on the printer output result. If the printer output result is hard to see, change the colors and print it again.

 11.4 Changing Background and Grid Colors

 11.6 Plot Style

CAUTION

To output the measured results to the printer, the printer needs to be connected to the personal computer and enabled by the Windows application program.

8.6 Saving and Recalling Measurements

The measured data can be saved in the hard disk of the personal computer. If the [Save] button is clicked, the file dialog box appears. Select the drive and directory in which the data is to be saved, enter a file name, and click the [Save (S)] button. The extension [.dat] is attached to the file name. After the data is saved, a dialog box asking whether to create a text file appears.

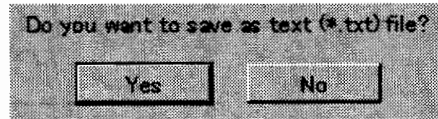

To create a text file, click [Yes], specify the file name, and click the [Save (S)] button. The extension [.txt] is attached to the file name in the text format. To recall the stored data, click the [Recall] button. After the file dialog box appears, select the file name to be recalled and click the [Open (O)] button.

CAUTION

The file stored in the text format cannot be recalled.

In the saved data, the display setting, measurement setting, and device setting (light source type and GPIB address), as well as the measured results are saved. If the setting of the device of the recalled file is different from the setting before recalling, the following warning is displayed.

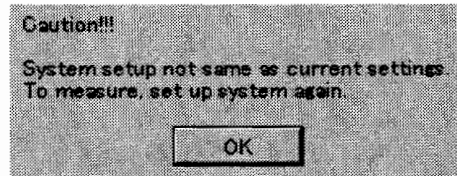

To perform measurement or calibration, click the [Setup] card and set the system again.

8.7 Adjusting Probe Optical Power

A probe method measurement is made based on the premise that probe light power small enough not to affect the locked inversion state of the optical amplifier is used. If the probe light power is too small, however, noises have adverse effect on the measurement accuracy. Therefore, determining the probe light power is very important.

To determine the probe light power, it is necessary to make a measurement while changing the probe light power and determine the probe light power used for measurement from the measured results. In the following example, the probe light power and the gain are plotted in the horizontal and vertical axes, respectively, with the MG9637A tunable laser source as a probe light and by making a measurement while changing the probe light power (Pin) from -50 dBm to -20 dBm.



8

The curve in the center of the graph is a characteristic in a wavelength of 1547.78 nm. The graph indicates that the gain measurement results are distorted due to the influence of the probe light power on the optical amplifier in the region over -30 dBm. The graph also indicates that the measured results agree with an accuracy of 0.1 dB in the region below -30 dBm. In this example, an accurate measurement can be made by setting the probe power to around -40 dBm.

As described above, determine the probe power using the result of measurement made by changing the probe light power actually.

CAUTION

The influence of the probe light power on the optical amplifier differs depending on the characteristics of the optical amplifier, as well as the wavelength and power of the saturated signal light. It is recommended that appropriate probe light power be measured again if any of the above conditions is changed.

If a wide-band laser source such as an SLD light source is used as a probe light, the range of the probe light power that satisfies the conditions "The probe light power has little influence on the optical amplifier and noises have little influence on measurement" is very narrow. In some cases, there is no region that satisfies both conditions.

From the spectrum wavelength, the degree of noises can be estimated.

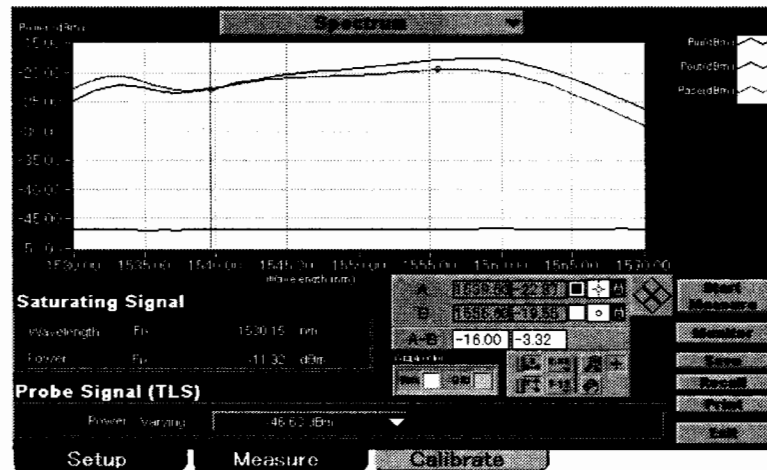

Pout indicates the probe light power after amplification. Pout can be measured by subtracting the spectrum without the input of the probe light (Pase: spontaneous emission light power only) from the output spectrum with the input of the probe light (Pout: probe light power after amplification +Pase: spontaneous emission light power). Therefore, if the probe power after amplification Pout is smaller than the spontaneous emission light power Pase, the error becomes large. In the spectrum display, the relation between Pout and Pase can be checked at a glance. In the above example, it is estimated that there are large noise in a wavelength region of 1540 nm or less in which Pout is smaller than Pase.

8.8 Determining Saturating Signal Light

The optical amplifier for WDM can be tested by replacing the actually used WDM light source with one or several saturating signal sources. In this case, determine the number, wavelength, and power of saturating signal lights by comparing to the value measured in the normal mode.

First, measure the NF/gain in the normal mode using the WDM light source to be used actually. For details of measurement, see Section 6. The measured results are the standard value (the most reliable value) of the NF/Gain.

 Section 6 Normal Measurement Mode

Next, make a measurement in the probe method measurement mode after reducing the number of WDM light sources and check whether the measured results agree with those measured in the normal mode. If they do not agree, make a measurement again after increasing the number of saturating signal lights, changing the wavelength, or changing the power and compare the measured results with those in the normal mode.

By repeating the above operation, determine the number, wavelength, and power of saturating signal lights.

In the following method, for example, two channels of WDM signals are considered as one pair and the pair is replaced with one saturating signal light.

- Set the wavelength to the center wavelength of two channels.
- Set the power to the total power of two channels.

Reduce the number of saturating signal powers by repeating the above operations.

Once the saturating signal light is determined in the above method, an optical amplifier having the similar characteristics can be measured in the same measurement conditions.

Section 9 Calibration

This section describes calibration. Calibration is an operation of measuring the insertion loss of the MF9619C optical modulator and creating data for correcting the measured results. To make a measurement accurately, it is necessary to perform level calibration of the MS9710C optical spectrum analyzer. For details, see “Section 10 To Make Highly Accurate Measurement.”

- 9.1 Calibration 9-2
- 9.2 Checking Calibration Data..... 9-6

9.1 Calibration

Perform calibration before starting measurement. Particularly, be sure to perform calibration before performing measurement for the first time. Besides, perform calibration when the environmental conditions is changed (e.g., change of three or more degrees in temperature) or after several hours have elapsed.

Calibration is an operation of measuring the insertion loss of the MF9619C using spontaneous emission light of the optical amplifier and creating data for correcting the measured results.

As a light source for calibration, use spontaneous emission light from the optical amplifier to be measured. The light output from the optical amplifier in states where no signal light is input shows level wavelength characteristics and the wavelength and loss characteristics can be measured in a short period.

For calibrating this system, the output level of spontaneous emitted light should be greater than -50dBm for each wavelength.

(This result is obtained from the measurements of spontaneous emitted light spectrum for calibrating the system by setting the resolution of MS9710C set to 0.2 nm.)

The calibration of this system is performed in the entire measurable wavelength range (1525 to 1635 nm) using an inputted optical level. Therefore, the calibration for band L cannot be performed accurately if spontaneous emitted light of the Optical Amplifier for the band C is used for performing calibration. (It is because of the low output level)

Hence, perform the calibration by following any one of the methods below.

- Perform the calibration each time when the wavelength range to be measured and tested is changed.
- Combine both spontaneous emitted lights using optical coupler, and perform the calibration with the outputted light.

Calibration can be performed from any measurement mode. If the [Calibrate] card is clicked on the measurement panel, the calibration start panel appears.

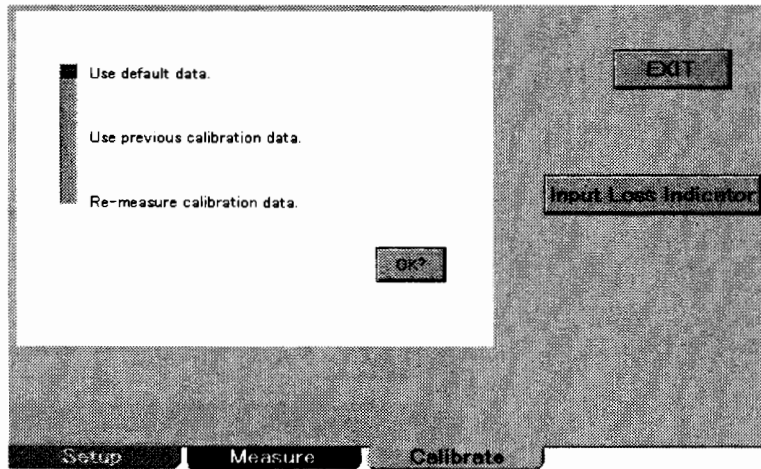

To start calibration, place the slide switch on the left side of the panel at [Re-measure calibration data] and click the [OK] button.

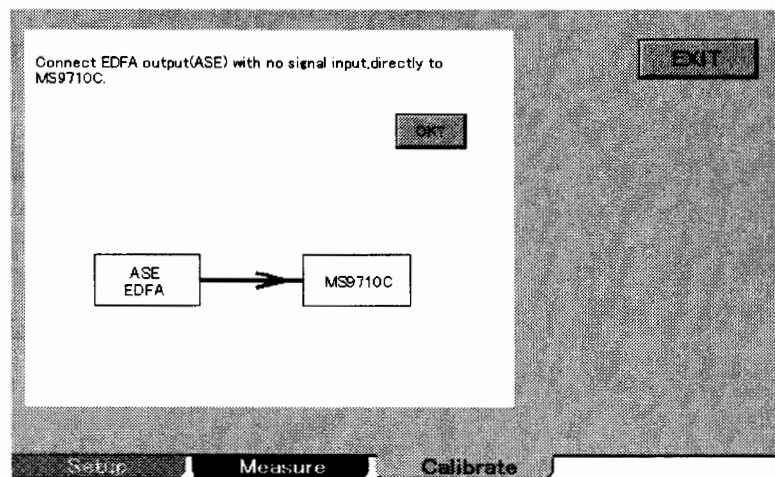

9

In accordance with the instructions on the panel, input the light output from the optical amplifier to be measured into the MS9710C optical spectrum analyzer directly using an optical fiber cord. Do not connect anything to the input port of the optical amplifier. After connection is completed, click the [OK] button. In this operation, the power of the reference light (reference power) is measured. After the measurement is completed, the next panel appears.

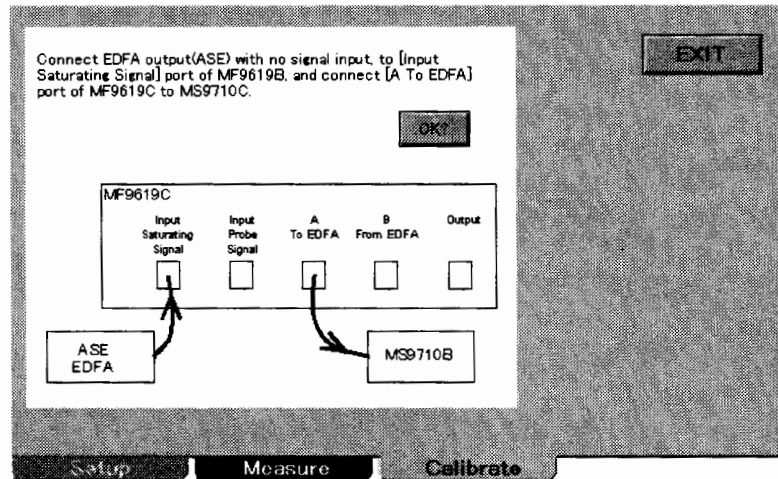

In accordance with the instructions on the panel, connect the light output from the optical amplifier to the [Input Saturating Signal] port and connect the [A To EDFA] port and the MS9710C using an optical fiber cord. After connection is completed, click the [OK] button.

In the same way, continue calibration while changing the optical fiber cord in accordance with the instructions on the panel.

HINT

Change only one of the two optical fiber cords.

After calibration is completed, the following panel is displayed.

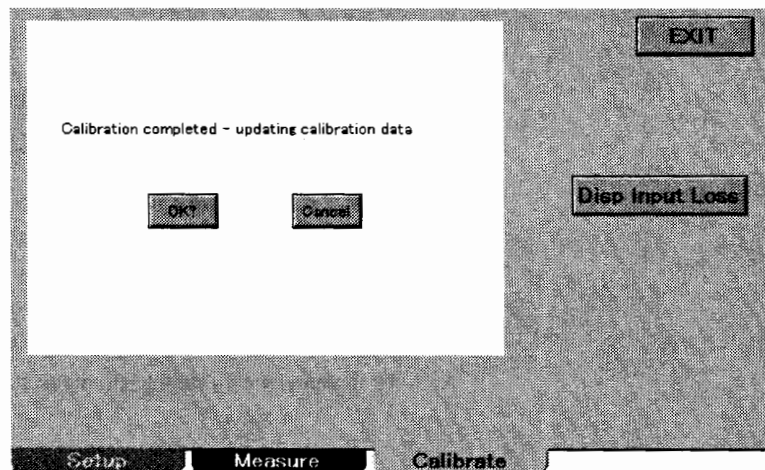

Click the [OK?] button to end calibration.

The connection of the two optical fiber cords at the end of calibration are the same as the connection used to make an measurement. Connect the other unconnected optical fiber cords in accordance with the description in each section of measurement.

CAUTION

If calibration is performed in a mode other than the probe method measurement mode, [Input Probe Signal] port is not calibrated. The data in this portion remains unchanged from the previous calibration. Since the calibration data in this portion is not required unless a measurement is made in the probe method measurement mode, no problem occurs. However, if calibration is performed in a mode other than the probe method measurement mode and a measurement is made in the probe method measurement mode, a problem occurs. When making a probe method measurement, perform calibration in the probe method measurement mode.

9.2 Checking Calibration Data

If the [Disp Input Loss] button on the calibration panel is clicked, calibration data can be checked. In the course of calibration or at the completion of calibration, calibration data can be checked if the [Disp Input Loss] button is displayed.

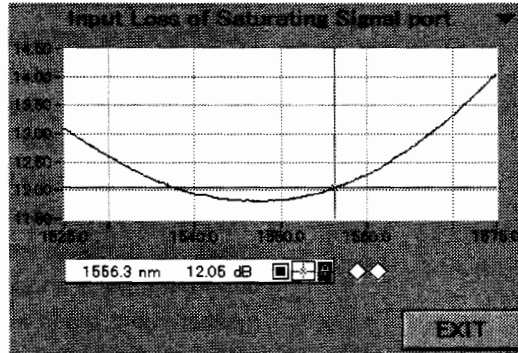

The displayed data is the wavelength and the insertion loss between the [Input Saturating Signal] port and the [A To EDFA] port. In the probe method measurement mode, this data can be utilized as a standard value for the adjustment of the saturating signal light power in the probe method measurement mode and a standard value for the adjustment of the input signal light power in a mode other than the probe method measurement mode.

The vertical axis of the graph indicates the loss and the unit is dB, while the horizontal axis is the wavelength and the unit is nm. Under the graph, the wavelength and loss at the marker location are displayed. The marker location can be moved by drawing the mouse.

If entering the calibration panel from the probe method measurement mode, it is also possible to check the wavelength and the loss characteristics between the [Input Probe Signal] port and the [A To EDFA] port. Click the ▼ mark, and then click [Input Loss of Probe Signal port] from the list.

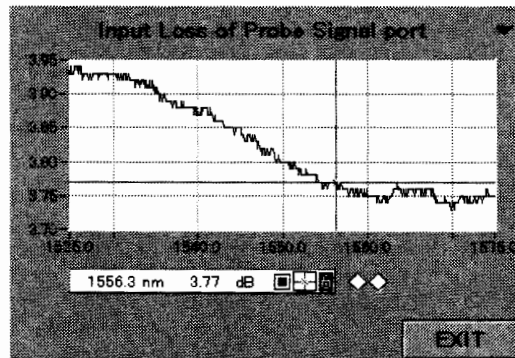

It can be used to examine the range of probe light power that can be input in the probe method measurement mode.

If the [Exit] button is clicked, graph display is canceled and the calibration panel appears.

CAUTION 

The insertion loss differs significantly between the MF9619C standard type and option 01SLD type. See the product specifications after checking the type used.

9-8.

Section 10 To Make Highly Accurate Measurement

In the normal mode or the tunable laser interlock measurement mode, measurements are made in the highly accurate optical pulse method. This section describes the method of measuring the NF value in the optical pulse method accurately. Section 10.1 describes the measurement errors of the NF measurement. Sections 10.2 and 10.3 describe the calibration method required for making highly accurate measurements.

10.1 Error Factors	10-2
10.1.1 Analyzing Error Factors	10-2
10.1.2 Measurement Error of Pase:	
$\Delta\text{Pase}/\text{Pase}$	10-3
10.1.3 Measurement Error of Gain:	
$\Delta\text{G}/\text{G}$	10-4
10.1.4 Resolution Accuracy Error:	
$\Delta\text{Res}/\text{Res}$	10-5
10.1.5 Measured Wavelength Error:	
$\Delta\lambda/\lambda$	10-5
10.1.6 Total Error	10-5
10.2 Level Accuracy Correction	
of Optical Spectrum Analyzer	10-6
10.2.1 Optical Power Measurement	
in Reference Level	10-6
10.2.2 Optical Axis Adjustment	10-6
10.2.3 Level Offset Adjustment	10-6
10.3 System Calibration	10-7

10.1 Error Factors

10.1.1 Analyzing Error Factors

In this system, the measurement accuracy of the noise figure (NF) of the optical amplifier using the optical pulse method is guaranteed by regulating measurement errors of the required measurement items individually. To make highly accurate measurements, it is important to understand the error factors of NF measurement in this system. In the probe method measurement, the measured results in the optical pulse method are used as the standard value. Therefore, highly accurate measurement in the optical pulse method is very important.

The noise figure (NF) of the optical amplifier can be obtained in the following equation in the optical method using the optical spectrum analyzer.

$$NF = P_{ase} \times \lambda^3 / (h \times c^2 \times Res \times G) + 1 / G$$

Where,

- P_{ase}: ASE power [W]
- λ: Signal light wavelength [m]
- h: Planck's constant [J•s]
- c: Light velocity in vacuum [m/s]
- Res: Resolution width of optical spectrum analyzer [m]
- G: Gain

From the above equation, the statistical error of NF measurement is expressed in the following equation.

$$\Delta NF / NF = \sqrt{(\Delta P_{ase} / P_{ase})^2 + (\Delta G / G)^2 + (\Delta Res / Res)^2 + 3 \cdot (\Delta \lambda / \lambda)^2}$$

Each item is described in the following. The description in each section below is for band C.

10.1.2 Measurement Error of Pase: Δ Pase/Pase

The measurement error factors of Pase include:

- [1] An error caused by the level reproducibility due to connection / disconnection of an optical fiber cord
- [2] An error caused by a level measurement error
- [3] An error caused by the switching reproducibility of the optical switches

- [1] An error caused by the level reproducibility due to connection/ disconnection of an optical fiber cord

Since optical fiber cords are connected and disconnected when performing calibration, an error occurs because the connector connection loss at the time of calibration is different from that in the actual measurement. To make a highly accurate measurement, use the master cord (ordering number: J0846B) of application parts. Since the eccentricity of the core is small in the master cord, the reproducibility of connection loss can be restricted to 0.05 dB or less. Since an optical fiber cord is connected and disconnected three times at the time of calibration, the total level reproducibility is indicated in the following equation.

$$\sqrt{(3 \cdot (0.05 \text{ dB})^2)} = 0.086 \text{ dB}$$

- [2] An error caused by a level measurement error

To make a highly accurate measurement, calibrate the measurement level accuracy of the optical spectrum analyzer using a highly accurate power meter such as the ML9050A standard optical power meter.

When calibration is performed using a power meter with a level accuracy of 2.2 %, the following three level measurement errors must be taken into account.

- The measurement level accuracy 2.2 % of the power meter = 0.095 dB
- The level flatness of the optical spectrum analyzer 0.1 dB
- The level linearity of the optical spectrum analyzer 0.05 dB

Therefore, the total level measurement errors are indicated in the following equation.

$$\sqrt{((0.095 \text{ dB})^2 + (0.1 \text{ dB})^2 + (0.05 \text{ dB})^2)} = 0.146 \text{ dB}$$

- [3] An error caused by the switching reproducibility of the optical switches

The optical switch used in the MF9619C is switched between the calibration time and the measurement time. Since the loss of the optical switch is changed at this time, an error occurs. In the MF9619C, two optical switches with a switching reproducibility of 0.005 dB or less are placed in series. Therefore, the total error due to switching reproducibility are indicated in the following equation.

$$\sqrt{(2 \times (0.005 \text{ dB})^2)} = 0.007 \text{ dB}$$

From items [1] to [3], the measurement error ($\Delta P_{ase}/P_{ase}$) is indicated in the following equation.

$$\Delta P_{ase}/P_{ase} = 0.086 + 0.146 + 0.0007 = 0.239 \text{ dB}$$

Since the ASE in an erbium doped fiber amplifier causes no polarization, an error caused by the polarization dependent characteristics does not occur. (The ASE is also used at the time of calibration.)

10.1.3 Measurement Error of Gain: $\Delta G/G$

The measurement error factors of the gain G include:

- [1] An error caused by level linearity
- [2] An error caused by polarization-dependent characteristics
- [3] An error caused by the switching reproducibility of the optical switches

[1] An error caused by level linearity

The gain G is obtained from the ratio of the light power input to the optical amplifier P_{in} to the amplified light power P_{out} . Therefore, the level linearity of the optical spectrum analyzer 0.05 dB becomes an error factor.

[2] An error caused by polarization dependent characteristics

Since the internal optical switch in the MF9619C is switched, the polarization of light is different between the P_{in} measurement and the P_{out} measurement. Due to the polarization dependent characteristics of the optical switch inside the MF9619C and the optical spectrum analyzer, an error occurs between the ratio of P_{in} to P_{out} . The polarization dependent characteristics of the optical spectrum analyzer is 0.05 dB or less and the polarization dependent characteristics of the optical switch used in the MF9619C is 0.025 dB or less. Since light passes through the optical switch twice when measuring P_{in} and it passes through the optical switch three times when measuring P_{out} , the total error due to polarization dependent characteristics can be obtained in the following equation.

$$\sqrt{(5 \cdot (0.025 \text{ dB})^2 + 2 \cdot (0.05 \text{ dB})^2)} = 0.0896 \text{ dB}$$

For the error caused by the polarization dependent characteristics of the optical modulator used inside the MF9619C, no error occurs because the polarization at the time of P_{in} measurement is equal to that at the time of P_{out} measurement. However, it is necessary to keep the optical fiber cord connected to the Input port of the MF9619C stable so that the polarization of the input light is not changed during measurement.

[3] An error caused by the switching reproducibility of the optical switches

The error caused by the switching reproducibility of the optical switches is 0.005 dB.

From items [1] to [3], the measurement error of the gain ($\Delta G/G$) is indicated in the following equation.

$$\Delta G/G = 0.05 + 0.0896 + 0.005 = 0.145 \text{ dB}$$

10.1.4 Resolution Accuracy Error: $\Delta\text{Res}/\text{Res}$

An error caused by the resolution accuracy of the optical spectrum analyzer. In this system, measurements are made using a resolution of 0.2 nm with a resolution accuracy of 3 %, and the resolution of 0.2 nm is corrected using a resolution of 0.5 nm with a resolution accuracy of 2.2 % (0.1 dB). At this time, the error caused by the linearity of the optical spectrum analyzer 0.05 dB is added. Therefore, the error caused by the resolution accuracy is indicated in the following equation.

$$\Delta\text{Res}/\text{Res} = \sqrt{(0.1 \text{ dB})^2 + (0.05 \text{ dB})^2} = 0.111 \text{ dB}$$

10.1.5 Measured Wavelength Error: $\Delta\lambda/\lambda$

The measurement wavelength error: $\Delta\lambda/\lambda$ of the optical spectrum analyzer after calibrating the wavelength is indicated in the following equation.

$$\Delta\lambda/\lambda = 0.2 \text{ nm} / 1550 \text{ nm} = 0.0006 \text{ dB}$$

10.1.6 Total Error

From Sections 10.1.2 to 10.1.5 above, the total NF measurement error $\Delta\text{NF}/\text{NF}$ is indicated in the following equation.

$$\begin{aligned} \Delta\text{NF} / \text{NF} &= \\ &\sqrt{((0.239 \text{ dB})^2 + (0.145 \text{ dB})^2} \\ &+ (0.111 \text{ dB})^2 + 3 \cdot (0.0006 \text{ dB})^2} \\ &= 0.298 \text{ dB} \end{aligned}$$

10.2 Level Accuracy Correction of Optical Spectrum Analyzer

As described in the previous section, to make an NF measurement with a measurement accuracy of 0.3 dB or less, it is necessary to perform the level correction of the optical spectrum analyzer using a power meter of an accuracy of 2.2 % or less. This section describes the correction method.

10.2.1 Optical Power Measurement in Reference Level

Input a 1.55 μm single mode oscillating power source with a light level of -30 dBm or more into the standard optical power meter and measure the power. As an optical fiber cord, use a master cord (ordering number: J0846B) of application parts. The master cord has two types of connectors: the master connector with small core eccentricity (FAA) and the connector with normal eccentricity (FCA). Connect the connector on the FCA side to the light source and the connector on the FAA side to the power meter, and then measure the power.

10.2.2 Optical Axis Adjustment

Connect the connector on the FCA side of another master cord to the MS9710C input connector. Connect the connector on the other end (FAA) to the FAA connector connected to the power meter using an FC adapter (ordering number: J0057) of the application parts. (After that, do not disconnect the optical fiber cord connected to the MS9710C.)

Press the Auto Align function key (f6) in the Cal card of the MS9710C, and then press [Execute]. About one minute later, the optical axis is adjusted automatically. During calibration, the message [Execute Calibration ...] is displayed on the screen and any key other than [Cancel] is not accepted.

10.2.3 Level Offset Adjustment

Set Res to 0.2 nm. Set the sweep range to 5 nm. Press the Repeat key to measure the light in the standard level continuously and read the peak level with the peak search key. Press the Level Offset key of the Cal card and adjust the level by turning the rotary encoder so that the peak level value becomes the value measured in Section 10.2.1. The value adjusted here (offset value) is stored even after turning off the power. When the optical ATT is used in the ON state when measuring the NF, perform the level correction of the MS9710C with the optical ATT set to ON.

10.3 System Calibration

Next, calibrate the wavelength loss characteristics of the MF9619C optical modulator. The procedure is the same as that described in [Section 9.1 Calibration]. To improve the loss reproducibility at the time of connection/disconnection of the optical fiber cord, use a master cord (ordering number: J0846B). Connect the FCA side connectors of the master cords to the four optical connectors excluding the connector on the [Input Probe Signal] port of the MF9619C in advance. Do not disconnect the connectors on the FCA side during the period from the start of calibration to the completion of NF measurement. Connect the optical amplifier and the optical spectrum analyzer through an adapter and calibrate the system including the loss of the master cord.

The connection of optical fiber cords at the time of NF measurement is shown below.

Also use a master cord for the light source. To the I/O connectors of the optical amplifier, use the fused FAA side connector of the master cord. Though it is also possible to use other connectors, the NF measurement error caused by the loss reproducibility at the time of connection/disconnection must be taken account. Measure the loss reproducibility at the time of connection to, and disconnection from, the master cord in advance and use a connector with a loss reproducibility of 0.05 dB or less. If an optical fiber cord with a connector whose shape is other than the FC type connector is to be used, use a conversion adapter for the FC type connector. The relation between the connector shape of the optical fiber cord and the conversion adapter used is shown below.

Connector shape	Conversion adapter product name	Ordering number
FC connector	FC conversion adapter	J0057
ST connector	FC-ST conversion adapter	J0847A
DIN connector	FC-DIN conversion adapter	J0848A
SC connector	FC-SC conversion adapter	J0849B
HMS-10/A connector	FC-HMS-10A conversion adapter	J0850A

CAUTION

To connect an optical fiber cord, be sure to clean the cord end. Also check periodically to ensure that the receptacle of the system is cleaned. If the receptacle is used with dirt on it, not only the NF measurement accuracy is degraded but also the life of the connector is shortened. In the worst case, the parts may be burnt. For the cleaning method, see [12.1.4 Cleaning optical fiber cords] and [12.1.3 Cleaning optical connector].

 12.1.4 Cleaning optical fiber cords

 12.1.3 Cleaning optical connector

Section 11 Manipulating Graphs

This section describes the method of manipulating graphs including scaling up/down of a graph and change of colors. Note that some operations are not supported in some graphs.

11.1 Scaling Up and Down.....	11-2
11.2 Movement	11-3
11.3 Changing Axis Labels.....	11-4
11.4 Changing Background and Grid Colors.....	11-5
11.5 Cursor	11-6
11.6 Plot Style	11-8

11.1 Scaling Up and Down

This section describes the method of scaling up/down a graph.

- (1) Enter the numeric value of the axis label directly.

By clicking a label on either side of the graph and entering a numeric value from the keyboard directly, the graph can be scaled up or down.

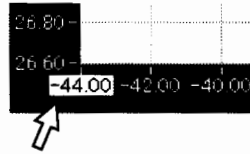

- (2) Scale up/down with a mouse.

Click the mark of a magnifying glass on the pallet at the lower right of the graph and select the range selecting method.

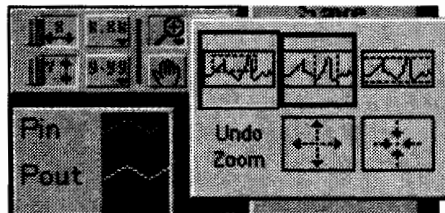

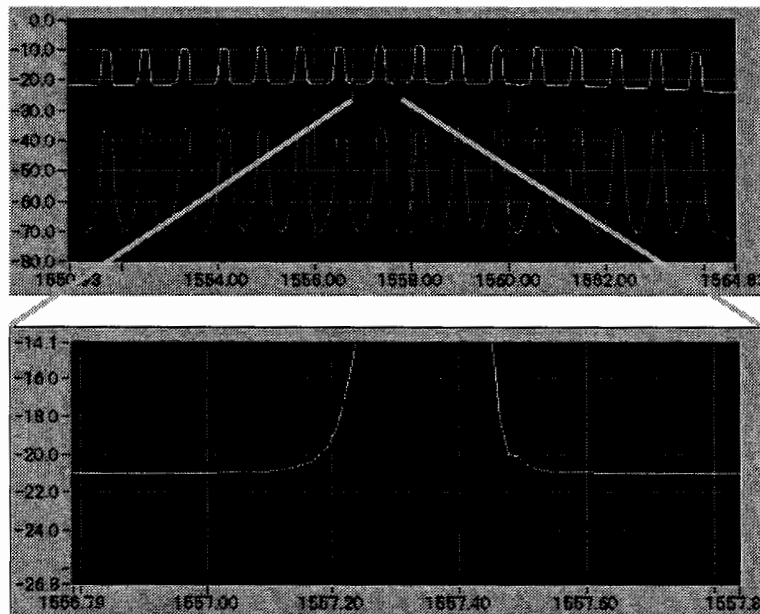

If the mouse is moved to the graph, the mouse shape is changed into the mark of a magnifying glass. By drawing the region to be scaled up in the shape of a rectangle, this region can be scaled up.



11.2 Movement

Click on the button of the mark of a palm  on the pallet at the lower right portion of the graph. If the mouse is moved to the graph, the mouse shape is changed into the mark of a palm. The graph can be moved by drawing the mouse.

If the  button on the pallet is clicked, the range of the horizontal axis is adjusted to the optimum value automatically. If the  button on the pallet is clicked, the range of the vertical axis is adjusted to the optimum value automatically.

11.3 Changing Axis Labels

A numeric value can be entered into the axis label from the keyboard directly after clicking the axis label. If a division on a scale beside (or above) the label is drawn with a mouse, the number corresponding the location is displayed automatically. To change the number of digits to be displayed, click the  button on the pallet and select [Precision], and then select the desired number of digits.

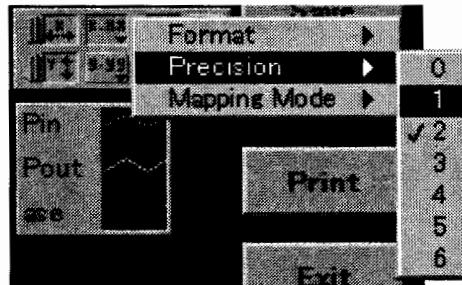

11.4 Changing Background and Grid Colors

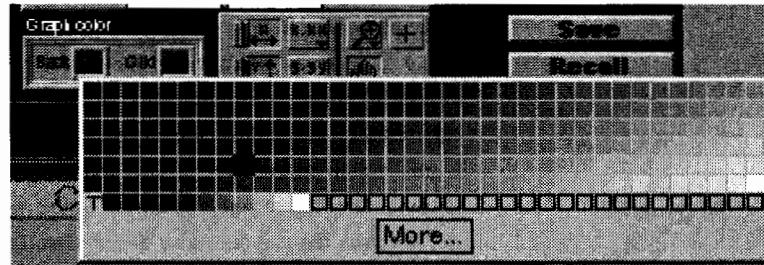

To change the background or grid color of the graph, use the [Graph color] box. To change the background color, click the [Back] box under [Graph color]. To change the grid color, click the [Grid] box under it. If the desired color is selected from the pallet, the color of the background or the grid is changed accordingly.



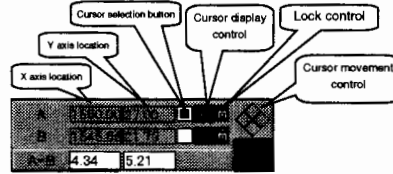

11.5 Cursor

To manipulate the cursor, use the cursor pallet under the graph.



If the  mark is displayed in the cursor selection button, this cursor is selected. If the  mark is displayed in the cursor selection button, this cursor is not selected. Each time the cursor selection button is clicked, the selected/non-selected state is changed alternately.

If the  mark on the right or left side in the cursor movement control pallet is clicked, the selected cursor is moved to the right or the left. If the both cursors are selected, the cursors move at the same time. If the  mark on the top or bottom in the cursor movement control pallet is clicked, the cursor moves upwards or downwards. If the cursor is in the locked state, the cursor can be moved to the previous or next plot by clicking the up/down button on the cursor movement control pallet. It is also possible to move the cursor by clicking the  button on the graph pallet and drawing the cursor with the mouse.

If the lock button is clicked, the pop-up menu for locking the cursor to the specific plot is displayed. If the cursor is locked to the plot, the button is changed to the shape of a locked key. The pop-up menu is shown in the following figure.

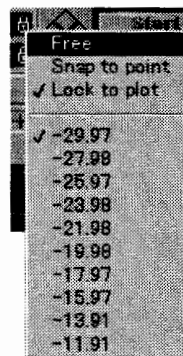

To place or move the cursor on/to be the desired location of the graph, select [Free]. To always make the cursor lock itself at the point nearest to a plot, select [Snap to point]. To lock the cursor to the specified plot, select [Lock to plot]. If [Lock to plot] is selected for the first time, the cursor locks itself at the initial point on the plot. If [Lock to plot] is selected after the locked cursor is released and moved to a new position, the cursor moves to the location at which the cursor is locked finally.

The numbers under [Lock to plot] are the names of the plots. In this example, there are ten types of plots. The plot with a check mark next to its number is the currently locked plot.

If the cursor display control button is clicked, the pop-up menu that can be used for controlling the appearance of the cursor on the plot is displayed.

To change the line type of the cursor, click [Cursor Style].

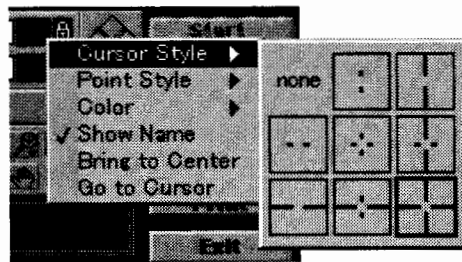

Select the line type from the pop-up menu.

To change the type of cursor point, click the [Point Style].

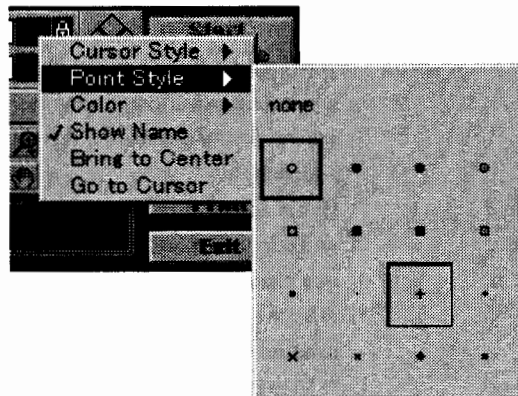

Select the point type from the pop-up menu.

To change the color of the cursor, click [Color].

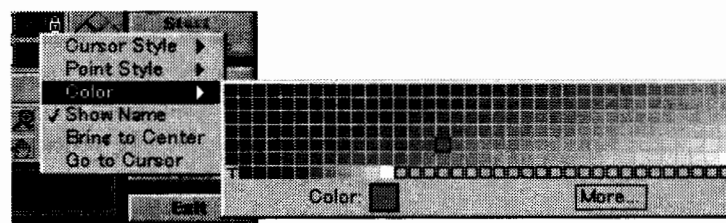

Select the color from the color pallet.

11.6 Plot Style

If the legend on the right side of the graph is clicked, the pop-up menu for changing the plot style is displayed. Click the mouse over the word in the legend corresponding to the plot to be changed.

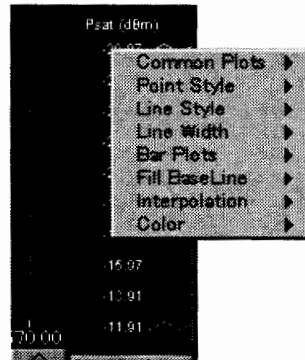

If [Common Plots] are specified, plots can be set to either of the six general plot styles (e.g., distributed plot, bar plot, fill plot up to zero) easily. With the options in this sub-pallet, the point, line, and file style can be set in advance in one step.

[Point Style], [Line Style], and [Line Width] display the styles that can be used to distinguish plots. The line width sub-pallet provides a wide line wider than one pixel of the default and a hair line option. Though the latter option is not effective on the screen display, a very narrow line is printed when hairline printing is supported by the printer and the print mode.

If [Bar Plots] is used, the vertical bar, horizontal bar, or no bar can be selected.

[Fill Base Line] is used to specify what the base line fills. “Zero” fills from the plot to the base line generated with zero. “Infinite” fills from the plot to the positive end of the graph. “-Infinite” fills from the plot to the negative end of the graph. Under this menu, select the specific plot to be filled in this graph.

[Interpolation] is used to select the method of drawing a line between the plotted points. The initial option is suited for distributed plots because it does not draw a line. The option at the lower left draws a straight line between the plotted points. The two stage option is suited for creating a plot like a histogram because it connects points in the shape of L. The option at the upper right plots the y axis first, while the option at the lower right plots the x axis first.

[Color] displays a pallet to select the plot color. If the coloring tool is used, it is also possible to color the plot of the legend.

Section 12 Maintenance and Re-transportation

This section describes cautions on daily maintenance and re-transportation.

12.1 Daily Maintenance.....	12-2
12.1.1 Dirty Appearance	12-2
12.1.2 Dirt on the Screen	12-2
12.1.3 Cleaning Optical Connectors	12-3
12.1.4 Cleaning Optical Fiber Cords.....	12-5
12.2 Cautions on Storage.....	12-6
12.3 Re-transportation	12-7
12.4 Before Calling Maintenance Persons	12-8

12.1 Daily Maintenance

12.1.1 Dirty Appearance

When the outside of the system is dirty, after the system is used in a dusty location, or before the system is stored for a long period, gently wipe off dirt on the system with cloth dipped in soapy water. The use of thinner or benzine may damage the coating on the system.

12.1.2 Dirt on the Screen

Wipe off dirt on the display screen of the MG9637A/MG9638A and the MS9710C with a dry and soft cloth. If dirt cannot be removed with a dry cloth, wipe off dirt with a cloth dipped in soapy water.

CAUTION

Before wiping off dirt with a cloth dipped in soapy water, remove the power cord from the power outlet. If cleaning is made without disconnecting the power cord from the power outlet, there is a danger of electric shock.

Never disassemble or lubricate the system. Each measuring instrument in the system contains several micron order precision mechanical parts. Therefore, disassembling or lubricating the system may prevent the system from operating normally.

12.1.3 Cleaning Optical Connectors

Clean the ferrules in the optical connectors in the MG9637A/MG9638A, MN9610B/MN9611B, MF9619C, and MS9710C using the following method. It is recommended that ferrules be cleaned periodically.

- (1) Open the cap of the protection cap.
- (2) Raise the lever of the replaceable optical connector to release the lock.

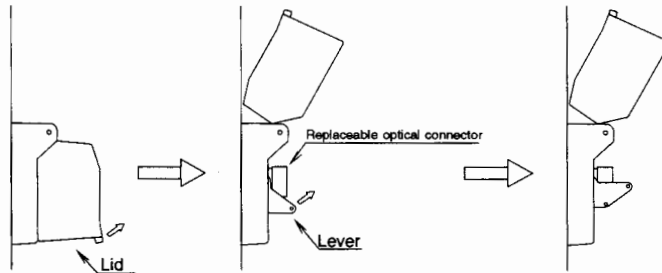

- (3) Pull the lever in direction A to remove the front shell of the replaceable optical connector.
- (4) The ferrule end of the built-in optical fiber can be seen. Clean the ferrule. For cleaning, use of the adapter cleaner Z0284 of the application parts is recommended.

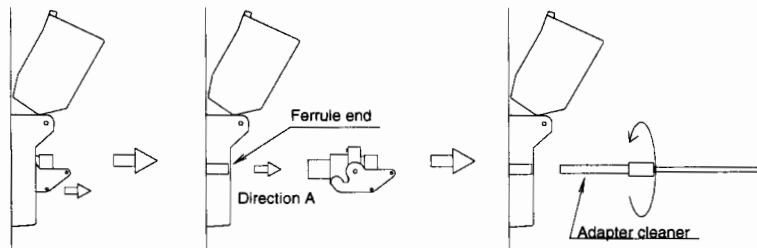

- (5) While lifting the lever, insert the replaceable optical connector into the ferrule of the built-in optical fiber as far as it will go in direction B. At this time, insert the guide pin on the front shell side and the hole on the rear shell side so that they fit into each other. Take care not to cause scratches and dirt on the ferrule end.

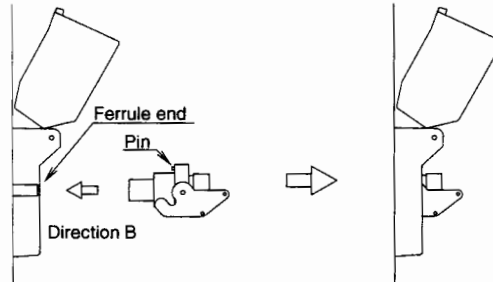

- (6) If the lever is lowered until a click is heard, the lever is locked and fixed.

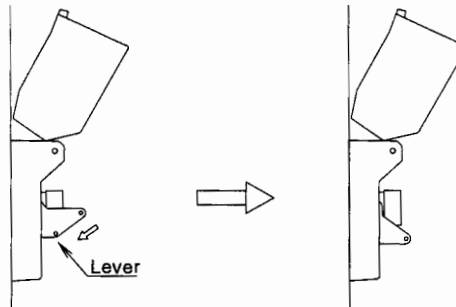

CAUTION

When cleaning the end of the optical fiber cord, never use cotton swabs dipped in alcohol because dirt may remain at the center of the ferrule when alcohol evaporates. To clean the optical fiber cord built in the measuring instrument, use adapter cleaner (Z0284) that need not be dipped in alcohol.

If the system is used with dirt on the end of the ferrule, not only the NF measurement accuracy is degraded but also the life of the connector is shortened. If high output light is used in this state, the connected fiber or the fiber end built in the measuring instrument may be burnt.

12.1.4 Cleaning Optical Fiber Cords

To clean the ferrule on the connected optical fiber cord end, use the ferrule cleaner (ordering number: Z0283) of the application parts.

CAUTION

When cleaning the end of the optical fiber cord, never use cotton swabs dipped in alcohol because dirt may remain at the center of the ferrule when alcohol evaporates. To clean an optical fiber cord, use ferrule cleaner (Z0283) that need not be dipped in alcohol.

Optical fiber cords are consumables. By connecting and disconnecting the connector, the ferrule wears out and the ferrule end is damaged. Replace the optical fiber cord with a new one periodically.

12.2 Cautions on Storage

When storing the system, avoid the following locations.

- A location over 60 °C or more or -20 °C or less in temperature.
- A location exposed to direct sunlight
- A dusty location
- A location that is so moist that water droplets attach on the system
- A location that may be exposed to active gas

12.3 Re-transportation

To transport the system again, observe the following.

- Use the packing material that is used for packing at the time of purchase.
- Instruct the carrier to keep the system level when transporting it.
- The eyebolts on the upper surface are for fastening the system to the ceiling. If these eyebolts are used to lift and move the system rack, the system may fall because too large power is applied to the eyebolts. Therefore, never move the system with a crane using these eyebolts.



If the packing material is lost, pack the device in the following method.

1. Pack the device with vinyl.
2. Use a corrugated, wooden, or aluminum box that is larger than the device by 10 to 15 cm from each direction, and lay cushioning material of 10 to 15 cm at the bottom of the box.
3. Put the device packed with vinyl into the box and put cushioning material around the device.
4. Fasten the box with a rope, tape, or band firmly.

12.4 Before Calling Maintenance Persons

Problem	Possible Cause	Solutions
The power is not turned on.	The breaker of the entire system is not turned on (when a system rack is used).	Turn on the breaker.
	The power switch of each measuring instrument is not pushed firmly.	Push the power switch of each measuring instrument firmly.
	The AC power input connector in the system rack and the power cord is not connected firmly or the power cord and the power supply is not connected firmly (when a system rack is used).	Connect the AC power input connector in the system rack, the power cord, and the power supply firmly.
	The AC power input connector in each measuring instrument and the power cord are not connected firmly or the power cord and the power supply (a table tap in the system rack: when a system rack is used) is not connected firmly.	Connect the AC power input connector in each measuring instrument and the power cord or the power cord and the power supply (a table tap in the system rack: when a system rack is used) correctly.
	The fuse is burnt.	Replace the fuse. ☞ Paragraph 3.7
Though two hours or more have elapsed since the MG9637A / MG9638A was turned on, the heat-up percentage does not reach 100 %.	The ambient temperature is too low.	Use in an ambient temperature between 10 to 35 °C.
	The heater is at fault.	Turn off the power supply immediately and contact the service center.
Though two minutes or more have elapsed since the MS9710C was turned on, the initializing screen does not come to an end.	The program is started during the initialization of the MS9710C.	Turn off the MS9710C to stop the program and turn on the MS9710C again. ☞ Paragraph 4.4
		Turn off the MS9710B once and turn on it again. If the state does not change after this operation, turn off the power supply immediately and contact the service center.

Problem	Possible Cause	Solutions
The optical fiber cord cannot be connected.	The shape of the optical fiber cord is different from that of the connector.	Use a connector of the correct shape. ☞ Paragraph 3.6
	The location of the claw of the connector does not fit.	Check the location and orientation of the claw and connect again.
The program does not start.	The installation is not completed correctly.	Install the software in the personal computer correctly. ☞ Paragraph 4.2
	A file is moved or deleted.	If the program file is moved or deleted, install the software again. ☞ Paragraph 4.2
Each measuring instrument does not enter the remote state.	The GPIB cable is not connected.	Connect each measuring instrument to the personal computer using a GPIB cable. ☞ Paragraph 4.3
	The GPIB address setting is not correct.	Set the GPIB address set in each measuring instrument and the GPIB address set on the setup panel to the same value. ☞ Paragraphs 6.1,7.1, and 8.1
	Another device is connected. The GPIB address is conflicting.	If a device other than the system is connected to GPIB, check that the GPIB address is not conflicting and that a controller other than the personal computer for control is not connected. ☞ Paragraphs 6.1,7.1, and 8.1
	The GPIB interface card is not installed in the personal computer.	Install the GPIB interface card and the interface software in the personal computer. ☞ Paragraph 4.1
	A file is moved or deleted.	If the program file is moved or deleted, install the software again. ☞ Paragraph 4.2

Problem	Possible Cause	Solutions
<p>The message [GPIB Board Error!!] is displayed.</p> 	<p>The port number into which the GPIB interface card is inserted is different from the setting.</p>	<p>Enter the port number into which the GPIB interface card is inserted into the [GPIB Board] input box and click the [Retry] button.</p> <p>If only one GPIB interface card is used, the port number is normally zero.</p>
	<p>The GPIB interface card is not installed in the personal computer.</p>	<p>Install the GPIB interface card and the interface software in the personal computer.</p> <p>☞ Paragraph 4.1</p>
<p>The message [GPIB ERROR!!!] is displayed.</p> 	<p>The GPIB cable is not connected.</p>	<p>Connect the personal computer and each measuring instrument using a GPIB cable and click the [Retry] button.</p> <p>☞ Paragraph 4.3</p>
	<p>The GPIB address setting is not correct.</p>	<p>Click the [Retry] button and set the GPIB address set in each measuring instrument and the GPIB address set on the setup panel to the same value.</p> <p>☞ Paragraphs 6.1,7.1, and 8.1</p>
	<p>Another device is connected. The GPIB address is conflicting.</p>	<p>If a device other than the system is connected to GPIB, check that the GPIB address is not conflicting and that a controller other than the personal computer for control is not connected.</p> <p>☞ Paragraphs 6.1,7.1, and 8.1</p>
<p>The RS232C error is displayed.</p> 	<p>The RS232C cable is not connected.</p>	<p>Connect the personal computer and the MS9710C with an RS232C cable and click the [Retry] button.</p> <p>☞ Paragraph 8.1</p>

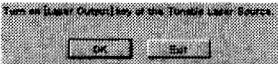
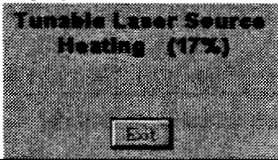
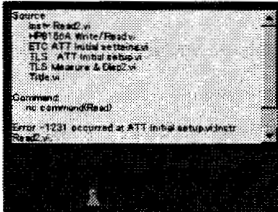
Problem	Possible Cause	Solutions
	The serial port number is not correct.	Click the [Retry] button and enter the serial port number to which an RS232C cable is connected into the [Serial Port] box. ☞ Paragraph 8.1
<p>The message [Short Remote Interlock Connector of Tunable Laser Source.] is displayed.</p> 	The [remoter interlock] on the rear side of the MG9637A/38A tunable laser source is open.	Set the remoter interlock to the short state and click the [OK] button. ☞ MG9637A/38A Operation Manual
<p>The message [Turn on Laser Output key of the Tunable Laser Source.] is displayed.</p> 	The [Laser Output] key on the front side of the MG9637A/38A tunable laser source is turned off.	Set the key to ON and click the [OK] button. ☞ MG9637A/38A Operation Manual
<p>The message [Tunable Laser Source Heating] is displayed.</p> 	The tunable laser source is being heated.	Wait until the heating is completed. Measurement will start automatically. (If the [Exit] button is clicked, measurement is suspended.)
<p>The GPIB error dialog box is displayed.</p> 	The type of the connected device is different from the setting.	Click the [Abort] button and stop the program once. (After the program is stopped, close all panels other than the start panel.) Start the program again and set the [Setup] panel correctly. ☞ Paragraphs 7.1, and 8.1
	Though the MS9710B without SLD option is used, [SLD] is selected as the type of probe light.	Click the [Abort] button and stop the program once. (After the program is stopped, close all panels other than the start panel.) Start the program again and set the type of the probe light correctly on the [Setup] panel. ☞ Paragraph 8.1

Section 12 Maintenance and Re-transportation

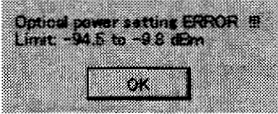
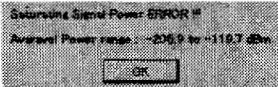
Problem	Possible Cause	Solutions
<p>The following level error is displayed.</p>  	<p>The power that is out of the tunable laser source output range is set on the [Setup] panel.</p>	<p>Set the power within the range of power displayed in the dialog box on the [Setup] panel again.</p> <p>☞ Paragraphs 7.1, and 8.1</p>
<p>The measured results are not normal.</p> <p>Characters other than numeric values are displayed.</p>	<p>Calibration is not performed correctly.</p>	<p>Perform calibration correctly.</p> <p>☞ Paragraph 9.1</p>
	<p>Calibration for using the probe method is not performed correctly.</p>	<p>Perform calibration correctly.</p> <p>☞ Paragraph 9.1</p>
	<p>A signal is entered into the optical amplifier when performing calibration.</p>	<p>When performing calibration, the output light of the optical amplifier without signal light input is used. Perform calibration again.</p> <p>☞ Paragraph 9.1</p>
	<p>The connector is dirty.</p>	<p>Clean the connector and optical fiber cord.</p> <p>☞ Paragraphs 12.1.3 and 12.1.4</p>
	<p>The level calibration of the MS9710C is not performed correctly.</p>	<p>Perform the level calibration of the MS9710C correctly.</p> <p>☞ Paragraph 10.2</p>
	<p>The delay time setting is not appropriate.</p>	<p>Set the delay time on the Setup screen to [Adjust only at first measurement] and measure again.</p> <p>☞ Paragraphs 6.2, 7.1 and 8.1</p>
	<p>Connection failure of the optical fiber cord.</p>	<p>Connect the optical fiber cord correctly.</p> <p>☞ Paragraphs 3.5 and 3.6</p>

Problem	Possible Cause	Solutions
Signal light is not detected.	The connector is dirty.	Clean the connector and optical fiber cord. ☛ Paragraphs 12.1.3 and 12.1.4
	Connection failure of the optical fiber cord.	Connect the optical fiber cord correctly. ☛ Paragraphs 12.1.3 and 12.1.4
The measured results cannot be printed.	The printer is not installed.	Install the printer and set the environment in which the printer can be used with Windows applications.

12-14.

Section 13 Performance Check and Calibration

This section describes the method of checking the performance of the system. To maintain the performance of the system and make an accurate measurement, it is recommended that performance check be made at least once every six months.

If the performance check revealed that the standard was not satisfied, repair or calibration is required. Contact your nearest local office, branch office, sales office, or distributor described in this manual immediately.

When requesting us to repair or calibrate a device, the following information needs to be provided together with the device.

- [1] Device name and machine number on the rear panel
- [2] The version number described on the floppy disk containing the program
- [3] Description of trouble
- [4] The name and the telephone number of the person in charge to whom we can ask questions about the nature of the problem or to whom we can report the completion of repair.

13.1 Performance Check	13-2
13.1.1 NF Measurement reproducibility	13-2
13.1.2 Insertion Loss.....	13-2
13.2 Calibration	13-2

13.1 Performance Check

To check the performance of the system, test the following two items.

- NF measurement reproducibility
- Insertion loss

Since there is no method of measuring the NF value accurately, NF measurement accuracy is not tested.

 10.1 Error Factors

Before conducting test, clean the optical connector and optical fiber cord end.

 12.1.3 Cleaning optical connectors

 12.1.4 Cleaning optical fiber cords

After turning on the power, heat up the system for two hours or more, and then perform calibration before starting test.

13.1.1 NF Measurement Reproducibility

Using an optical amplifier with stable NF values, measure the NF for five minutes continuously in the normal mode (optical pulse measurement mode), and calculate the reproducibility of the measured results.

Check that the reproducibility measurement result is equal to or less than the standard value 0.2 dB.

13.1.2 Insertion Loss

By reading the insertion loss of the MF9619C optical modulator from the calibration panel and check that the insertion loss is equal to or less than the standard value. The standard value of the insertion loss is different between the standard type and option 01 (SLD supporting type).

Check the type of device used.

 9.2 Checking Calibration Data

13.2 Calibration

Except [Section 9 CALIBRATION] and [Section 10 To Make Highly Accurate Measurement], there is no item to be calibrated by the user. If the performance check in Section 13.1 revealed that the standard was not satisfied, repair or calibration is required. Contact your nearest local office, branch office, sales office or distributor listed in this manual immediately. For devices other than the MF9619C optical modulator, see individual manuals.

Section 14 Appendix

This section describes supplementary remarks concerning the principle of operation and the system.

14.1	Principle of Operation.....	14-2
14.1.1	Normal Mode and Tunable Laser Source Interlock Measurement Mode.....	14-3
14.1.2	Probe Method Measurement Mode.....	14-4
14.2	Measurement Power.....	14-5
14.3	Delay Time.....	14-6
14.4	Modulation Frequency.....	14-7
14.5	Measurement Time.....	14-8
14.5.1	Normal Mode.....	14-8
14.5.2	Tunable Laser Source Interlock Measurement Mode.....	14-8
14.5.3	Probe Method Measurement Mode.....	14-8
14.6	Optical Surge.....	14-9
14.7	Data Saving Format.....	14-10
14.7.1	Normal Measurement Mode.....	14-10
14.7.2	Tunable Laser Source Interlock Measurement Mode.....	14-11
14.7.3	Probe method Measurement Mode.....	14-12
14.8	Changing Wavelength Range.....	14-13
14.9	Reading Data without Measuring Instruments.....	14-14
14.10	Performance Test Result List.....	14-15

14.1 Principle of Operation

The optical method of the NF measurement using an optical spectrum analyzer calculates the NF value from the measured results of the gain and the amplified spontaneous emission light (ASE) power (PASE). In the system, the NF is calculated using the following equation.

$$NF = PASE \cdot \lambda^3 / (h \cdot c^2 \cdot Res \cdot Gain) + 1 / Gain$$

$$Gain = (P_{out} - P_{ASE}) / P_{in}$$

λ : Signal light wavelength

h: Planck's constant

c: Velocity of light in vacuum

P_{out}: Output light power

P_{in}: Input light power

Res: Resolution of optical spectrum analyzer

The gain can easily be accurately measured from the ratio of the input light power (P_{in}) to the output light power (P_{out}). Since the ASE is hidden in the amplified signal light, it is necessary to separate it from the amplified signal light.

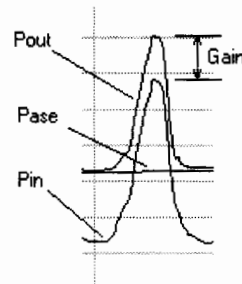

As methods of separating the ASE from the amplified signal light, the fitting method and the polarization nulling method have been used. The former is the method of estimating the ASE level in the signal light wavelength from the noise level on either side of the amplified signal light wavelength. The latter is the method of removing amplified light components using the polarization controller and the analyzer. In the fitting method, however, the ASE level cannot be estimated correctly if the wavelength characteristics of the ASE component are significantly inclined or if the wavelength intervals of the wavelength division multiplex signals are narrow. With the polarization nulling method, measurements cannot be made correctly because of the leaked components of the amplified light.

In the system, the ASE is measured directly by separating the amplified signal light and the ASE component with the pulse method using the external modulator. Therefore, the NF can be measured accurately.

The internal block diagram of the MF9619C optical modulator is shown below.

14.1.1 Normal Mode and Tunable Laser Source Interlock Measurement Mode

The signal light source is input from the [Input Saturating Signal] port and turned on and off at a modulation frequency of 125 kHz (default) and at a duty of 50 % using Optical Modulator 1 (AOM1). The modulated rectangle signal is input to the optical amplifier. The amplified signal light is turned on and off at a modulation frequency of 125 kHz (default) and at a duty of 25 % using Optical Modulator 2 (AOM2). By adjusting the phase of AOM2 so that AOM2 is turned on only in a timing in which no amplified light exists, only the ASE component is passed.

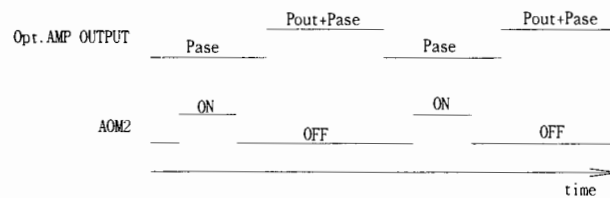

The responding speed of the ASE such as an erbium doped optical fiber amplifier is normally 10 kHz or less. Since the optical modulator is modulated at 125 kHz that is much higher than the responding speed of the ASE, the ASE component maintains the same power as in the amplified state even in a timing without amplified signals.

The optical spectrum analyzer measures this isolated ASE component through a low pass filter that is much lower than the modulation frequency. This method improves the minimum light acceptance sensitivity significantly compared with the synchronized measurement.

The on/off extinction ratio of the MF9619C internal optical modulator is 65 dB or more. Therefore, it is possible to turn off the input light completely in the ASE measurement timing. The amplified light never leaks into the ASE component.

To measure the input light power, lead the input light to the optical spectrum analyzer directly by switching the MF9619C internal optical switch, measure the power, subtract the loss of the optical path measured at the time of calibration, and calculate the power input to the optical amplifier.

To measure the amplified light power, lead the amplified light to the optical spectrum analyzer directly by switching the MF9619C internal optical switch, measure the power, subtract the loss of the optical path measured at the time of calibration, and calculate the power output from the optical amplifier.

14.1.2 Probe Method Measurement Mode

To measure the ASE level of the optical amplifier, set the saturating signal light to on and the probe light to off, and measure the ASE level in the same manner as the ASE measurement in the previous section. (A probe method measurement is made based on the premise that the probe light power is small enough not to affect the locked inversion state of the optical amplifier.)

Next, turn the probe light to on and make a measurement in the same timing as the ASE measurement. Since the probe light is not modulated with AOM1, the amplified probe light component is added to the ASE and output. By subtracting the previously measured ASE level from the measured results, the amplified probe light component is calculated.

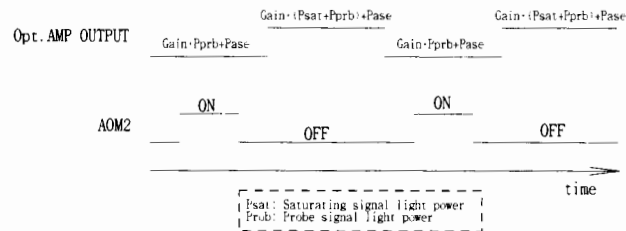

To measure the probe light power input to the optical amplifier, switch the internal optical switch so that the probe light is input into the optical spectrum analyzer directly. At this time, set the saturating signal light to off. Calculate the gain from the ratio of the measured results to the previously measured [amplified probe light component].

14.2 Measurement Power

As described in Section 14.1, the input light and amplified light of the optical amplifier is modulated at a frequency of 125 kHz (default) and at a duty of 50 %. The power of the input light and the amplified light measured in the system is an average value. Since the optical amplifier is influenced by the average power rather than the peak power, the average power is displayed in the system.

14.3 Delay Time

The delay time is the value of the phase of Optical Modulator 2 described in Section 14.1.

The signal modulated in Optical Modulator 1 is delayed by the optical amplifier. This delay time differs depending on the fiber length of the optical amplifier under measurement.

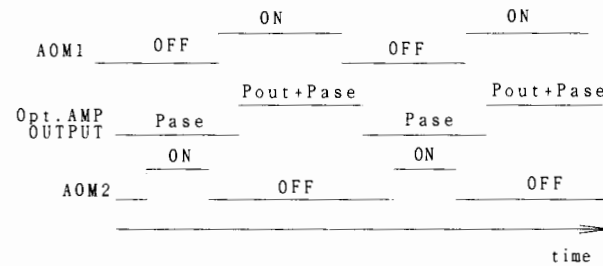

In the system, the phase of AOM2 is adjusted in steps of 1/16 the modulation cycle. Since the duty of AOM2 is 25 % while the duty of AOM1 is 50 %, there is a margin of (1 step in the delay time).

When the delay time is to be set can be set on the Setup panel (in the normal measurement mode, [Auto Measure] measurement only.)

 6.2 Measurement

14.4 Modulation Frequency

The modulation frequency of the optical modulator inside the MF9619C can be changed on the Setup panel. The default value is 125 kHz. When the modulation frequency is changed, the insertion loss is also changed. Be sure to perform calibration after change.

 Section 9 Calibration

The delay time is also changed. Before starting measurement, adjust the delay time too.

CAUTION

If a frequency higher than 250 kHz is set, some measuring instruments do not operate normally because the insertion loss increases too much. This is because of the response characteristics of the optical modulator inside the measuring instrument.

If a measuring instrument is used at a frequency lower than the ASE responding speed, the reading of the NF becomes high because of high ASE measured value.

Anritsu Corp. does not guarantee the use of a measuring instrument at a modulation frequency other than 125 kHz and 250 kHz.

14.5 Measurement Time

14.5.1 Normal Mode

If only one signal light is used, the measurement time is about one minute. When the delay time is set, an additional 20 seconds are required.

If multiple signal lights are used, the following measurement time is required. The time differs depending on the wavelength width (maximum wavelength (minimum wavelength + 1.6 nm) of the signal light.

Wavelength (nm)	Measurement time	Number of sampling points
2.5 nm or less	About 1 minute	101
5 nm or less	About 1 minute and half	251
10 nm or less	About 2 minutes and half	501
20 nm or less	About 3 minutes and half	1001
40 nm or less	About 5 minutes and half	2001
Over 40 nm	About 12 minutes	5001

For the WDM using 16 mixed waves spaced 0.8 nm, for example, the wavelength width is 12.8 nm. Therefore, the measurement time is about 3 minutes and half. If there are only two signal light wavelengths and the wavelength interval is about 20 nm, two measurements are made as the wavelength as 2.5 nm. In this case, it takes about two minutes to make measurements.

14.5.2 Tunable Laser Source Interlock Measurement Mode

If the wavelength is changed ten times, the measurement time is about four minutes and half (when [Spectrum Measurement] is set to OFF).

If a matrix measurement in which the wavelength and power are changed ten times each is made, the measurement time is about 26 minutes (when [Spectrum Measurement] is set to OFF).

14.5.3 Probe Method Measurement Mode

- When the tunable laser source is used as a probe light

If measurements are made at 51 sampling points with the parameters such as the saturating signal light wavelength fixed, the measurement time is about three minutes.

If a measurement is made while changing the parameter ten times, the measurement time is about 20 minutes.

- When the SLD (MS9710c option) is used as a probe light

If measurements are made at 51 sampling points with the parameters such as the saturating signal light wavelength fixed, the measurement time is about two minutes.

If a measurement is made while changing the parameter ten times, the measurement time is about 13 minutes.

14.6 Optical Surge

If a stepped signal light is input to an optical amplifier with no input, high level light is output instantaneously due to the optical surge. This phenomenon occurs because the energy stored at no input time is discharged the moment a stepped signal light is applied. Normally, as the input signal increases, the gain decreases. However, if a stepped input is applied, the input signal light is multiplied by the gain at the time of small signal input. That is, if a stepped light of 0 dBm is input to an optical amplifier with a small signal gain of 30 dBm, a light of +30 dBm is output instantaneously.

In the system, no light is input to the optical amplifier when measuring P_{in} and the optical switch is switched to the optical amplifier side when P_{out} is measured. At this time, a stepped light is input to the optical amplifier. Though the gain at the small signal input time is not amplified because the switching time of the optical switch is as slow as about 0.2 msec, power higher than that in the steady state is output from the optical amplifier instantaneously. Anritsu Corp. validated that power of +17 dBm was output the moment the P_{out} measurement was started when the output light of an optical fiber amplifier (auto power control) whose output light is +14 dBm in the steady state operated the system using and a light source of -4 dBm (since the loss of the MF9619C is 8 dBm, the input light power to the optical amplifier is -12 dBm).

Since the insertion loss of the MF9619C is around 8 dB (in the standard type) in 1580 nm, there is no problem in most amplifiers if the signal light power is 10 dB or less. However, if an optical amplifier with a small signal gain of 40 dB or more is measured or if a signal light of 0 dBm or more is used, the high output light that is output instantaneously may burn the measuring instrument.

When such a measurement must be made, check the power of the light output from the optical amplifier when starting the measurement of P_{out} using an O/E converter (+ optical attenuator) and oscilloscope before connecting the output of the optical amplifier to Port B of the MF9619C. If the measured result exceeds the maximum input permissible range of Port B, insert an optical attenuator before Port B to protect the measuring instrument. If the inserted optical amplifier is included in calibration, it does not affect the NF measured results.

14.7 Data Saving Format

14.7.1 Normal Measurement Mode

In the normal measurement mode, data is saved in text format. As shown below, data consists of table data in the first half and waveform data in the latter half.

Result of NF measurement					
Number of table data>8					
Wavelength(nm)	>NF(dB)	>Gain(dB)	>Pin(dBm)	>Pout(dBm)	>ASE(dBm/nm)
1549.86	>8.52	>10.08	>-12.29	>-2.21	>-29.33
1550.69	>8.40	>10.86	>-12.37	>-1.51	>-28.65
1551.57	>8.44	>11.61	>-12.43	>-0.82	>-27.95
1552.47	>8.50	>12.16	>-11.88	>0.28	>-27.36
1547.86	>8.52	>10.08	>-12.29	>-2.21	>-29.33
1548.69	>8.40	>10.86	>-12.37	>-1.51	>-28.65
1565.57	>8.44	>11.61	>-12.43	>-0.82	>-27.95
1567.47	>8.50	>12.16	>-11.88	>0.28	>-27.36
Spectrum data					
Number of sampling points >501					
Wavelength(nm)	>Pin(dBm)	>Pout(dBm)	>ASE(dBm)		
1548.000	>-56.200	>-39.940	>-40.710		
1548.012	>-55.580	>-39.850	>-40.650		
1548.024	>-54.820	>-39.690	>-40.610		
1548.036	>-54.350	>-39.580	>-40.590		
1548.048	>-53.740	>-39.430	>-40.580		
↓	> ↓	> ↓	> ↓		

Data is delimited by a tab. (It is indicated with ">".)

In Line 1, the title of the table data is described.

In Line 2, the number of table data items is saved. (The number next to [Number of table data>] is the number of data items.)

In Line 3, the items of the table data are described.

In Line 4 and later, table data is described.

For the waveform data, the number of points of the waveform data is saved in Line 2 of the waveform data and the waveform data is saved in Line 4 and later.

14.7.2 Tunable Laser Source Interlock Measurement Mode

After clicking the Save button and specifying the file name, a dialog box asking whether to create a text file is displayed. If [Yes] is specified there, a text file is created.

ME7890B Optical Amplifier Test System (TLS tracking)					
Result of NF measurement					
Number of table data>100					
Wavelength(nm)	>NF(dB)	>Gain(dB)	>Pin(dBm)	>Pout(dBm)	>ASE(dBm/nm)
1529.94	>34.89	>11.11	>-50.00	>-7.87	>-8.77
1529.94	>35.16	>10.84	>-45.53	>-6.50	>-8.78
1529.94	>35.23	>10.71	>-41.12	>-4.12	>-8.84
1529.94	>35.14	>10.64	>-36.66	>-0.81	>-8.99
1529.94	>34.77	>10.62	>-32.21	>2.82	>-9.39
1529.94	>33.86	>10.63	>-27.77	>6.18	>-10.29
1529.94	>32.21	>10.60	>-23.32	>8.92	>-11.96
1529.94	>29.57	>10.60	>-18.88	>10.69	>-14.61
1529.94	>26.17	>10.58	>-14.45	>11.72	>-18.02
1529.94	>22.31	>10.67	>-10.01	>12.29	>-21.80
1534.38	>34.54	>10.22	>-49.78	>-8.91	>-10.06
↓	> ↓	> ↓	> ↓	> ↓	> ↓

Data is delimited by a tab. (It is indicated with ">".)

The number next to [Number of table data>] in Line 5 is the number of data items.

In Line 7 and later, table data is described.

CAUTION

The spectrum data measured when the [Spectrum measurement] switch on the Setup screen is turned on is not saved in a text file.

14.7.3 Probe Method Measurement Mode

After clicking the Save button and specifying the file name, a dialog box asking whether to create a text file is displayed. If [Yes] is specified there, a text file is created. Data measured by changing the probe light power at intervals of 3.3 dB from -50 dBm to -20 dBm with a tunable laser source used as a probe signal is shown in the following.

```

ME7890B ...Omitted... (Probe method with Tunable LASER Source for probe
signal)

Result of measurement
Number of data>10

No.>1
Wsat(nm)>1530.15
Psat(dBm)>-11.92
Sampling points>51
Wavelength(nm) >NF(dB)>Gain(dB) >Pin(dBm) >Pout(dBm)>PASE(dBm)
1530.00 >10.08 >22.09 >-50.19 >-28.10 >-22.65
1530.80 >9.98 >22.98 >-50.18 >-27.20 >-21.89
↓ > ↓ > ↓ > ↓ > ↓ > ↓
1569.20 >5.72 >21.48 >-50.00 >-28.52 >-28.11
1570.00 >5.67 >20.59 >-50.02 >-29.43 >-29.06

No.>2
Wsat(nm)>1530.15
Psat(dBm)>-11.92
Sampling points>51
Wavelength(nm) >NF(dB)>Gain(dB) >Pin(dBm) >Pout(dBm)>PASE(dBm)
1530.00 >10.14 >22.05 >-46.83 >-24.78 >-22.64
1530.80 >10.06 >22.91 >-46.82 >-23.91 >-21.87
↓ > ↓ > ↓ > ↓ > ↓ > ↓
1569.20 >5.75 >21.45 >-46.66 >-25.21 >-28.11
1570.00 >5.68 >20.58 >-46.69 >-26.11 >-29.06
↓

```

Data is delimited by a tab. (It is indicated with ">".)

In Line 1, the title, the measurement mode, and the type of probe light source are described. (They are omitted in the above figure.)

The number next to [Number of table data>] in Line 5 is the number of data items. In Line 8 and later, table data is described from No.1, No.2, ... to No. n. The number following [Wsat (nm)>] in Line 2 in each measurement data is the wavelength of the saturating signal light. If WDM signals are used, it is the average value of the wavelength. The number following [Psat (dBm)>] in Line 3 in each measurement data is the power of saturating signal light. If WDM signals are used, it is the total value of power. The number following [Sampling points>] in Line 4 in each measurement data is the number of sampling points. In Line 6 and later, the data of each sampling point is described.

14.8 Changing Wavelength Range

The range of measurable wavelength (the default: 1525 to 1635 nm) in the system can be changed.

Open the [Wrange.dat] file in the [cond] folder in the folder in which the program is installed with a text editor (e.g., Word pad). [Wavelength Range : 1525 to 1635 nm] is described as a default value. To change the value, overwrite the desired wavelength range and save the specified value. The wavelength range will be changed.

On the Setup panel, check that the previously set wavelength is within the new wavelength range. If the entered value is out of the wavelength range, re-enter a value within the wavelength range. (Even if a value out of the wavelength range is entered, it is changed to a value within the range automatically.)

Perform calibration again. Calibration data within a new wavelength range is created.

 9.1 Calibration

CAUTION

If the power is too small, the measurement error may be increased due to the influence of noises.

If a value out of the wavelength range is specified in a measuring instrument such as a tunable laser source, a GPIB error occurs. If a GPIB error occurs, click the [abort] button to suspend the program once, and then correct the wavelength range.

14.9 Reading Data without Measuring Instruments

When exiting the Setup panel (or when moving to the measurement panel in the normal measurement mode), the type and the GPIB address of the connected measuring instrument are checked. If no measuring instrument is connected, an error dialog box is displayed.

To read the saved measured results without connecting measuring instruments, click the [Data recall] button. Data can be recalled, re-saved, and printed. The measurement button and Calibrate card are dimmed so that they cannot be clicked. To make a measurement, click the setup card and set the system again.

14.10 Performance Test Result List

Place of Test: _____ Report No. _____
 _____ Data _____
 _____ Tested by _____

Model name ME7890B Optical Amplifier Test System
 Serial No. _____ Temperature _____ °C
 Power source frequency _____ Hz Humidity _____ %

Special mention

Test Items	Minimum specification value	Results	Maximum specification Value	Remarks
<ul style="list-style-type: none"> • NF measurement reproducibility • Insertion loss 				

14-16.

Anritsu Service and Sales offices

America

Anritsu Company (ACUS)

685-A Jarvis Drive Morgan Hill, CA
95037-2809, U.S.A.
Phone: +1-408-776-8300
Fax: +1-408-776-1738

Anritsu Company (ACUS-NJ) Dist.5

10 New Maple Avenue, P.O. Box 836
Pine Brook, NJ 07058-0836, U.S.A.
Phone: +1-973-227-8999
Fax: +1-973-575-0092

Anritsu Company (ACUS-Maryland) Dist.6

19630 Club House Road, #710
Gaithersburg, MD 20879, U.S.A.
Phone: +1-301-590-0300
Fax: +1-301-216-2893

Anritsu Company (ACUS-Tx) NARO

1155 East Collins Blvd
Richardson, TX 75081, U.S.A.
Phone: +1-972-644-1777
Fax: +1-972-644-3416

Anritsu Electronics Ltd (ACCA)

5A-245 Matheson Blvd. East, Mississauga,
Ontario, L4Z 3C9, Canada
Phone: +1-905-890-7799
Fax: +1-905-890-2290

Anritsu Electronics Ltd (ACCA)

102-215 Stafford Road West Nepean,
Ontario, K2H 9C1, Canada
Phone: +1-613-828-4090
Fax: +1-613-828-5400

Anritsu Electronics Ltd (ACCA)

200-1405 Trans Canada Highway
Dorval, Quebec H9P 2V9, Canada
Phone: +1-514-421-3737
Fax: +1-514-685-9839

Anritsu Electronics Ltd (ACCA-Calgary)

Deerfoot Atrium, Suite 129, 6715-8th Street
N.E., Calgary, AB, T2E 7H7, Canada
Phone: +1-403-275-9855
Fax: +1-403-275-3609

Anritsu Eletrônica Ltd (ACBR)

Praia de Botafogo, 440-Sala 2401
CEP 22250-040, Rio de Janeiro, RJ, Brasil
Phone: +55-21-5276922
Fax: +55-21-537-1456

Anritsu Eletrônica Ltd (ACBR) Sao Paulo Branch Office

Praca Amadeu Amaral 27,
Primeira Andar, Conj. 11, 12, 13, 14
Liberdade, Sao Paulo, Estado de
Sao Paulo, CEP : 01327-010, Brasil
Phone: +55-11-283-2511
Fax: +55-11-288-6940

Data Lab S.R.L

Edif. Ayfra, Pdte. Franco y Ayolas
Asuncion, Paraguay
Phone: +595-21-443-046
Fax: +595-21-441+935

Electro-Impex S.A.

P.O. Box 620-1000, San Jose, Costa Rica
Phone: +506-2-31-5701
Fax: +506-2-31-6531

Electronica 2000, S.A. DE C.V.

Bldv. Adolfo Lopez Mateos No.2016, Col.
Tiacoapac, Del. Lopez Mateos, 01010,
Mexico D.F.
Phone: +525-662-8800
Fax: +525-662-5862

Electronic Engineering S.A.

Carretera de Circunvalacion, Sabanilla, Av
Novena, San Jose, Costa Rica
Phone: +506-2-25-8793
Fax: +506-2-25-1286

HDM Elquitectnica Cia. Ltda., Equitronics S.A.

Av. Republica de El Salvador, No.880,
Edificio, Almirante Colon 4to piso,
Quito, Ecuador
Phone: +593-9-704890
Fax: +593-2-48-2627

KRM Ingenieria Socias.

Viamonte 377,7° Piso 1053 Buenos Aires,
Argentina
Phone: +54-1-311-4165
Fax: +54-1-311-2297

SI Ltda.

E. Conchy Y Toro 65, Casilla 51888,
Santiago, Chile
Phone: +56-2-696-7534
Fax: +56-2-696-9665

Radiocom S.A.

Carrera 21 No.85-71, Conmutador
6100077, Santafe de Bogota, Columbia
Phone: +57-1-218-2054
Fax: +57-1-610-3272

Radiocomunicaciones cruz C.A.

Avda La Colina QTA. Elison, URB Colina
De Los Caobos, Caracas, Venezuela
Phone: +58-2-793-2322
Fax: +58-2-793-3429

Sakata Ingenieros S.A.

Av. Canaval Moreyra 840, Lima 27, Peru
Phone: +51-1225-7555
Fax: +51-1224-8148

Suministros Industriales S.A.

Casa 102, Calle 68 Este,
San Francisco, Balboa, Panama
Phone: +507-270-2328
Fax: +507-270-2329

Cabonorte S.A.

Colonia 1900, ESC. 603,
Montevideo, Uruguay
Phone: +598-2-430522
Fax: +598-2-418594

Europe

Anritsu Ltd (ACUK)

200 Capability Green, Luton
Bedfordshire, LU1 3LU, United Kingdom
Phone: +44-1582-433200
Fax: +44-1582-731303

Anritsu Ltd (ACUK-Manchester)

Kansas Avenue, Langworthy Park Salford,
Manchester M5 2GL, United Kingdom
Phone: +44-161-873-8041
Fax: +44-161-873-8040

Anritsu Ltd (ACUK-Bristol)

1230 Aztec West, Almondsbury
Bristol BS12 4SG, United Kingdom
Phone: +44-1454-615252
Fax: +44-1454-618017

Anritsu Ltd (ACUK-Livingston)

Unit 1, Knightsridge Industrial Estate
Turnbull Way, Knightsridge Livingston
EH54 8RB, United Kingdom
Phone: +44-1506-436111
Fax: +44-1506-436112

Anritsu GmbH (ACDE)

Grafenberger Allee 54-56
D-40237 Düsseldorf 1, Germany
Phone: +49-211-96855-0
Fax: +49-211-96855-55

Anritsu GmbH (ACDE-Sales Center South)

An der Steinernen Brücke 1 D-85757
Karlshof, Germany
Phone: +49-8131-3825-0
Fax: +49-8131-3825-95

August 2000

Anritsu S.A. (ACFR)

9, Avenue du Québec ZA de
Courtaboeuf 91951 Les Ulis Cedex,
France
Phone: +33-1-60-92-15-50
Fax: +33-1-64-46-10-65

**Anritsu S.A. (ACFR)
(Toulouse Office)**

Bureau de Toulouse
Région Centre Sud Ouest
Phone: +33-5-62070484
Fax: +33-5-62070668

**Anritsu S.A. (ACFR)
(Toulon Office)**

Bureau de Toulon
Région Centre Sude Est
Phone: +33-4-94040264
Fax: +33-4-94040265

**Anritsu S.A. (ACFR)
(Rennes Office)**

Bureau de Rennes
Région Ouest
Phone: +33-2-99521214
Fax: +33-2-99521224

Anritsu S.p.A. (ACIT)

Via Elio Vittorini, 129
00144 Roma EUR, Italy
Phone: +39-06-509-9711
Fax: +39-06-502-2425

Anritsu S.p.A (ACIT-Milano)

C.D. Colleoni, Via Paracelso, 420041
AGRATE B.ZA(MI), Italy
Phone: +39-039-65-7021
Fax: +39-039-605-6396

Anritsu AB (ACSE)

BOTVID CENTER
145 84 STOCKHOLM, Sweden
Phone: +46-8-53470700
Fax: +46-8-53470730

**Anritsu AB-Norway Branch
Office (ACNO)**

Leangbukta 40 1370 Asker, Norway
Phone: +47-66-901190
Fax: +47-66-901212

**Anritsu AB-Finland Branch
Office (ACFI)**

Piispanportti 9 FIN-02240 Espoo, Finland
Phone: +358-9-435-522-0
Fax: +358-9-435-522-50

**Anritsu AB-Denmark Branch
Office (ACDK)**

SOHQJ 11, DK-2690 KARLSLUNDE
Denmark
Phone: +45-46160330
Fax: +45-46155299

C.N. Rood B.V.

Cort van der Linddenstraat 11-13, 2288
EV Rijswijk ZH, The Netherlands
Phone: +31-70-3996360
Fax: +31-70-3905740

C.N. Rood SANV

Pontbeeklaan 45, 1731 Zellik, Belgium
Phone: +32-2-4668199
Fax: +32-2-4662500

ELSINCO GMBH

h.e. Strelbishte, str. Kotelnski Prohod, bl.
96/6/14, BG-1408 Sofia, Bulgaria
Phone: +359-2-58-61-31
Fax: +359-2-58-16-98

ELSINCO Praha Spol.

Novedvorska 994, CZ 142 21 Praha
4-Branik, Czecho Republic
Phone: +42-2-49-66-89
Fax: +42-2-49-54-83

ELSINCO Budapest KFT

Pannonia utca 8. IV/I.
H-1136 Budapest, Hungary
Phone: +36-1-269-18-50
Fax: +36-1-132-69-27

ELSINCO Polska Sp. Z.O.O

ul. Dziennikarska 6/1, PL 01 605
Warszawa, Poland
Phone: +48-22-39-69-79
Fax: +48-22-39-44-42

ELSINCO Bratislava Spol. s.r.o.

Kudlakova 4, SK 844 15 Bratislava,
Slovakia
Phone: +42-7-784-165
Fax: +42-7-784-454

G'Amungason Co.

Skulagata 40, 101 Reykjavik, Iceland
Phone: +354-1-677887
Fax: +354-1-625045

GMP S.A.

Av. des Baumettes 19, CH-1020 Renens
1 Lausanne, Switzerland
Phone: +41-21-6348181
Fax: +41-21-6353295

Instrutek Oeriferi A/S

Christiansholmsgade DK-8700 Horsens,
Denmark
Phone: +45-75-611100
Fax: +45-75-615658

Kostas Karayannis SA

58, Kapodistriou str., GR-142 35 Nea Ionia,
Athens, Greece
Phone: +30-1-680-0460-4
Fax: +30-1-685-3522

Omnitecnica S.A.

Estrada Alfragide 2700 Amadora, Portugal
Phone: +351-1-471-55-17
Fax: +351-1-471-36-10

Pema Ltd.

Doromiskin, Dundalk, Co. Louth, Ireland
Phone: +353-42-72899
Fax: +353-42-72376

Unitronics S.A.

Plaza Espana 18, Torre de Madrid,
Pl. 12-ofc. 9, 28019 Madrid, Spain
Phone: +34-1-5425204
Fax: +34-1-5591957

Wien CHALL GMBH

Krichbaumgasse 25, 1120 Wien, Austria
Phone: +43-1-811-55140
Fax: +43-1-811-55180

Asia, Pacific and Africa

Anritsu Private Ltd (ACSG)

6, New Industrial Rd., #06-01/02
Hoe Huat Industrial Building
Singapore 536199
Phone: 65-282-2400
Fax: 65-282-2533

Anritsu Company Ltd (ACHK)

Suite 719, 7/F., Chinachem Golden Plaza,
77 Mody Road, Tsimshatsui
East, Kowloon, Hong Kong
Phone: +852-2301-4980
Fax: +852-2301-3545

**Anritsu Company Incorporated
(ACTW)**

6F, 96, Sec. 3, Chien Kou North Rd.
Taipei, Taiwan
Phone: +886-2-2515-6050
Fax: +886-2-2509-5519

**Anritsu Corporation, Ltd (ACKR)
Head Office**

14F Hyunjuk Bldg. 832-41,
Yeoksam-dong, Kangnam-ku,
Seoul, Korea
Phone: +82-2-553-6603
Fax: +82-2-553-6604-5

Anritsu Proprietary Ltd (ACAU)

Unit 3, 170, Forster Rd., Mt. Waverley
Victoria 3149, Australia
Phone: +61-3-9558-8177
Fax: +61-3-9558-8255

Anritsu Proprietary Ltd (ACAU)

Suite 304/2 Rowe Street Eastwood
NSW 2122, Australia
Phone: +61-2-9874-9044
Fax: +61-2-9874-9920

August 2000

**Anritsu Corporation
Beijing Liaison Office**

Room No.1515, Beijing Fortune Bldg. 5
Dong-San-Huan-Bei-Lu Chao-Yang
District Beijing 100004, P.R. China
Phone: +86-10-6590-8230-9234
Fax: +86-10-6590-8235

**Anritsu Corporation
Shanghai Liaison Office**

No.511 Shanghai Jing Tai Building
No.58, Mao Ming Nan Rd. Shanghai
200020 P.R. China
Phone: +86-21-6415-5137
Fax: +86-21-6472-6577

**Anritsu Company Ltd
Guangzhou Representative Office**

Room 720, 7/F., Dongshan Plaza,
69 Xian'Le Road Central,
Guangzhou 510095 P.R. China
Phone: +86-20-8732-2231
Fax: +86-20-8732-2230

**Anritsu Corporation
New Delhi Liaison Office**

Room No. 508, Prakash Deep,
7 Tolstoy Marg, New Delhi-110001, India
Phone: +91-11-331-9133
Fax: +91-11-371-3948

**Associated Electric Trading
Corp.**

Zia Chambers, 25 McLeod Rd., Lahore,
Pakistan
Phone: +92-42-722-1716
Fax: +92-42-7221456

Chris Radiovision Ltd.

Kouloumbria Building, 23 Creta Street,
P.O. Box 1989, Nicosia, Cyprus
Phone: +357-2-466121
Fax: +357-2-365177

**Electronic Equipment
Marketing Co.**

P.O. Box 3750, Riyadh 11481,
Saudi Arabia
Phone: +966-1-4771850
Fax: +966-1-4785140

Etessa (Pty) Ltd.

1st Floor Montrose Place, Waterfall Park,
Beldker Rd., Midrand, South Africa
Phone: +27-11-315-1366
Fax: +27-11-315-2175

Gliza Systems Engineering

2 El Mesaha Square, Dokki A.R.E.,
P.O.Box 1913, Cairo 11511, Egypt
Phone: +20-2-349-0140
Fax: +20-2-360-9932

Infotechs Ltd.

23-1, Jaya Rd., Colombo 4, Sri Lanka
Phone: +94-1-580088
Fax: +94-1-584644

**Inter Muhendislik Danismanlik
ve Ticaret A.S.**

Farabi Sokak No: 24/14
Cankaya-06680 Ankara, Turkey
Phone: +90-312-4277792
Fax: +90-312-4277937

**Jasmine Telecom
Systems Co., Ltd.**

333 Lakai Plaza 6th Floor, Tower 2,
Chaengwatana Rd., Donmuang, Bangkok
10210, Thailand
Phone: +66-2-576-0200
Fax: +66-2-576-0420

Meera Agencies (P) Ltd.

A-23 Hauz Khas New Delhi 110 016, India
Phone: +91-11-685-3959
Fax: +91-11-685-2275

**UAE
Utmost Electronics Trading
(L.L.C.)**

P.O. Box 41175 Abu Dhabi, U.A.E.
Phone: +971-2-768909
Fax: +971-2-768907

Martwell Electronics Pvt., Ltd

3rd Floor, Francis House, Stanley Avenue,
P.O. Box 1737, Harare, Zimbabwe
Phone: +263-4-793578
Fax: +263-4-737956

Mandeno Electronic Equip. Co.

483 Mt. Eden Rd. Mt. Eden,
Auckland 1003, New Zealand
Phone: +64-9-630-7871
Fax: +64-9-630-1720

**National Projects and
Technology Co. L.L.C**

P.O. Box 97, Wadi Al Kabir, Postal Code 117,
Sultanate of Oman
Phone: +968-791704
Fax: +968-791697

**O'Connors Engineering
& Trading (Malaysia) Bhd**

3rd Floor, Wisma Siong Huat,
Lot 13, Jalan 51A/223
46100 Petaling Jaya,
Selangor Darul Ehsan, Malaysia
Phone: +60-3-757-2828
Fax: +60-3-757-7871

P.T. Subur Sakti Putera

Jalan Mui No.32, Jakarta 10150,
Indonesia
Phone: +62-21-3803644
Fax: +62-21-3845043

Qatar Communications Ltd.

P.O. Box 2481, Doha, Qatar
Phone: +974-424347
Fax: +974-324777

Trading and Agency Services

P.O. Box 1884, Doha, Qatar
Phone: +974-432212
Fax: +974-422255

Rajab & Silsilah & Co.

P.O. Box 203 Jeddah 21411, Saudi Arabia
Phone: +966-2-8810008
Fax: +966-2-8610558

**Saritsu International Trading
Corporation**

50B ODC International Plaza
Condominium, 219 Salcedo St., Legaspi
Village, Makati, Metro Manila, Philippines
Phone: +63-2-816-2646
Fax: +63-2-815-0986

Sedel

24, 26, Bd, Resistance, Casablanca,
Morocco
Phone: +212-2-302444
Fax: +212-2-449311

Superior Electronics Associated

B-98 Block H, North Nasimabad, Karachi-
33, Pakistan
Phone: +92-21-613655

Tareq Company

P.O. Box 20506 Safat, 13066 Safat, Kuwait
Phone: +965-2336-100
Fax: +965-2437-700

Tech-Cent Ltd.

Haarad St. No.7, Ramat Haahayal,
Tel-Aviv 69710, Israel
Phone: +972-3-6478563
Fax: +972-3-6478334

Test

Sehit Adem Yavuz Sokak No.6/17,
Kizilay-Ankara, Turkey
Phone: +90-41-71086
Fax: +90-41-74384

Japan

Head Office

5-10-27, Minamiazabu, Minato-ku,
Tokyo 106-8570
Phone: 03-3446-1111
Fax: 03-3442-0235

**Atsugi Factory
Measurement Solutions**

1800, Onna, Atsugi-si, Kanagawa 243-8555
Phone: 046-223-1111
Fax: 046-225-8379

August 2000

If you have any comments on this manual, please e-mail them to Manual-support@zz.anritsu.co.jp.



Artisan Scientific

QUALITY INSTRUMENTATION ... GUARANTEED

Looking for more information?

Visit us on the web at <http://www.artisan-scientific.com> for more information:

- Price Quotations
- Drivers
- Technical Specifications, Manuals and Documentation

Artisan Scientific is Your Source for Quality New and Certified-Used/Pre-owned Equipment

- Tens of Thousands of In-Stock Items
- Hundreds of Manufacturers Supported
- Fast Shipping and Delivery
- Leasing / Monthly Rentals
- Equipment Demos
- Consignment

Service Center Repairs

Experienced Engineers and Technicians on staff in our State-of-the-art Full-Service In-House Service Center Facility

InstraView™ Remote Inspection

Remotely inspect equipment before purchasing with our Innovative InstraView™ website at <http://www.instraview.com>

We buy used equipment! We also offer credit for Buy-Backs and Trade-Ins

Sell your excess, underutilized, and idle used equipment. Contact one of our Customer Service Representatives today!

Talk to a live person: 888-88-SOURCE (888-887-6872) | Contact us by email: sales@artisan-scientific.com | Visit our website: <http://www.artisan-scientific.com>