

TECHNICAL MANUAL

OPERATOR, ORGANIZATIONAL, DS, GS, AND DEPOT MAINTENANCE MANUAL

FOR

MARCONI INSTRUMENTS OA2090 WHITE NOISE TEST SET

**HEADQUARTERS, DEPARTMENT OF THE ARMY
MAY 1971**

WARNING

DANGEROUS VOLTAGE EXIST IN THE THIS EQUIPMENT. BE CAREFUL WHEN WORKING ON THE POWER ON THE POWER SUPPLY AND ASSOCIATION CIRCUITS OR ON THE 115-VOLT AC LINE CONNECTIONS.

Information in this publication has been furnished under U.S. Government contract No. DA 28-043-AMC-01693(E) and shall not be either released outside the government, or used, duplicated, or disclosed in whole or in part for manufacturer or procurement, without the written permission of Marconi Instruments, 111 Cedar Lane, Englewood, N. J. 07631

TM 11-6625-1568-15

Technical Manual)
)
No. 11-6625-1568-15)

HEADQUARTERS
DEPARTMENT OF THE ARMY
Washington, D.C. 17 May 1971

OPERATOR, ORGANIZATIONAL, DS, GS, AND DEPOT MAINTENANCE MANUAL

MARCONI INSTRUMENTS 0A2090 WHITE NOISE TEST SET

	Page
Section A	INTRODUCTION
A.1	Scope 3
A.2	Indexes of publications..... 3
A.3	Forms and records 3
Section 1	GENERAL INFORMATION
1.1	Features 4
1.2	Data summary..... 4.1
1.3	Items comprising an operable equipment 5
Section 2	OPERATON
2.1	Principles of operation..... 6
2.2	Preparation for use..... 7
2.3	Controls 8
2.4	Setting up the noise generator 10
2.5	Measuring noise power ratio 11
2.6	Deriving ratio of test-tone level to noise 12
2.7	Measuring absolute noise 12

		Page
2.8	Out-of-band testing	13
2.9	Component testing	14
Section 3	TECHNICAL DESCRIPTION	
3.1	Noise Generator TF 2091	15
3.2	Noise Receiver TF 2092	16
3.3	Filters	18
Section 4	MAINTENANCE	
4.1	General	19
4.2	Fuses	19
4.3	Removing the case	19
4.4	Fitting generator filters	20
4.5	Fitting receiver filters	20
4.6	Fitting receiver local oscillator boards	21
4.7	Adjustment of presets	22
CIRCUIT DIAGRAMS		
	Circuit notes	27
	Generator circuits	28
	Receiver circuits	35
CONVERSION CHARTS		
	Fig. 4.21 Conversion chart dBm/ watts	43
	Fig. 4.22 Signal to noise ratio/ noise power ratio	43

	Page
Section 5	CALIBRATION AND TROUBLESHOOTING PROCEDURES..... 46
5.1	General 46
5.2	Equipment required..... 46
5.3	Performance checking procedures, noise generator TF2091..... 46
5.4	Performance checking procedures, noise receiver TF2092 47
5.5	Troubleshooting procedures 47
5.6	Parts location illustrations 49
Appendix A	References..... 68
B	Maintenance Allocation , 69

This technical manual is an authentication of the manufacturer's commercial literature and does not conform with the format and content specified in AR 310-3, Military Publications. This technical manual does, however, contain available information that is essential to the operation and maintenance of the equipment.

LIST OF ILLUSTRATIONS

FIGURE

- 1.1 White Noise Test Set OA2090
- 1.2 Generator Noise Band Characteristic
- 1.3 Generator Stop Band Characteristic
- 2.1 Principle of Operation
- 2.2 Connections to Equipment
- 2.3 Loop Testing of Radio Link
- 2.4 Generator Controls
- 2.5 Receiver Controls
- 2.6 Measuring Noise Power Ratio
- 3.1 Generator Block Diagram
- 3.2 Receiver Block Diagram
- 3.3 Typical Oscillator Circuit
- 3.4 Typical Band-stop Filter Circuit
- 3.5 Typical Band-pass Filter Circuit
- 3.6' Typical Low-pass Filter Circuit
- 3.7 Typical High-pass Filter Circuit
- 4.1 Generator Filter Connections
- 4.2 Receiver Filter Connections
- 4.3 Changing Receiver Filters
- 4.4 Frequency Response Testing
- 4.5 Generator Power Supply Circuit
- 4.5.1 Circuit Notes

FIGURE

- 4.6 Generator Noise Source Circuit
- 4.7 Generator Low Level Amplifier Circuit
- 4.8 Generator High Level Amplifier Circuit
- 4.9 Generator Meter Circuit
- 4.10 Generator 40 db Step Attenuator Circuit
- 4.11 Generator 11 db Step Attenuator Circuit
- 4.12 Generator Inter-unit Wiring
- 4.13 Receiver Power Supply Circuit
- 4.14 Receiver 100 db Step Attenuator
- 4.15 Receiver 11 db step Attenuator
- 4.16 Receiver Wide-band Amplifier Circuit
- 4.17 Receiver Mixer Unit
- 4.18a Receiver I-F Amplifier Circuit
- 4.18b Receiver I-F Amplifier Circuit
- 4.19 Receiver I-F Band-pass filter unit
- 4.20 Receiver Inter-unit Wiring
- 4.21 Conversion Chart dBm/Watts
- 4.22 Signal-to-Noise Ratio/Noise Power Ratio

FIGURE

- 5-1 Noise Generator TF2091, upper rear view.
- 5-2 Noise Generator, Power Supply TM7594.
- 5-3 Noise Generator, Noise Source TM7637.
- 5-4 Noise Generator, Low Level Amplifier TM7638.
- 5-5 Noise Generator. High Level Amplifier TM7639.
- 5-6 Noise Generator, Meter Circuit TM7732.
- 5-7 Noise Receiver TF2092, upper rear view.
- 5-8 Noise Receiver TF2092, bottom rear view,
showing Oscillator Unit TM7775.
- 5-9 Noise Receiver, Power Supply TM7710.
- 5-10 Noise Receiver, Wide Band Amplifier TM7671.
- 5-11 Noise Receiver, Mixer Unit TM7672.
- 5-12 Noise Receiver, Audio (LF) Amplifier TM7673.
- 5-13 Noise Receiver, Low Frequency Band-Pass Filter TM7774.
- 5-14 Noise Generator, Coarse Attenuator TM7787/1, side view.
- 5-15 Noise Generator, Coarse Attenuator TM7787/1, bottom view.
- 5-16 Noise Receiver, Fine Attenuator TM7788, bottom view.
- 5-17 Noise Receiver, Fine Attenuator TM7788 or Coarse Attenuator
TM7788/1, side view.
- 5-18 Noise Receiver, Coarse Attenuator TM7788/1, bottom view.

A. INTRODUCTION

A.1. Scope

This manual describes Marconi Instruments QA2090 White Noise Test Set. It includes installation and operations instructions, and covers operator, organizational, direct support (DS), general support (GS), and depot maintenance.

A.2. Indexes of Publications

a. Refer to the latest issue of DA Pam 310-4 to determine whether there are new editions, changes, or additional publications pertaining to the equipment.

b. Refer to DA Pam 310-7 to determine whether there are Modification Work Orders (1MWO's) pertaining to the equipment.

A.3. Forms and Records

a. Reports of Maintenance and Unsatisfactory Equipment. Use equipment forms and records in accordance with instructions in TM 38-750.

b. Report of Packaging and Handling Deficiencies. Fill out and forward DD Form 6 (Report of Packaging and Handling Deficiencies) as prescribed in AR 700-58 (Army)/NAVSUP PUB 378 (Navy)/AFR 71-4 (Air Force)/ and MCO P4030.29 (Marine Corps).

c. Discrepancy in Shipment Report (DISREP) (SF361). Fill out and forward Discrepancy in Shipment Report (DISREP) (SF361) as prescribed in AR 55-38 (Army)/NAVSUP PUB 459 (Navy) /AFM 75-34 (Air Force)/ and MCO P4610.19 (Marine Corps).

d. Reporting of Equipment Manual Improvements. Report of errors, omissions, and recommendations for improving this equipment manual by the individual user is encouraged. Reports should be submitted on DA Form 2028 (Recommended Changes to DA Publications) and forwarded direct to Commanding General, U.S. Army Electronics Command, ATTN: ANSEL-ME-NMP-EM, Fort Monmouth, New Jersey 07703.

1 GENERAL INFORMATION

1.1 FEATURES

White Noise Test Set OA 2090 permits the measurement of intermodulation products and noise in multi-channel telephone link equipment. A noise signal generated by the instrument is used to simulate full traffic conditions in any number of channels up to 2700. This signal is applied to the baseband circuit of the equipment under test and the noise in a narrow slot is compared in the loaded and unloaded states.

The instrument consists of two units: a Noise Generator type TF 2091 and a Noise Receiver TF 2092. The

generator includes a selection of high-and low-pass filters to restrict the noise to the required bandwidth and band-stop filters to create a slot within the band. The receiver has a selection of narrow band-pass filters corresponding to the generator slots and a meter and attenuator to measure the relative noise level as the generator slot is switched in and out.

OA 2090R is a rack-mounting version of the test set comprising Noise Generator type TF 2091R and Noise Receiver TF 2092R.

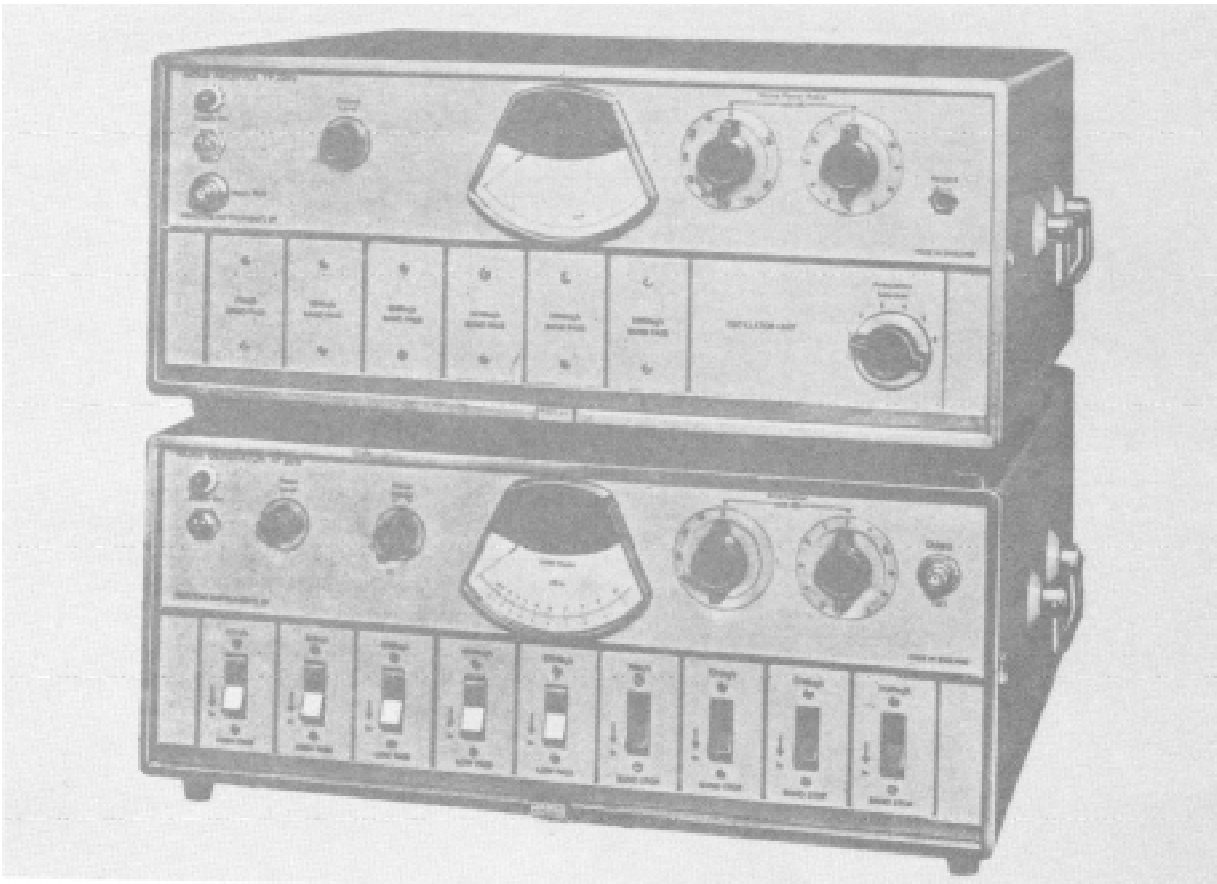

Fig. 1.1 White Noise Test Set OA 2090

1.2 DATA SUMMARY

Noise generator

Noise band characteristics:

White noise is generated over the frequency band from below 12 kc/s to above 12,388 kc/s. When a high pass filter and low pass filter are in circuit the r.m.s. noise level within the pass band does not vary by more than 1 dB. The noise is attenuated by at least 25 dB at all frequencies lower than 20% below the high pass cut off frequency, and higher than 10% above the low pass cut off frequency (except when using low pass filters above 8204 kc/s at the loading level recommended by C.C.I.R. for the corresponding bandwidth).

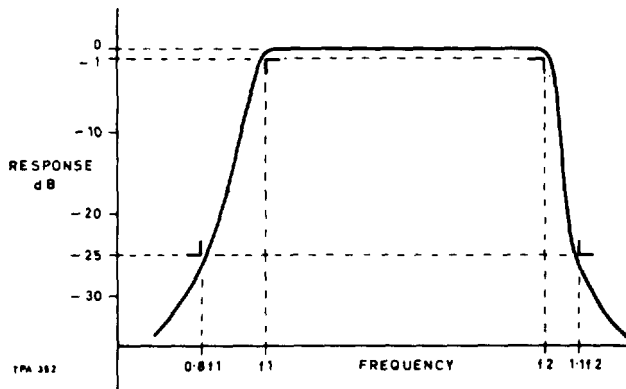

Fig. 1.2 Generator noise band characteristic

Stop band characteristics:

The noise is attenuated by more than 80 dB over a bandwidth of at least 3 kc/s, and by at least 3 dB at frequencies more than $(0.02 f_c + 4)$ kc/s from the centre frequency f_c kc/s.

Noise power output: The reference level is adjustable to above -15 dBm per kc/s of bandwidth up to a maximum total power of +20 dBm. The monitor measures total power and has two ranges, 0 to +10 dBm, and +10 dBm to +20 dBm.

Monitor accuracy: ± 1 dB between +5 and +10 dBm and between +15 and +20 dBm. ± 2 dB between 0 and +5 dBm, and between +10 and +15 dBm.

Output impedance : 75 Ω . Return loss greater than 20 dB with 6 dB or more attenuation inserted.

Output attenuator : 51 dB in steps of 1 dB and 10 dB. Accuracy: 1% of attenuator setting ± 0.1 dB.

Power requirements: 95 V to 130 V a. c. or 190 V to 260 V a. c.; 45 c/s to 500 c/s.

Consumption: 50 VA.

Dimensions:

Height	Width	Depth
7 5/8 in (19.5 cm)	18 5/8 in (47.5 cm)	17 in (43.2 cm)

Weight (without filters) : 26 lb (11.8 kg).

Weight of 1 filter: 1 lb 2 oz (480 gm).

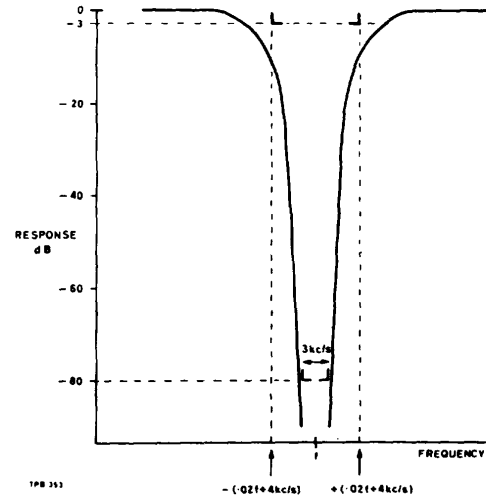

Fig. 1.3 Generator stop band characteristic

This page left blank intentionally.

Noise receiver

The instrument may be loaded with up to 6 band pass filters and 6 local oscillator boards.

Effective bandwidth: nominally 1 kc/s.

Sensitivity: Better than -115 dBm per kc/s of noise signal bandwidth for a usable meter deflection.

Input attenuator: direct reading in N. P. R. from 0 to 91 dB, with additional settings of +10 dB and +20 dB. Accuracy: 1% of attenuation value ± 0.1 dB. Impedance : 75 Ω . Return loss greater than 20 dB over N.P.R. range 0 to 75 dB.

Recorder output: suitable for use with 100 1A recorder.

Power requirements : 95 V to 130 V or 190 V to 260 V; 45 c/s to 500 c/s. Consumption: 15 VA.

Dimensions : As generator.
 Weight (without filters) : 25 lb (11.4 kg).
 Weight of 1 filter: 1 lb 2 oz (480 gm).

Overall inherent intermodulation and noise better than 75 dB(or 70 dB for measuring channels below 50 kc/ s). Measured as a 'back to back' Noise Power Ratio i.e., with the generator output connected directly to the receiver input, and with the power level not greater than that recommended by C.C.I.R. as the loading for the bandwidth in use.

Accessories supplied with OA 2090

Two BNC plugs type UG 260/U.

One telephone plug Bulgin type P38.

For bench mounting OA 2090:- Two mains leads type TM 7052.

Or, for rack mounting OA 2090R:- Two free sockets, Bulgin type P430/SE.

Accessories available

High-pass, low-pass, band-stop and band-pass filters and local oscillator boards to suit the system under test.

See table below.

Matching Transformer, 75 Ω unbal. to 150 Ω bal., type TM 5955.

Matching Transformer, 75 Ω unbal. to 140 Ω bal., type TM 5955/1.

Connecting Lead type TM 4726/260; 6 ft long with BNC plug at each end

Front-panel Cover type TM 7958/3.

1.3 Items Comprising an operable Equipment

FSN	Item	Qty	Height (in)	Depth (in)	Width (in)	Weight (lb)
	Marconi Instruments OA2090 White Noise Test Set.	1				
6625-935-6958	Noise Generator TF2091	1	7-5/8	17	18-5/8	26
6625-782-0439	Noise Receiver TF2092	1	7-5/8	17	18-5/8	25

2 OPERATION

2.1 PRINCIPLES OF OPERATION

Frequency division multiplex cable and radio relay systems may carry as many as 2700 different telephone channels with a 4 kc/ s spacing in a total bandwidth of approximately 12.5 M c/s.

In such systems it is essential that intermodulation interference in any channel, due to the telephone traffic in other channels, is kept to a minimum. This effect is produced mainly by non-linearity and phase distortion and is audible to a subscriber as interference resembling random noise.

If white noise (that is random noise of uniform frequency distribution) occupying the traffic bandwidth is applied to the system at a suitable power level, a fully loaded telephone system will be very closely simulated. Furthermore, if a filter with a very narrow stop band is interposed between the white noise source and the system, the conditions then existing will be equivalent to a fully loaded system except for one quiet channel. A receiver tuned to the quiet channel may be used to indicate the noise level produced by intermodulation of the components of the white noise occupying the remainder of the frequency band. The method outlined is closely similar to, say, a 600 channel system in which 599 channels are in use by subscribers and the remaining channel is used to listen to the noise produced by the 599 telephone conversations.

To make a measurement, white noise of the appropriate bandwidth and power level is applied from the noise generator with all filters 1 out to the system under test. The output of the system is connected to the noise receiver, which is switch tuned to the frequency of the band-stop filter it is desired to employ for producing the quiet channel.

Receiver sensitivity should be adjusted to give a convenient meter reading when the receiver input attenuator is set to maximum attenuation. The band-stop filter is switched in and attenuates the noise in a narrow portion of the generator frequency band by more than 80 dB.

To find the noise level in this narrow slot at the receiving end of the radio link or system, the noise receiver input attenuator must be adjusted to restore the original meter deflection. The difference between the initial and final attenuator settings in decibels, referred to as the noise power ratio, gives a measure of the amount of intermodulation and thermal noise produced in the system.

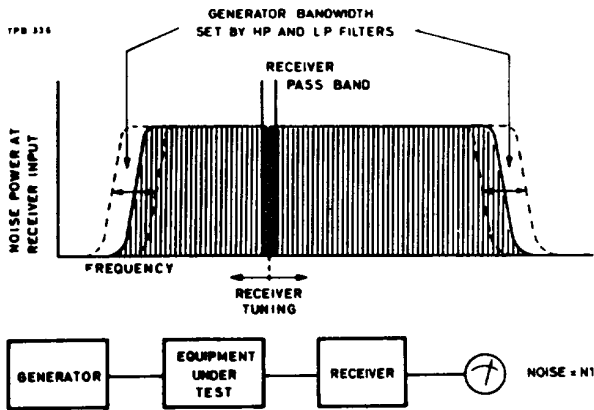

(1) Receiver samples generator noise.

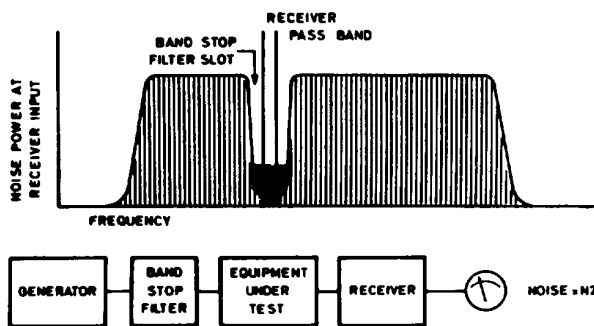

- (2) Band-stop filter switched in. Receiver samples intermodulation noise in slot.
- (3) Noise power ratio = N_1/N_2

Fig. 2.1 Principle of operation

2.2 PREPARATION FOR USE

Installation

TF 2091 and TF 2092 are electrically independent and need not be mounted close together. It is possible to arrange them at opposite ends of a radio link, assuming the operators can communicate with each other.



TPA 228

Fig. 2.2 Connections to equipment

TF 2091R and TF 2092R are rack mounting versions to fit a standard 19 inch rack.

In common with other apparatus employing semiconductor devices, the performance of the instruments may be affected if they are subjected to excessive temperatures. Therefore completely remove the plastic covers if supplied, and avoid using the instruments over, or near to, hot equipment. Keep them well away from transmitter r. f. output fields.

Power supply

Normally the test set is supplied with the mains selector switch on each instrument set for supply voltages within the range 190 to 260 V. For input voltages in the range 95 to 130 V the selector switch on the rear panel must be moved to its other position. Do this by unscrewing the plate securing the switch button, pressing the switch to the correct position, reversing the plate and replacing it to hold the switch in the new position. Change the mains fuses from 100 mA to 250 mA in the noise receiver, and from 1/2 A to 1 A in the noise generator for use on the lower voltage range.

Attach a suitable 3-pin plug to the mains lead, noting that the wires have the standard colour coding:

Connection	Colour	Sleeve
Line (phase)	Blue	
Neutral	Black	Black with white 'N'
Earth (ground)	Yellow/green	Yellow with green earth symbol

Mechanical meter zero

If necessary adjust the meter zero with the supply switched off, by small adjustments to the screw above the meter window.

Connecting to the equipment under test

The test set is designed for use with equipment of 75Ω impedance and is fitted with BNC sockets which mate with free plugs type UG-260/U. It is essential that 75Ω cable be used.

Connect the generator OUTPUT socket to the input of the equipment under test and the output of the equipment to the INPUT socket of the receiver. When making tests on a link system the generator may have to be remote from the receiver, in which case the test procedure requires two operators with intercommunication. Alternatively the 'go' and 'return' circuits can be looped so that the generator and receiver are on the same site - see Fig. 2.3.

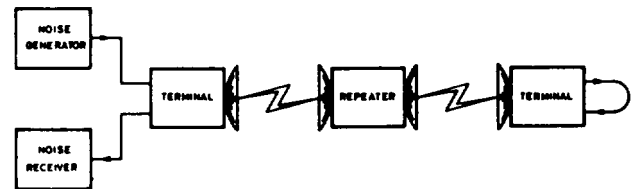

TPB 228

Fig. 2.3 Loop testing of radio link

The apparatus may be used immediately upon switching on, but maximum stability is not reached for several minutes.

2.3 CONTROLS

Generator

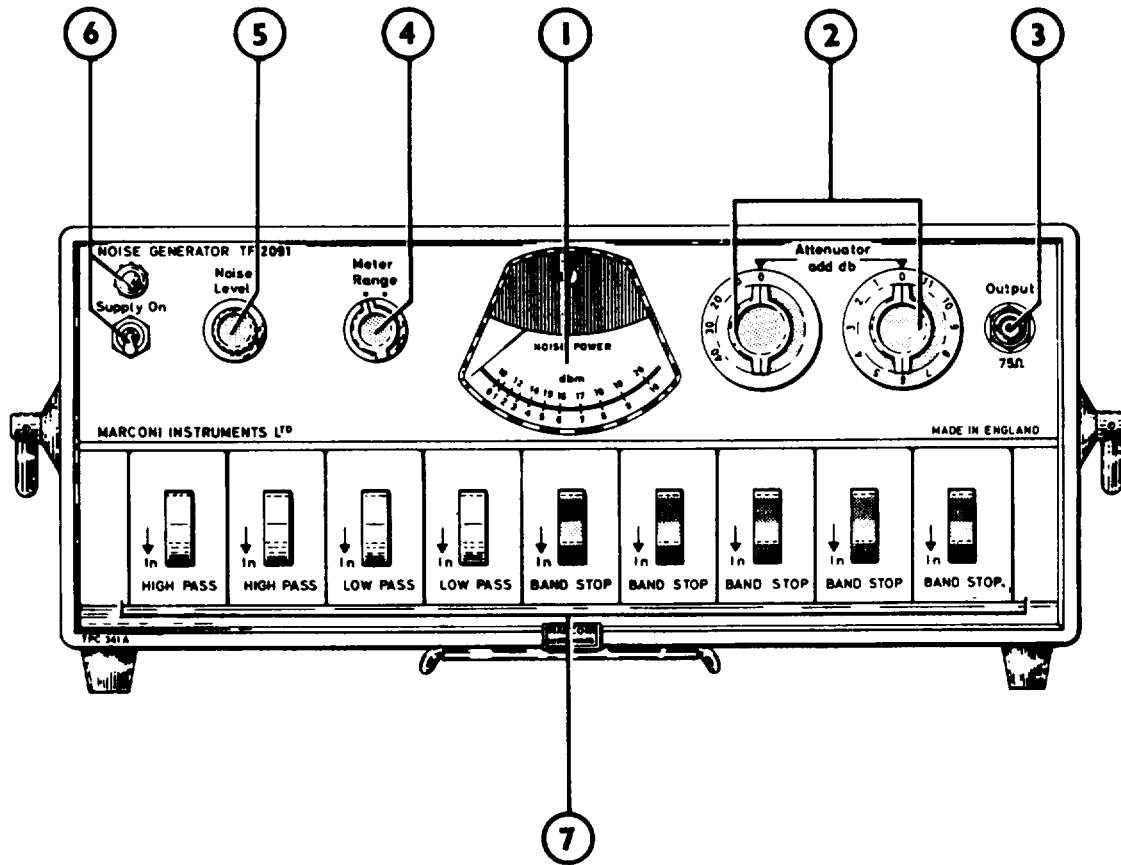

Fig. 2.4 Generator controls

- (1) METER. Indicates available power in decibels relative to 1 mW in a 75Ω load at the OUTPUT socket. -Actual power is given by the meter reading minus the sum of the ATTENUATOR dial readings.
- (2) ATTENUATOR controls. Adjust output in 10 dB and 1 dB steps.
- (3) OUTPUT socket. BNC type.
- (4) METER RANGE switch. Use black position with black scale on meter for setting standard power outputs up to 10 dBm. Use red position with red scale for 10 to 20 dBm outputs.
- (5) NOISE LEVEL control. Adjusts the output level of the noise source. Set to give the standard power output appropriate to the bandwidth.
- (6) SUPPLY switch and pilot lamp.
- (7) FILTERS. High-pass and low-pass (grey switches) determine noise band-width; band-stop (red) create slots in the noise band.

Receiver

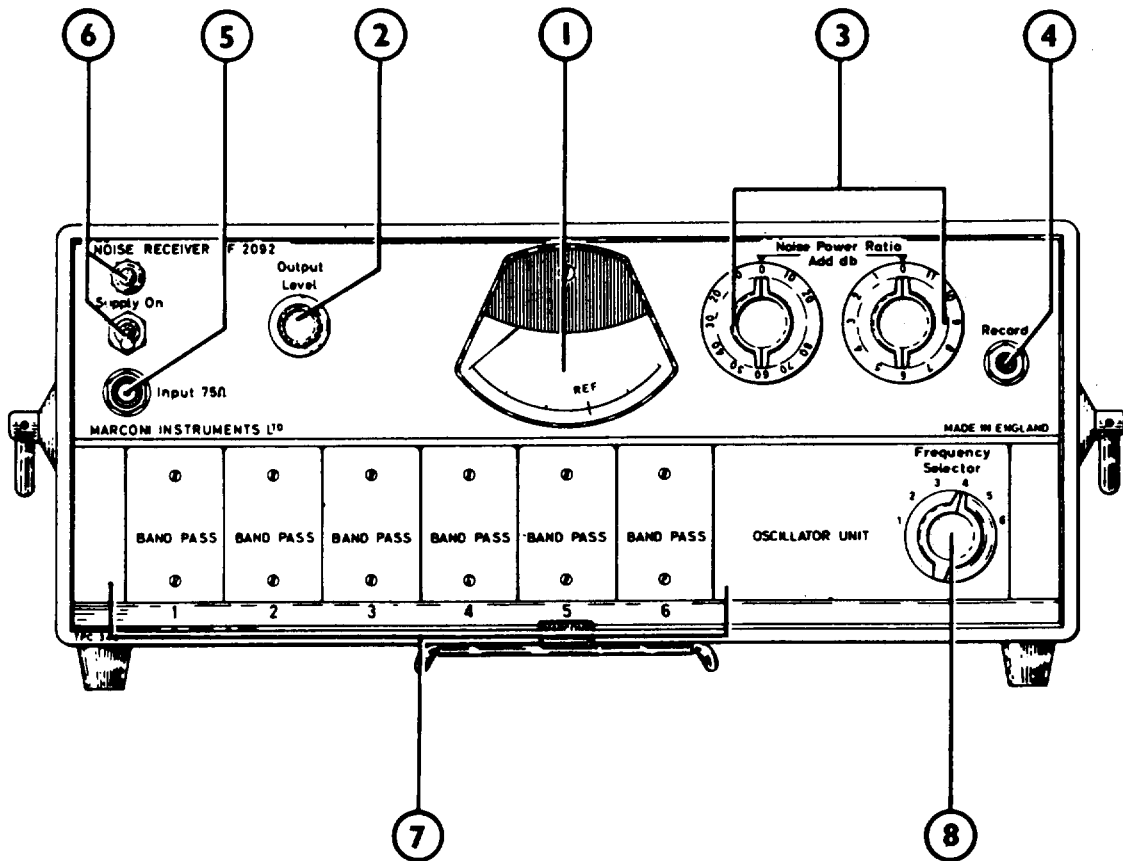

Fig. 2.5 Receiver controls

(1) METER. Indicates reference level for noise power ratio measurement.

(2) OUTPUT LEVEL control. Adjusts receiver gain to give standard meter reading with generator band-stop filters out and NOISE POWER RATIO attenuators at 0 dB.

(3) NOISE POWER RATIO attenuator controls. Adjust to restore standard meter reading with generator band-stop filter in.

(4) RECORD jack. Accepts 2-pole telephone plug for connection to external indicator or recorder.

(5) INPUT socket. BNC type.

(6) SUPPLY switch and pilot lamp.

(7) FILTERS determine receiver pass-band centre frequency, which must coincide with generator band-stop filter frequency.

(8) FREQUENCY selector switch. Selects the band-pass filter and oscillator with the corresponding number.

2.4 SETTING UP THE NOISE GENERATOR

The output of the noise generator must be terminated in 75n when the instrument is being set up. Normally the equipment under test will provide the termination.

Switch in a high-pass and a low-pass filter to give the noise bandwidth required by the equipment under test as shown in Table 2.1. Do not use more than one high-pass and one low-pass filter at a time.

Switch out all the band stop filters, and turn both ATTENUATOR controls to 0. Set the METER RANGE switch and NOISE LEVEL control to obtain a meter reading †

corresponding to the generator bandwidth see Table 2.1. Alternatively, to improve the v.s.w.r. at the generator OUTPUT socket, the required output level can be set up by turning the NOISE LEVEL control to a somewhat higher level and removing the surplus amount by means of the ATTENUATOR controls; the output level is then given by the meter reading minus the sum of the ATTENUATOR readings.

If a non-standard bandwidth is used adjust for a meter reading corresponding to the nearest standard bandwidth or for the reading derived from the formulas.

A lower noise power level is often used for testing purposes, typically -45 dB relative to the system zero reference level. But for systems using more than 300 channels the output must always be set to at least 10 dBm as shown on the meter (red range), since the high frequency performance of the meter circuit is better on the red range; lower output levels can then be obtained by using the ATTENUATOR controls.

† This represents the correct power for applying to a point of zero reference level in the system and is derived from the expression:

$$(-15 + 10 \log_{10}N) \text{ dBm for 240 channels or above,}$$

$$(-1 + 4 \log_{10}N) \text{ dBm for 12 to 240 channels, where N equals the number of channels.}$$

Note : For most purposes the peak to r.m.s. ratio of white noise is not important. Sometimes statistical studies may be made, requiring a ratio of at least 8 dB. In these cases, where a wide dynamic range is required, the noise generator meter indication should not exceed 15 dBm. Above this level an increasing degree of peak clipping takes place.

TABLE 2.1 CCIR recommended levels

System capacity. channels	Generator bandwidth kc/s	Meter indication, dBm0*m, set by NOISE LEVEL control	METER RANGE switch setting	Output power dBm per kc/s
12	12-60	3.3	BLACK	-13.5
24	12-108	4.5		-15.3
36	12-156	5.2		-16.4
48	12-Z04	5.7		-17.1
60	12-252	6.1		-17.7
	or 60-300			
120	60-552	7.3		-19.6
240	60-1052	8.8		-21.2
300	60-1300	9.8		-21.1
600	60-2540	12.8		-21.1
960	60-4028	14.8	RED	-21.2
	or 316-4188			-21.1
1800	316-8204	17.6		-21.4
2700	316-1Z388	19.3		-21.5

*dBm0 means dB relative to zero reference level (single channel test tone level)

2.5 MEASURING NOISE POWER RATIO

When the test set has been connected and adjusted as described in the preceding Sections, noise power ratio at any of the band-stop filter frequencies in the bandwidth of the generator can be measured as follows:

- (1) Set the receiver NOISE POWER RATIO control to 0 dB.
- (2) Switch out all the generator band-stop filters.
- (3) Adjust the ATTENUATOR controls on the generator so that the level of noise output corresponds to the level of multi-channel signal to be simulated. The noise output is given by subtracting the sum of the ATTENUATOR readings from the generator meter reading as described in Section 2.4.
- (4) Turn the receiver FREQUENCY SELECTOR switch to suit the frequency at which the noise-power ratio is to be measured. The BAND SELECTOR switch positions are numbered to correspond to the six band-pass filter positions.
- (5) Adjust the receiver OUTPUT LEVEL to bring the receiver meter reading to the reference mark.
- (6) Switch IN the generator band-stop filter for the frequency selected in (4). The meter reading on the receiver should drop. (Any change of generator meter reading that may occur should be disregarded, but when testing low-capacity systems of less than 60 channels see below.)
- (7) Adjust the receiver NOISE POWER RATIO controls so that the receiver meter indication is restored to the reference mark.
- (8) The sum of the NOISE POWER RATIO controls now indicates the result of the measurement. The noise-power ratio of an equipment or link, measured in this way, is the ratio of (i) the portion of the noise representing a multi-channel signal that occurs in a narrow bandwidth, to (ii) the inherent and intermodulation noise in the same band-width when signals are not applied in that band but are applied over the remainder of the multi-channel frequency range. Part (i) of the ratio also includes inherent and intermodulation noise, but this is usually negligible in comparison with the noise representing the signal.

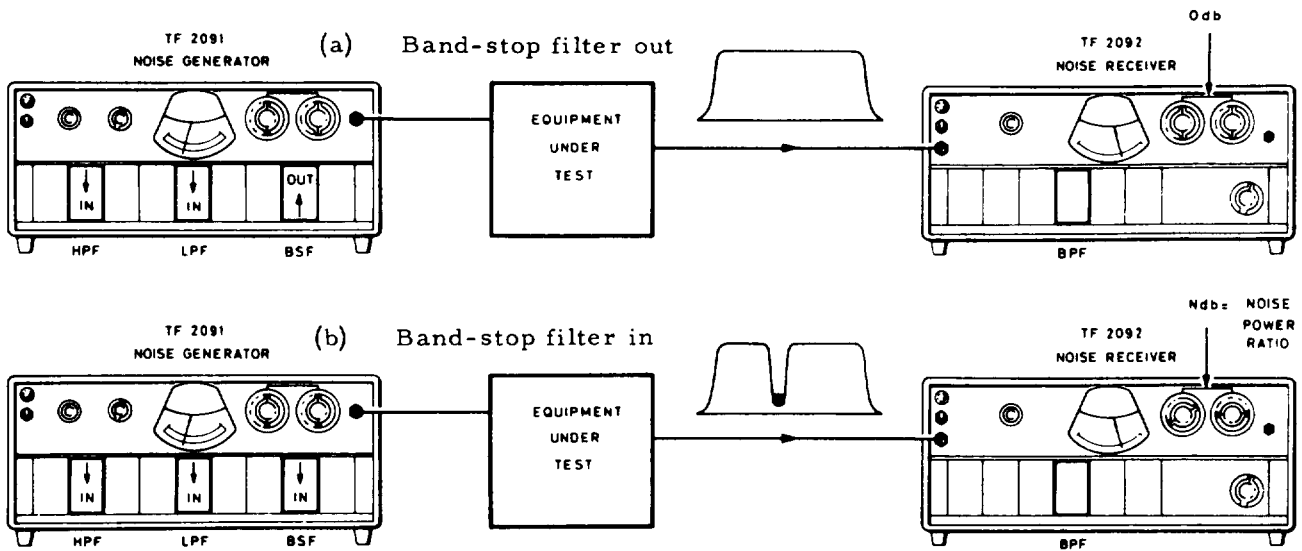

TPC 359

Fig. 2.6 Measuring noise power ratio

Low capacity system testing

Where a band-stop filter is switched in the meter reading drops, owing to the loss of 'slot' power. If the same system input power (i.e., frequency deviation) is required the NOISE LEVEL should be turned up to the original indication; the noise power per channel will then be increased, possibly above a desirable level.

Measurement with other input levels

In step (1) above, the receiver NOISE POWER RATIO controls are set to 0 dB. This, which is a general recommendation, is good practice since a small input to the receiver mixer assists in ensuring that the noise power ratio of the test set alone is high. However, if the level of output from the equipment under test is low, it will be necessary to employ an advanced setting of receiver OUTPUT LEVEL in (5). Inherent noise in the receiver may then contribute so much to the meter reading that little drop in meter indication occurs when the filter is inserted in (6). In turn, this leads to less precision in the adjustment in (7). In these circumstances, you may commence in (1) with more than 0 dB reading (black) so that a higher ratio of noise signal to inherent receiver noise is obtained. It will then be necessary in (8) to subtract this initial reading from that obtained in (7) to obtain the noise power ratio.

Measurement with high input level

The receiver should not be operated with the OUTPUT LEVEL control in a critical anti-clockwise position, i.e. at almost minimum gain.

If the receiver input signal is very large, switch the NOISE POWER RATIO controls to the red 10 or 20 dB positions. Remember to add the red figures to the total in step (7).

Use of RECORD output

Although the meter is the primary means of observing output on the receiver, the RECORD jack on the front panel permits the use of a recorder or headphones to monitor the output. High impedance headphones are

recommended for use here, and may be employed to detect spurious signals such as hum or r.f. interference which may be affecting the meter reading. The d.c. component at the jack, available for a recorder, is up to 2 V d.c.e.m.f. at a source impedance of several k Ω ; a low-speed low-impedance recorder requiring 100 μ A or less is recommended.

2.6 DERIVING RATIO OF TEST-TONE LEVEL TO NOISE

It is possible to convert the noise power ratio, measured as in Section 2.4, into a ratio of test-tone level to noise (inherent and intermodulation) in a single channel. (This is a baseband measurement only. The multiplex noise must be checked separately and added on, to get the figure for the system.)

Taking the multi-channel signal power which the generator has been adjusted to simulate, the proportion of it falling in the width of one channel is calculated. By expressing this in dB below test-tone level and adding it to the noise-power ratio, the level of inherent and intermodulation noise in one channel below test-tone level is obtained. Expressed as it is, in dB, this is the required ratio. Thus the ratio of test tone level to psophometrically weighted unwanted noise in one channel is given by :

$$N + 10 \log (A/B) - P + 2.5 \text{ decibels where}$$

N = noise power ratio in dB,

A = bandwidth of multi-channel signal in kc/s,

B = width of one channel in kc/ s,

P = multi-channel signal power simulated by the generator in dB above test-tone level.

2.7 MEASURING ABSOLUTE NOISE

The receiver can be used to measure noise power in dBm per kc/s if it is first calibrated against the known power from the generator as follows:

- (1) Turn the generator ATTENUATOR controls and the receiver NOISE POWER RATIO controls to 0 dB and connect the generator directly to the receiver.

- (2) On the generator, switch in a high-pass and a low-pass filter to give the noise bandwidth required by the system under test - as shown in Table 2.1 - and adjust the generator output to the corresponding level.
- (3) On the receiver, switch to the frequency at which measurement is to be made and adjust the OUTPUT LEVEL control to make the meter read at its reference mark. This reading now corresponds to the power per kc/s as shown in the last column of Table 2.1. Do not subsequently move the OUTPUT LEVEL control.

To make a measurement:-

- (4) Remove the generator and connect the receiver to the equipment under test. Restore the receiver meter reading to the reference mark by resetting the NOISE POWER RATIO controls. The new setting subtracted from the reference level found in (3) indicates the noise power in dBm per kc/s. (This can be expressed in other forms using the dBm conversion table in Fig. 2.21.

Example:

To measure noise level at 270 kc/s in a 600-channel system, switch in generator filters of 60 kc/s (h-p) and 2540 kc/s (1-p) and a receiver filter of 270 kc/s. Standardize the receiver against the generator - Table 2.1 shows that the reference level is -21.1 dBm per kc/s. If, when making a measurement, the new NOISE POWER RATIO setting is 46 dB the noise power in the equipment is given by $(-21.1 - 46)$ dBm per kc/s = -67 dBm per kc/s.

NOTE

When using this method to check the inherent noise in an equipment, the input to the equipment must be terminated in 75Ω . It may be convenient to use the noise generator, with its SUPPLY switch OFF, as the termination.

2.8 OUT-OF-BAND TESTING

The test set may be supplied with filters for use at out-of-band test frequencies, particularly those recommended by the C.C.I.R. which include 50, 270, 331, 607, 1499, 3200, 4715 and 9023 kc/s. This is intended to enable maintenance measurements to be made under actual traffic conditions. The method involves the measurement of noise, including intermodulation products, in narrow bands whose centre frequencies are approximately 1070 above the upper frequency limit and 10% below the lower limit of the traffic band. Measurements above the signal band are generally more sensitive to changes of thermal and intermodulation noise in the r.f. and i.f. parts of the equipment, whereas measurements below the band are more sensitive to changes in modulators and demodulators.

Before making a measurement, the receiver must be calibrated against the noise generator by a method basically similar to that described in Section 2.7. But for out-of-band testing the generator must be fitted with high-pass and low-pass filters giving a wide bandwidth that includes the out-of-band frequency. For example, if the receiver is to be calibrated for use at the 3200 kc/s out-of-band frequency, suitable filters for the generator would be 60 kc/s (high-pass) and 4028 kc/s (low-pass) giving a bandwidth of 3968 kc/s.

The calibrating procedure is as follows :-

- (1) Switch in the receiver band-pass filter corresponding to the out-of-band frequency - see Table 2.2 - and turn the NOISE POWER RATIO controls to 0 dB.
- (2) Connect the generator, with its high-and low-pass filters switched in, directly to the receiver. Adjust the generator output to a level suitable to the bandwidth (+14.8 dBm in the example above) - see Table 2.1.
- (3) Adjust the receiver OUTPUT LEVEL control to make the meter read at the

TABLE 2.2

Typical Filter Frequencies for Various System Capacities

No. Of Channels	Sand Limits		In-Band Test Channels			Out-of-Band Test Channels	
	High Pass	Low Pass	Lower	Centre	Upper	Lower	Upper
12	12 kc/s	60 kc/s	27 kc/s	40 kc/s	50 kc/s	-	-
24	12 kc/s	108 kc/s	40 kc/s	70 kc/s	105 kc/s	-	-
36	12 kc/s	156 kc/s	40 kc/s	70 KC/S	105 kc/s	-	-
48	12 kc/s	204 kc/s	40 kc/s	105 kc/s	185 kc/s	-	-
60	12 kc/s	252 kc/s	40 kc/s	185 kc/s	245 kc/s	-	-
60	60 kc/s	300 kc/s	70 kc/s	185 kc/s	270 kc/s	50 kc/s	331 kc/s
120	60 kc/s	552 kc/s	70 kc/s	270 kc/s	534 kc/s	50 kc/s	607 kc/s
240	60 kc/s	1,052 kc/s	70 kc/s	534 kc/s	1,002 kc/s	50 kc/s	-
300	60 kc/s	1,300 kc/s	70 kc/s	534 kc/s	1,248 kc/s	50 kc/s	1,499 kc/s
600	60 kc/s	2,660 kc/s	70 kc/s	1,248 kc/s	2,438 kc/s	50 kc/s	3,200 kc/s
960	60 kc/s	4,028 kc/s	70 kc/s	2,438 kc/s	3,886 kc/s	50 kc/s	4,715 kc/s
960	316 kc/s	4,188 kc/s	534 kc/s	2,438 kc/s	3,886 kc/s	270 kc/s	4,715 kc/s
1,200	316 kc/s	5,564 kc/s	534 kc/s	3,888 kc/s	5,340 kc/s	-	-
1,800	316 kc/s	8,204 kc/s	534 kc/s	3,886 kc/s	8,002 kc/s	-	-
2,700	316 kc/s	12,388 kc/s	534 kc/s	3,886 kc/s	12,150 kc/s	-	-

reference mark. This reading now corresponds to a power of 14.8 dBm per 3968 kc/s of bandwidth, or - 21 dBm per kc/s. Do not subsequently alter the setting of the control.

To make a measurement :-

- (4) Remove the generator and connect the receiver to the system under test. A band-stop filter at the out-of-band frequency should be connected in the input to the system to ensure that the out-of-band power at the receiver input is coming only from the system under test.
- (5) Restore the meter reading to the reference mark by turning up the NOISE POWER RATIO controls. The out-of-band noise power at the receiver input is given by - (N + 21) dBm per kc/s, where N is the new NOISE POWER RATIO setting.

This noise power may be related to the traffic power in the signal band to give a value for signal to noise ratio. The range of the receiver attenuator permits noise power ratios as great as 111 dB to be measured to an accuracy of ± 1 dB, while the receiver sensitivity is not less than - 115 dBm per kc/s.

2.9 COMPONENT TESTING

The high output of the noise generator provides opportunities for testing video equipment, passive apparatus etc. in conjunction with the noise receiver, an h.f. spectrum analyser or a tunable level meter.

In applications such as this the noise power ratio of the equipment under test may be nearly as good as that of the white noise test set; it is therefore important to have only one band-stop filter switched into the test set since using more than one at a time may worsen its noise power ratio.

3 TECHNICAL DESCRIPTION

3.1 NOISE GENERATOR TF2091

Noise Source TM 7637 -see Fig. 4.6

A white noise junction diode, MRZ00, is used to develop random noise with a substantially flat spectrum over the entire range of 10 kc/s to 12.5 Mc/s. The diode is reverse-biased, and a very small current from the 100 V supply flows through it, controlled by the potentiometer RV200. Noise output is amplified by the emitter follower VT200. RV201 presets the gain, and RV202 is the front panel OUTPUT LEVEL control.

Low Level Amplifier TM 7638 -see Fig. 4.7

From the noise source unit the signal passes to the low level amplifier, a five stage high gain circuit. Both the first pair and the second pair have feedback loops to improve stability and widen the frequency response. The response is flattened in production by adjustment of preset components in the feedback loops. A low impedance output is taken from the last stage, VT304, to the high- and low-pass filters.

High Level Amplifier TM 7639 -see Fig. 4.8

From the filters the noise signal is amplified by six transistors in the high level amplifier. The first pair resemble in action the high gain stages of the low level amplifier, with direct coupling and feedback; the third is a.c. coupled by C403 and is powered, with the remaining stages, from the 54 V supply. VT402, 403 and 404 are direct coupled and provide a low impedance drive for VT405. This is a power amplifier and provides the noise generator output via the coarse and fine attenuator s.

Meter Circuit TM 7732 -see Fig. 4.9

Noise output goes to the OUTPUT terminal via the band-stop filters, and its level is monitored at the output by the meter circuit. A passive network cannot be used at this point because no intermodulation, such as would be caused by a meter diode, can be allowed after the band-stop filters.

The noise output is isolated from the diode voltage doubler MR500 and 501 by the emitter follower VT500 and its associated

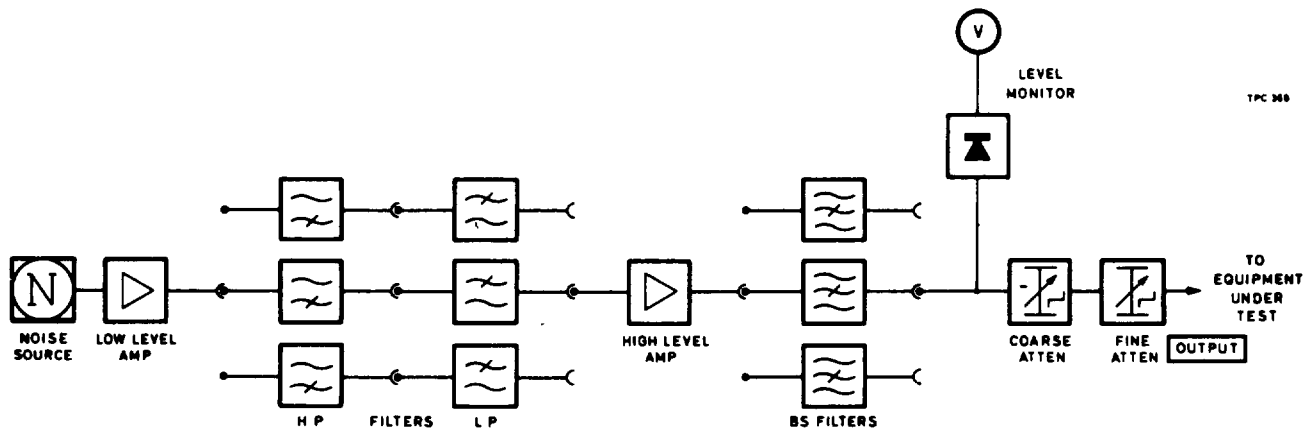

Fig. 3.1 Generator block diagram

components. Following the rectifiers are two resistive meter range circuits, either of which can be selected by the METER RANGE switch

The meter indicates true output power into the attenuator since the band-stop filters come before the meter, so no correction is required.

Power supply -see Fig. 4.5

The input transformer has two input windings which can be arranged in series or parallel by switch SB. In series supplies of 190 to 260 V can be used, and in parallel 95 to 130 V. No other adjustment is required Both input leads are fused, and a neon pilot lamp is driven from one half of the primary winding.

The secondary is centre-tapped and drives a series regulator circuit through a full-wave rectifier MR100 and MR101. The regulated output is at 54 V, and two other potentials are available; 25 V tapped from the 54 V line, and 100 V obtained by adding 45 V on to the 54 V supply. The extra 45 V comes from a half wave rectifier MR102 and three 15 V Zener diodes MIR103, 104 and 105.

VT1 is the series stabilizer, and MR106 and 107 provide a reference potential for the emitter of VT 101, the error signal amplifier. RV101 sets the output voltage level: hum and output fluctuations

pass via VT100 to the base of VT1. RV100 is adjusted for minimum ripple and RV102 adjusts the 25 V line.

Resistors are fitted across C1 and across FS3 to discharge C1 upon turning off the supply, eliminating the risk to transistors which could otherwise result when replacing the fuse.

3.2 NOISE RECEIVER TF2092

Wide Band Amplifier TM 7671 -see Fig. 4.16

After passing through the NOISE POWER RATIO attenuators and a band-pass filter determined by the FREQUENCY SELECTOR switch, the noise input from the equipment under test reaches a five stage wide band amplifier. Four stages amplify; the fifth is an emitter follower.

The first stage is designed for a low level of self-generated noise, and the last for a low impedance to drive the mixer circuit which follows. Two negative feedback loops give high stability and help to achieve the wide frequency response. The gain of the amplifier is preset to about 33 dB by RVZ00 in the second feedback loop.

Local oscillator

A wide selection of channels is available, each channel requiring its own band-

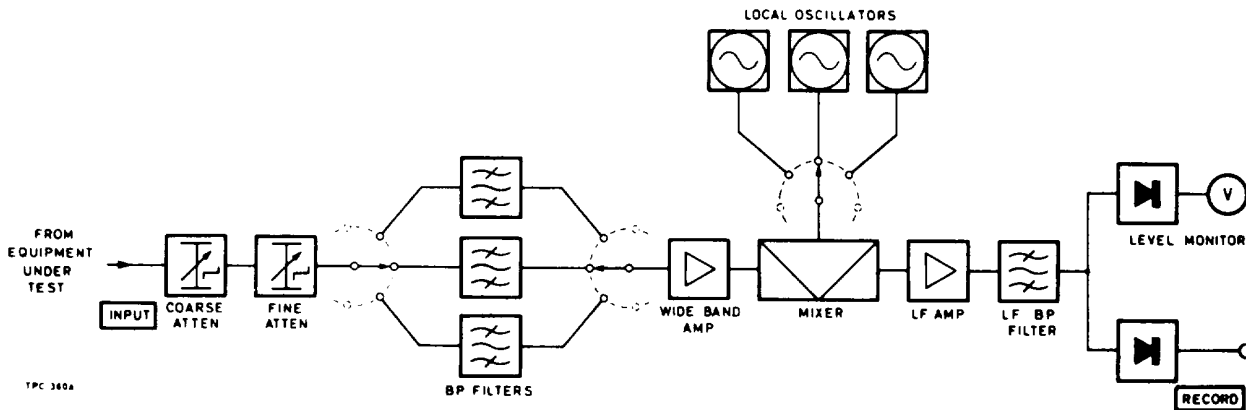

Fig. 3.2 Receiver block diagram

pass filter, band-stop filter and local oscillator board. Although the circuit

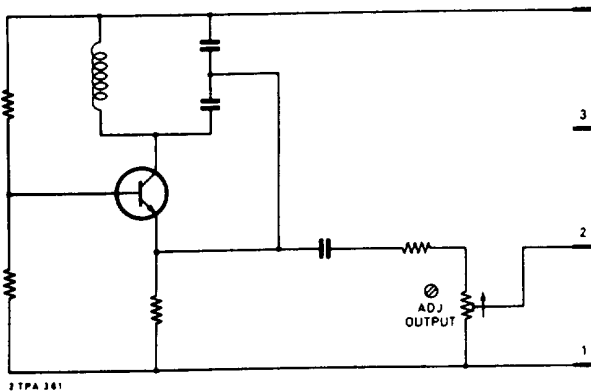

Fig. 3.3 Typical oscillator circuit

shown in the diagram is basic to all the local oscillators, six of which can be accommodated in the instrument, frequency requirements affect both circuit constants and details. The required oscillator is switched on by the FREQUENCY SELECTOR switch, which applies 25 V to plug 4 and takes the output from plug 2 to the mixer. The local oscillator is tuned to the centre frequency of the channel, so that there is no intermediate frequency and the mixer output is 1. f.

Mixer TM 7671 -see Fig. 4.17

The noise signal from the wide band amplifier enters the mixer at PL300, and encounters a high-pass filter (C302, C303 and L300). All frequencies below 10 kc/s are prevented from reaching the base of the mixer, VT300, in the interests of low hum and microphony.

The local oscillator signal, at the centre frequency of the r.f. input signal, arrives at the emitter of VT300 via SKT300 and the emitter follower VT301. RV300 adjusts the current in VT 300 for optimum mixing, and the low-pass filter (C309,C310 and L301) removes local oscillator and noise input frequencies from the output from the mixer. The low frequency output is taken from SKT301 to the 1.f. amplifier.

TM 11-6625-1568-15

L.F. Amplifier TM 7673 -see Fig. 4.18a and b

From the mixer the signal consisting only of noise sidebands goes to an 1.f. amplifier with seven stages before actuating the meter. The amplifier has a high gain, and after the third stage comes the OUTPUT LEVEL control, RV1. Between the fourth and fifth stages is a band-pass filter, transmitting only frequencies between 500 c/s and 1 kc/s. This gives an effective bandwidth to the receiver of 1 kc/ s.

Two outputs are taken from the last stage; an internal rectified voltage to the meter, and an output to the front panel RECORD jack. Headphones may be used to monitor the output from this jack, as may a meter or d.c. operated recorder, since the output contains both a.c. and d.c.

Power Supply TM 7710 -see Fig 4.13

The input transformer has two input windings which can be arranged in series or parallel by switch SB. In series, supplies of 190 to 260 V can be used, and in parallel 95 to 130 V. No other adjustment is required. Both input leads are fused, and a neon pilot lamp is driven from one half of the primary windings.

One of the two secondary windings produces 100 V d.c. from a half-wave rectifier, MR103, and a string of Zener diodes; the other half is centre-tapped, and its output is taken through MR100 and MR101 to the series regulator circuit formed by the voltage reference zener diode MR10Z and three transistors VT1, VT100 and VT101.

RV 100 is provided to allow adjustments to be made for minimum ripple, and RV101 sets the output level at 25 V.

The reservoir capacitor, C1, is fitted with a parallel resistor to discharge it when the supply is switched off - a necessary safeguard in a semiconductor instrument.

The 25 V line is fused. This fuse must not be removed or replaced until the reservoir capacitor has had time to discharge.

3.3 FILTERS

Several different types of filter are used in the white noise test set, including band-stop, band-pass, low-pass and high-pass. - Most are based on series and parallel tuned circuits, but the exact arrangement in each type depends on the frequency and the stringency of cut-off requirements, so only a general guide to their operation can be given.

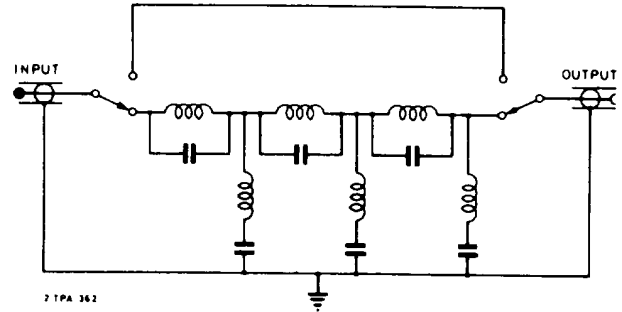

Fig. 3.4 Typical band-stop filter circuit

Band-stop

Parallel tuned circuits in series with the applied signal reject the centre frequency; acceptor circuits conduct it to earth. Both connections to the filter are switched in order to avoid stray losses when the filter is not in use. The band stop filters reject the centre frequency by about 80 dB

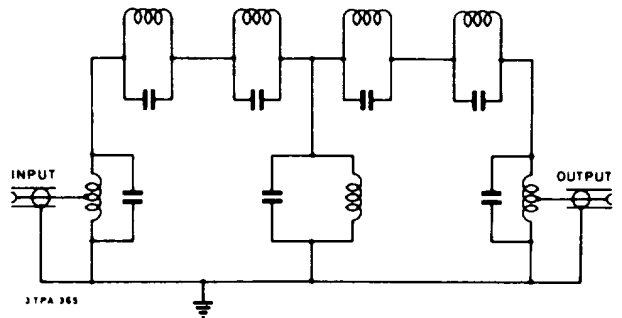

Fig. 3.5 Typical band-pass filter circuit

Band-pass

Most of the band pass filters used in the test set use series capacitors interposed between rejector circuits to earth. The example shown is a low frequency band pass filter, in which the pass band has been widened by tuning the series components to out-of-band frequencies.

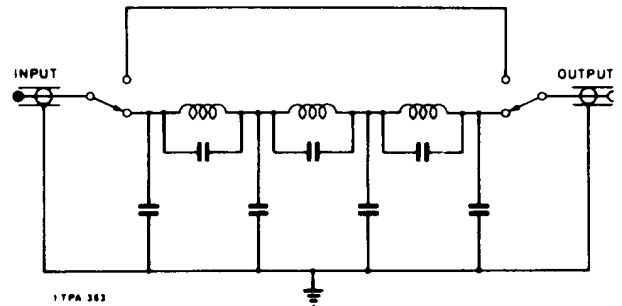

Fig. 3.6 Typical low-pass filter circuit

Low-pass

A low pass filter stops frequencies above, but passes frequencies below, its cut-off frequency. Rejector circuits in the series limb are tuned to different frequencies above cut-off.

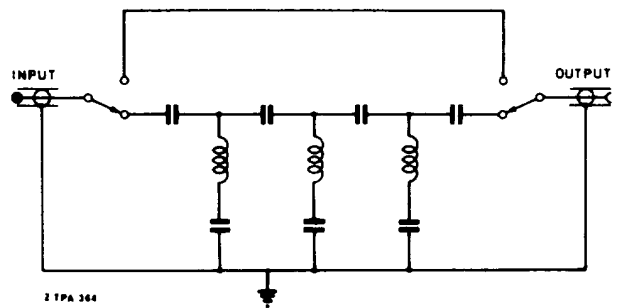

Fig. 3.7 Typical high-pass filter circuit

High-pass

All the tuned circuits in the high-pass and low-pass filters are different, each being tuned to stop unwanted signals. In the high-pass filter they are tuned to frequencies below cut-off, the overall result being the attenuation of all but the frequencies above this point.

4 MAINTENANCE

4.1 GENERAL

This section serves as a general guide to the servicing of the instruments.

Semiconductor devices are used through-out the test set, and although they have inherent long term reliability and mechanical ruggedness, they are easily damaged by overloading, reversed polarity and heat or radiation. Avoid prolonged soldering, strong r.f. Fields or short circuits. Do not use insulation testers. Always allow a few seconds for the h.t. lines to discharge before attempting any operation on the internal components.

It may be desirable after some time to clean and lubricate the switch contacts, using a mixture of benzine and light oil.

4.2 FUSES

All the fuses are set in the rear panel. The noise generator has four: two supply fuses rated at 1/2 A for 240 V or 1 A for 110 V, and two h.t. fuses, of 50 mA and + A rating.

The noise receiver has three fuses, two supply fuses of 100 mA (or 250 mA for 110 V supplies) and a 250 mA h.t. fuse.

It is not necessary to remove the case or cover to reach the fuses but it is essential to switch off the supply, unplug the supply lead and wait at least 30 seconds before fitting a new fuse.

4.3 REMOVING THE CASE

The case is held on by four 2 BA screws in the back. The rack-mounting version has top and bottom covers secured by a screw at each corner. Generator and receiver have similar covers or cases, and the bottom of the case is separately detachable by undoing six screws, four of which also secure the feet.

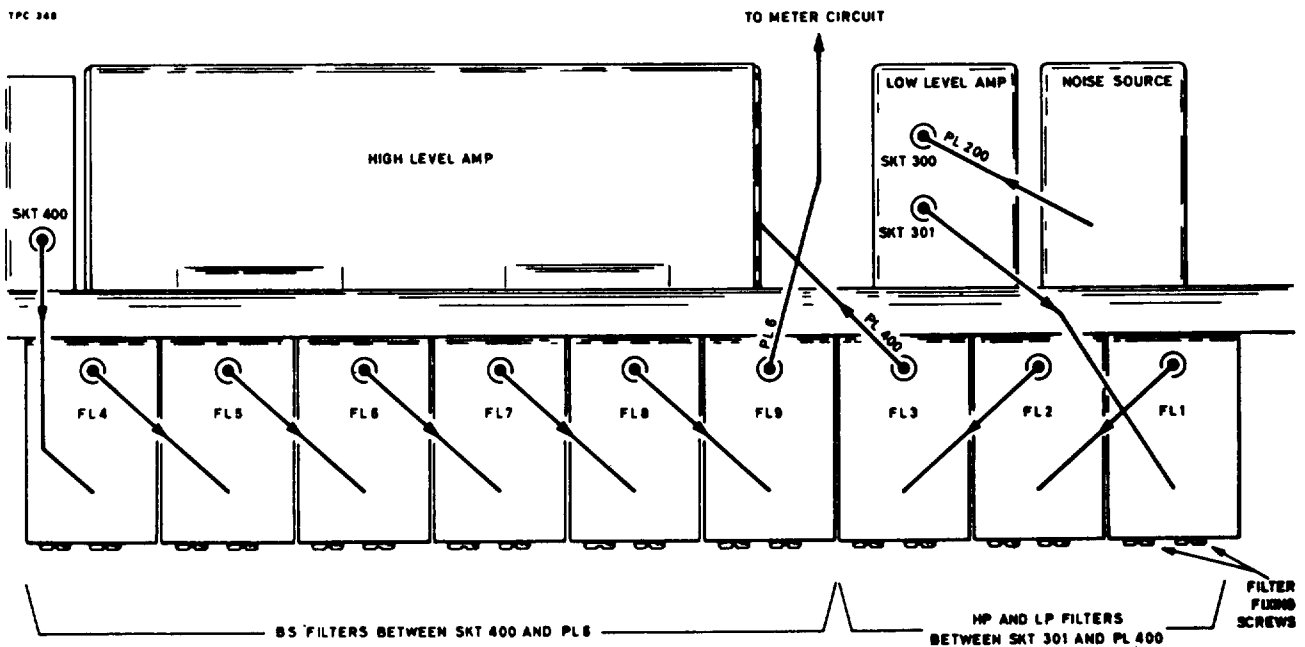

Fig. 4.1. Generator filter connections

For example, a filter fitted in No. 2 position will have leads marked '2'; the lead to its IN socket comes from the slot labeled IN, and the lead to the OUT socket from the slot labeled OUT. A filter connected the Wrong way round would not work. Note that each band-pass filter has an associated local oscillator board which must also be changed.

Attach the cable clip to one of the tapped holes in the rear panel. Never leave cables loose inside the case.

4.6 FITTING RECEIVER LOCAL OSCILLATOR BOARDS

Switch off the supply, and take out the mains plug. With the bottom panel of the case or dust-cover removed, the oscillator box is accessible. It contains the FREQUENCY SELECTOR switch, and may be opened after removing two screws from the rear end of its cover.

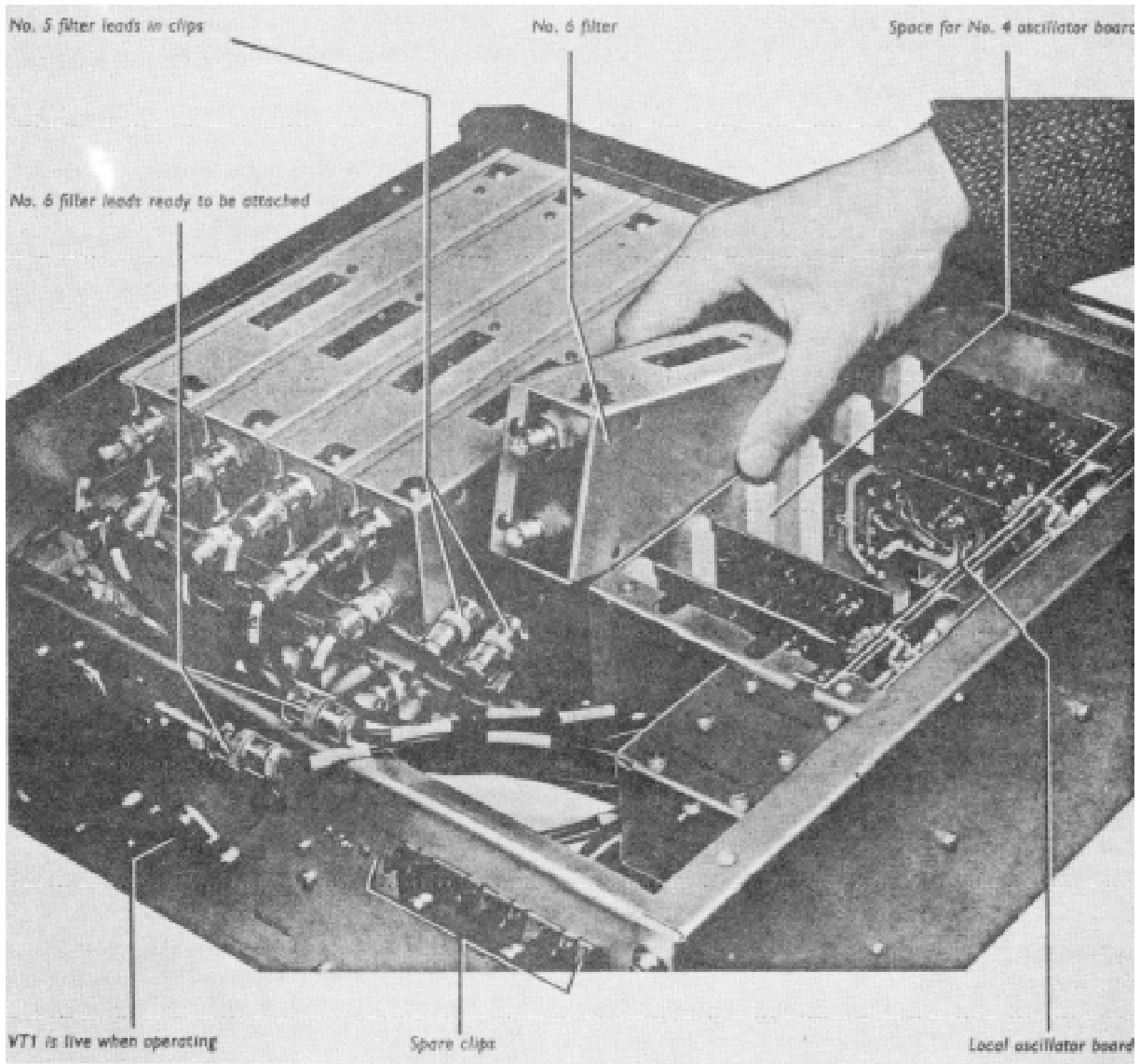

Fig. 4.3 Changing receiver filters

Inside the box the oscillator boards fit into sockets, and are steadied by slotted plastic blocks. The sockets are numbered from one to six to correspond to the setting of the FREQUENCY SELECTOR switch and the band-pass filter; a local oscillator board fitted in a certain socket will be selected with the appropriate filter when the switch is set to the corresponding number.

Press the board firmly into its socket and screw the lid down to hold it in place.

Note

Do not undo the screws in the front panels of the filters or blank panels in order to remove the panels.

Back-to back testing

A simple test of the apparatus is the 'back-to-back' test, where the output of the generator is fed straight into the receiver, eliminating all external effects. Carry out this procedure after fitting a new channel:

- (1) Set up the noise generator output to a level not greater than the C. C. I. R. recommendation for zero relative level as shown in Table 2.1. Feed this directly into the noise receiver.
- (2) Adjust the receiver gain to give a standard meter deflection when switched to the desired channel.
- (3) Switch the appropriate band-stop filter into the circuit and regain standard meter indication by rotating the noise power controls in the receiver. The new setting of these knobs should be at least 75 dB greater than the original, or 70 dB for frequencies below 50 kc/s.

4.7 ADJUSTMENT OF PRESETS

Test gear of a very high standard is required for these adjustments. Do not make any adjustment to the preset controls unless you are quite certain that it is necessary.

Apparatus required:

- (a) Multi-range d.c. voltmeter, 20 k Ω /V; e.g., Avometer Model 8.
- (b) Variable mains transformer; e.g., Variac.
- (c) Sweep generator, 15 Mc/s, with differential detector facility; e.g., Marconi Instruments Type TF 1099.
- (d) Oscilloscope with 15 Mc/s bandwidth.
- (e) R. F. step attenuator 0 to 60 dB in 1 dB steps; e.g., Marconi Instruments Type TF 1073A.
- (f) Standardized tunable level meter, 75 Ω impedance.
- (g) Standardized power meter, 75 Ω , for use up to 15 Mc/s. Up to at least 100 mW range, with an accuracy of $\pm 1/4$ dB.
- (h) Signal generator, 10 kc/s to 15 Mc/s; e.g., Marconi Instruments Type TF 144H.
- (j) Counter 10 kc/s to 12.5 Mc/s. (Marconi Instruments TF 1417 may be used up to at least 10 Mc/s. Above this frequency the Converter Type TF 1434 may be required.)
- (k) Valve voltmeter, d.c. to 15 Mc/s; e.g., Marconi Instruments Type TF 1041C.
- (l) Audio oscillator to produce 700 c/s, e.g. Marconi Instruments Type TF 2001.

Noise generator

Layout

When the top cover is removed all the active units are accessible. In screening boxes are : on the left the noise source, and next to it the low level amplifier; behind the attenuator cams the high level amplifier is mounted transversely, with the noise output transistor mounted in a heat sink between it and the right hand side panel. The meter circuit board stands unscreened behind the meter. Each cover is easily removed when its two fixing screws have been taken out.

The power supply lies inside the back panel, its printed board standing at one side adjacent to the input transformer. The series regulator transistor is mounted on a black heat sink, and has a live case.

Power unit

Preset controls: RV100, RV101, RV102

Apparatus required: a and b.

The following adjustments must be made with the normal working load on the power supply.

With the voltmeter across the 54 V supply, adjust RV101 to give exactly 54 V, then adjust RV102 to give 25 V on the 25 V line.

RV100 controls the stability of the h.t. supply. Measure the potential of the 54 V line, while varying the mains supply voltage by means of the variac between 190 and 260 V (or 95 and 130 V), and set RV100 to give the smallest possible variation in the h. t. supply.

Low level amplifier

Preset controls: RV300, RV301, C302, C306.

Apparatus required: c, e and d

Disconnect the coaxial leads connecting the low level amplifier to the noise source and the high pass filter. Connect the apparatus according to Fig. 4.4, feeding the output from the attenuator into SKT 300, and taking the output from SKT301 to the input probe of the sweep generator. A 75 f2 impedance match must be preserved at both the input and the output.

Switch on the supplies. Insert 52 dB in the external attenuator, and 10 dB in the sweep generator attenuator, giving an input of about 3 mV to the amplifier.

Set the sweep width to 13 Mc/s, and check the linearity with the cover on. Considerable non-linearity would suggest a faulty transistor or other component.

Remove the cover. Reduce the sweep width to minimum and adjust RV300 and RV301 to give zero differential deflection i. e., a gain of 52 dB at 100 kc/s. Increase the sweep width again, and adjust C302 and C306 to give the flattest possible response

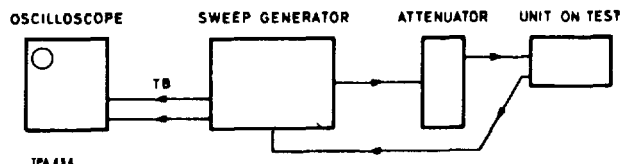

Fig. 4.4 Frequency response testing

High level amplifier

Preset controls: RV400, C405.

Apparatus required: c, e and d

Using the same procedure as for the low level amplifier, adjust the gain by means of RV400 to 32 dB at 100 kc/s, measured between PL400 and SKT400.

Frequency response may be adjusted by C405, and should be substantially flat with a slight rise at the high frequency and. This allows for h. f. losses in the interconnecting cables and attenuators.

Meter circuit

Preset controls : C501, RV500, RV501

Apparatus required: f, h and g

Turn the METER RANGE switch to the red range (high level). Feed the signal generator at approximately 50 mV, 100 kc/s, into the high level amplifier which should be terminated by switching in at least 10 dB on the output attenuator. Measure the level at the OUTPUT socket with the standardized level meter and note the indication on the front panel meter. Set up the same output level at 10 Mc/s, measured with the standard level meter. Adjust trimmer C501 to give the same indication as before on the front panel meter.

Disconnect the signal generator, reconnect the internal couplings and turn the output attenuator to 0. Switch in the lowland high-pass filters you normally use on the high range, and adjust RV500 over a range of powers until the internal meter agrees most closely with the standardized power meter connected to the output socket. Repeat on the low range with the appropriate bandwidth filters, adjusting RV501.

Noise source

Preset controls: RV200, RV201, C206.

Apparatus required: d and f

RV200 sets the current through the noise diode, which is of the order of 700 a, but which varies from one diode to the next. Unless you have the relevant information for the particular diode in your instrument and are quite certain that the instrument is faulty, you should not make any adjustment to this control.

As a rough guide to the correct working conditions of the diode it may be helpful to note that with no filters in and the output set to 17 dBm, the noise output viewed on an oscilloscope should appear balanced equally above and below the zero line. RV201 sets the available output level.

Set the tunable level meter to 100 kc/s, and drive it from the output of the low level amplifier. Adjust the potentiometer so that the level meter indicates 0.8 mV per kc/s into 75 S2 when the NOISE LEVEL control is turned fully clockwise.

Should it be necessary to change the setting of this control, the frequency response will be adversely affected. C206 is selected to give a flat response from 10 kc/s to 13 Mc/s when the NOISE LEVEL control is set to 8 to 10 dB below maximum output.

Noise receiver

Layout

The wide band amplifier, mixer and 1.f: amplifier are situated in similar cases above the chassis, in that

order from left to right when the front panel is towards you. Each cover is easily removed when the two fixing screws have been taken out. The meter and output rectifiers are in the 1. f. amplifier case, nearest to the meter.

The power unit is at the back, and the series regulator transistor is fitted to the back panel. Avoid touching it with any metallic object, for it is live when the supply is switched on.

The only other case on top of the chassis contains the 1. f. band-pass filter. The oscillator boards are housed underneath, in the frequency selector box.

Power supply

Preset controls : RV100, RV101.

Apparatus required: a and b

The following adjustments must be made with the normal working load on the power supply.

With the voltmeter connected between the h. t. line and earth adjust RV101 to give exactly 25 V.

RV 100 controls the stability of the h. t. supply. Measure the potential of the 25 V line, while varying the mains supply voltage by means of the variac between 190 and 260 V (or 95 and 130 V), and set RV100 to give the smallest possible variation in the h.t. supply.

Wide band amplifier

Preset controls: RV200

Apparatus required: h and k or, c,e and d

The gain of the amplifier should be 33 dB at 100 kc/s between SKTZOO and SKT201. Following the replacement of components it may be necessary to reset the gain by adjusting RV200. The input (750 ()) and the output (75 (2)) should be correctly terminated when the gain is measured.

Alternatively the gain may be measured using the sweep generator method illustrated under low level amplifier; in this case the external attenuator is set to 38 dB and the wide band amplifier input level to about 1 mV.

Frequency response may be upset by component changes, but in general, if the amplifier gives the correct gain after changing a transistor, the response will be satisfactory.

Mixer

Preset control: RV300

RV300 adjusts the current through VT300 for optimum mixer efficiency indicated by maximum meter reading when noise is fed into the receiver input socket from the noise generator.

Local oscillator

Preset controls : L1, RV1

Apparatus required: j and k

L1 sets the oscillator frequency, and should be set up at the ambient temperature, e.g., 20°C, for a frequency accuracy within 0.1%. Connect the counter via a blocking capacitor to the junction of R306 and C307 in the mixer, in order not to pull the oscillator frequency.

RV1 adjusts the output voltage, measured at the output socket of the oscillator box (do not disconnect the lead to the mixer, but make the connection inside the box).

The correct output voltage depends on the frequency of the oscillator as follows :-

Above 4 Mc/s: 1.1 V

Between 50 kc/s and 4 Mc/s : 0.6 V

Below 50 kc/s : 0.45 V

L.F. amplifier

Apparatus required: d, k and 1

With the OUTPUT LEVEL control set to maximum, the voltage gain of the amplifier should be between 87 and 95 dB at 700 c/s. To measure the gain feed a 700 c/s signal at a level of 20 μ V into PL400 and measure the output at the RECORD jack. It may be necessary (e.g., following replacement of a transistor) to select a new value for R412 to obtain this gain.

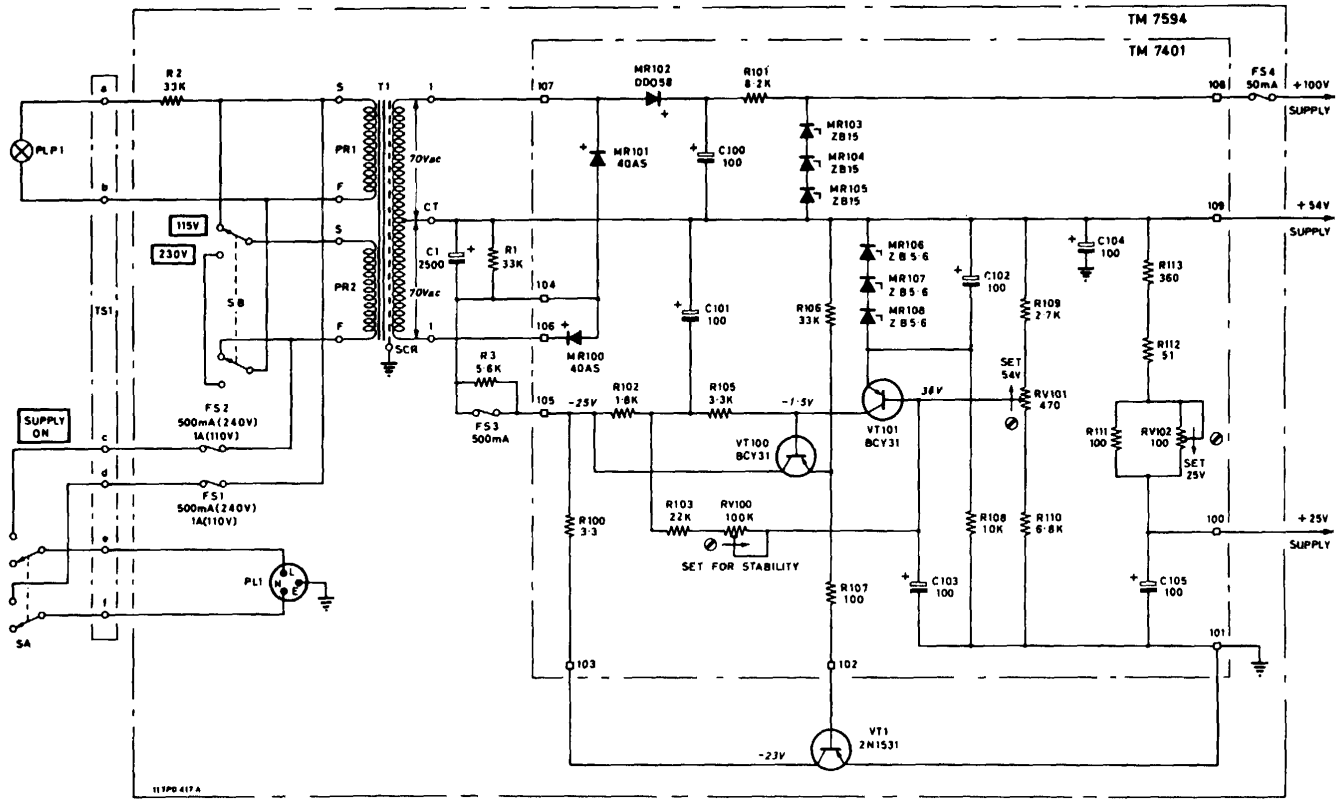

Fig. 4.5. Generator power supply circuit









1. COMPONENT VALUES

Resistors : No suffix = ohms. k = kilohms. M = megohms.
 Capacitors : No suffix = microfarads. p = picofarads.
 * value selected during test; nominal value shown.

2. VOLTAGES

These are d.c. and relative to chassis unless otherwise indicated. Measured with 20 k Ω /V meter.

3. SYMBOLS

-  arrow indicates clockwise rotation of knob.
-  etc., external front or rear panel marking.
-  tag on printed board.
-  other tag.
-  feed-through tag.
-  screwdriver adjustable preset.
-  signal path.
-  feedback path.

4. SWITCHES

Rotary switches are drawn schematically. Numbers or letters indicate control knob setting.

1F = 1st section (front panel), front
 1B = 1st section, back
 2F = 2nd section, front
 etc.

Figure. 4.5.1. Circuit notes.

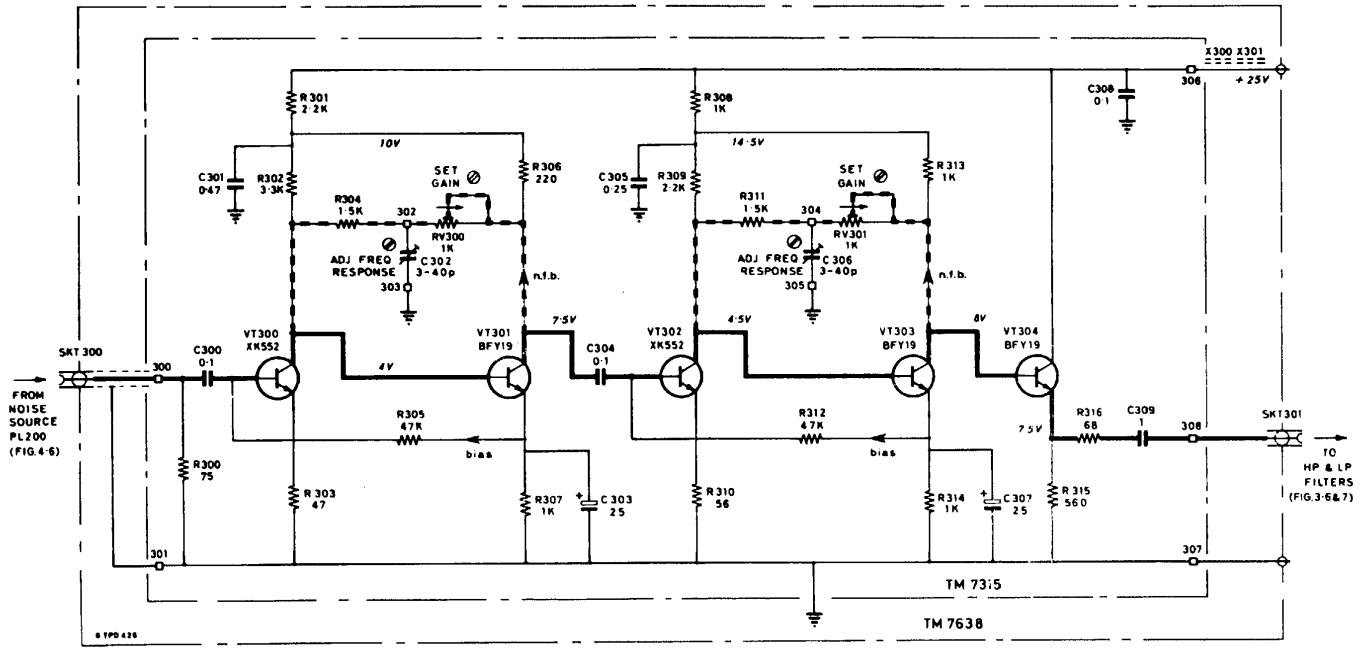

Fig. 4.7. Generator low level amplifier circuit

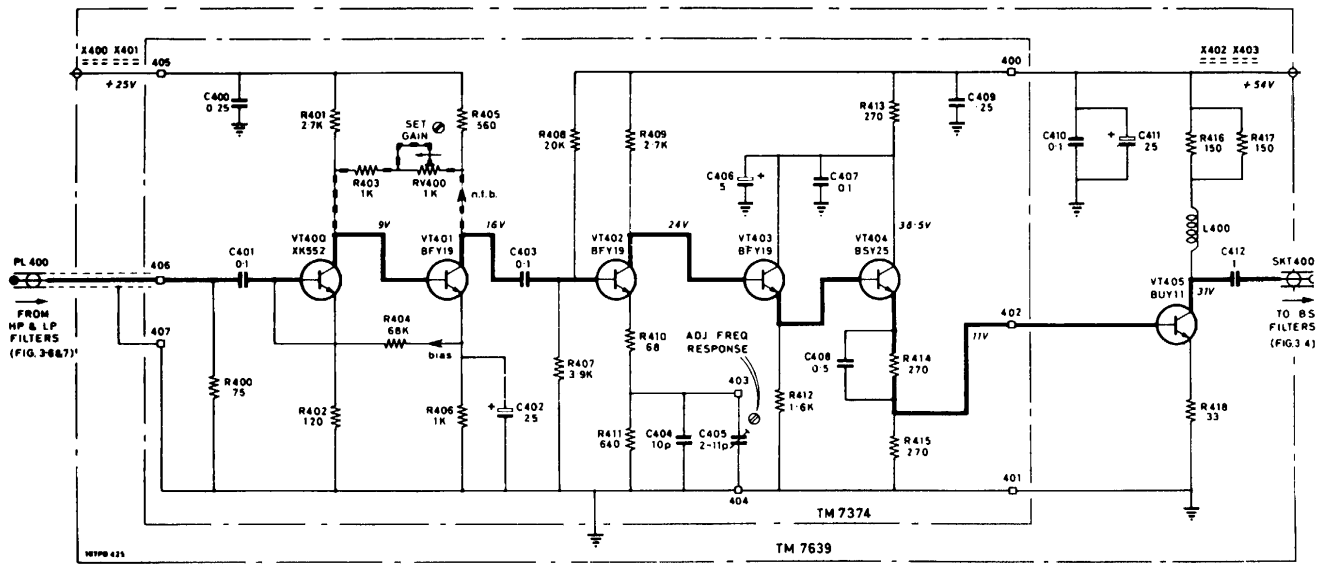

Fig. 4.8. Generator high level amplifier circuit

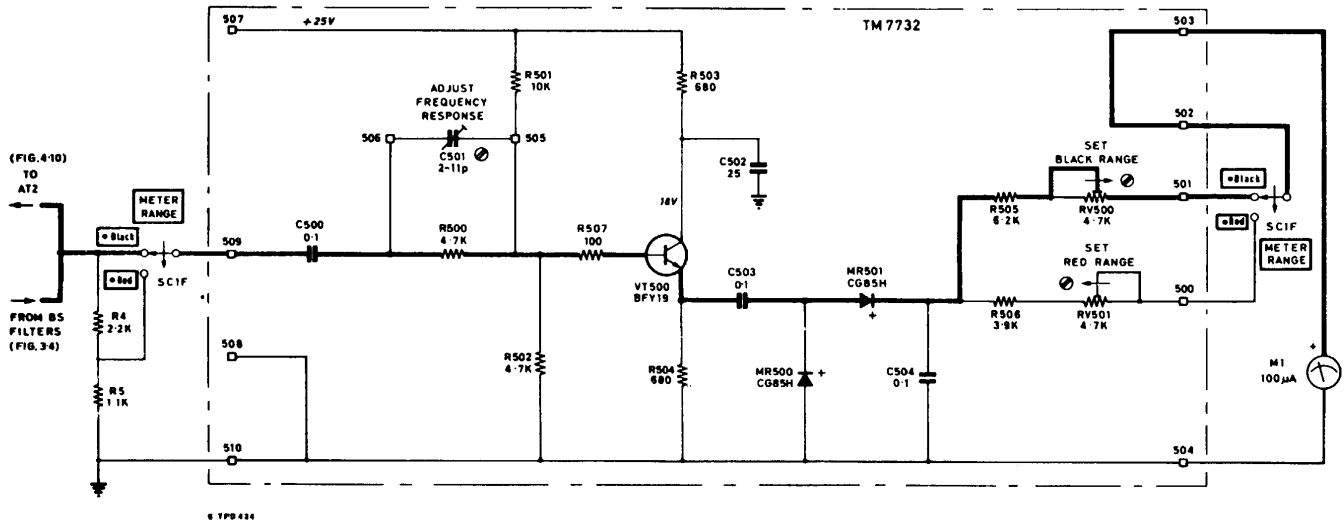

Fig. 4.9. Generator meter circuit

SET	ATTEN	PADS IN CIRCUIT (X)		
		10dB	20dB	30dB
0	0			
10	10	X		
20	20		X	
30	30	X	X	
40	40	X		X

3 TPC 428

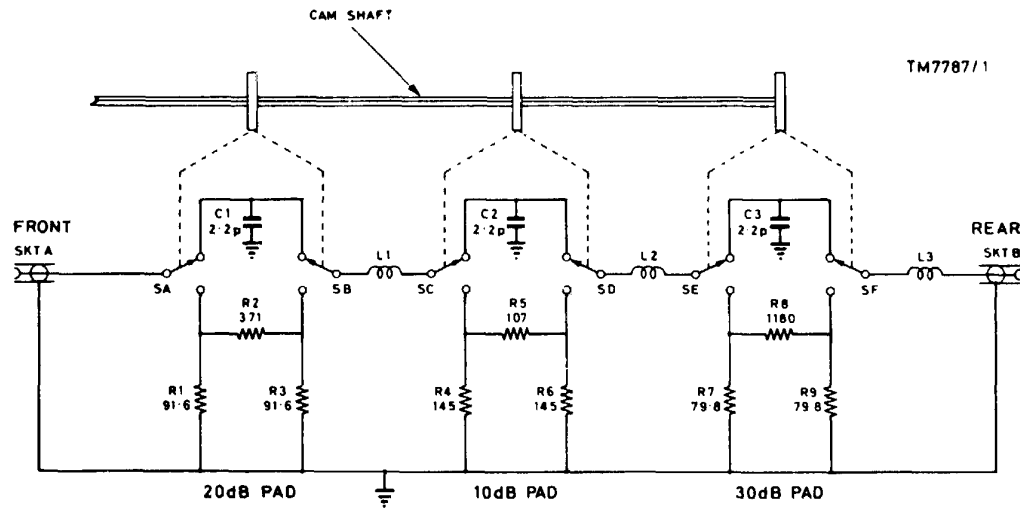

Fig. 4.10. Generator 40 dB step attenuator circuit

SET	ATTEN	PADS IN CIRCUIT (X)			
		1dB	2dB	3dB	6dB
0	0				
1	1	X			
2	2		X		
3	3	X	X		
4	4	X		X	
5	5		X	X	
6	6	X	X	X	
7	7	X			X
8	8		X		X
9	9	X	X		X
10	10	X		X	X
11	11		X	X	X

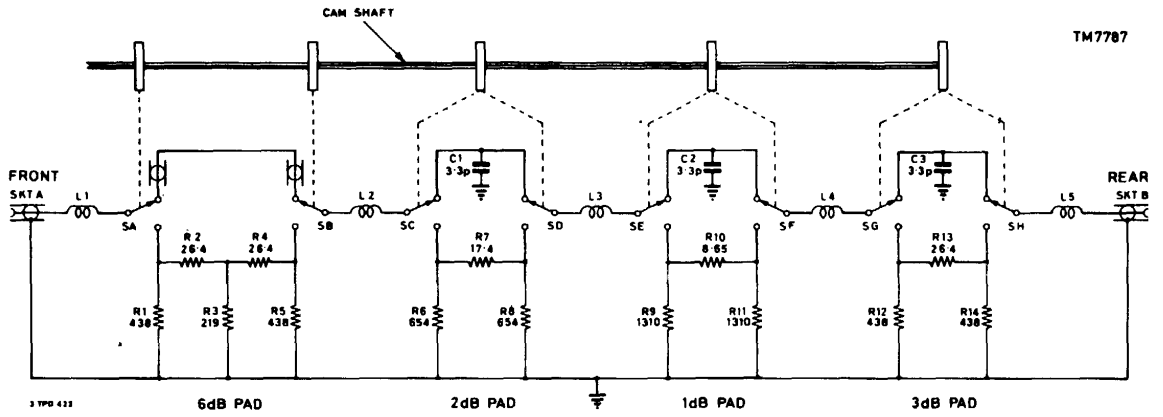

Fig. 4.11. Generator 11 dB step attenuator circuit

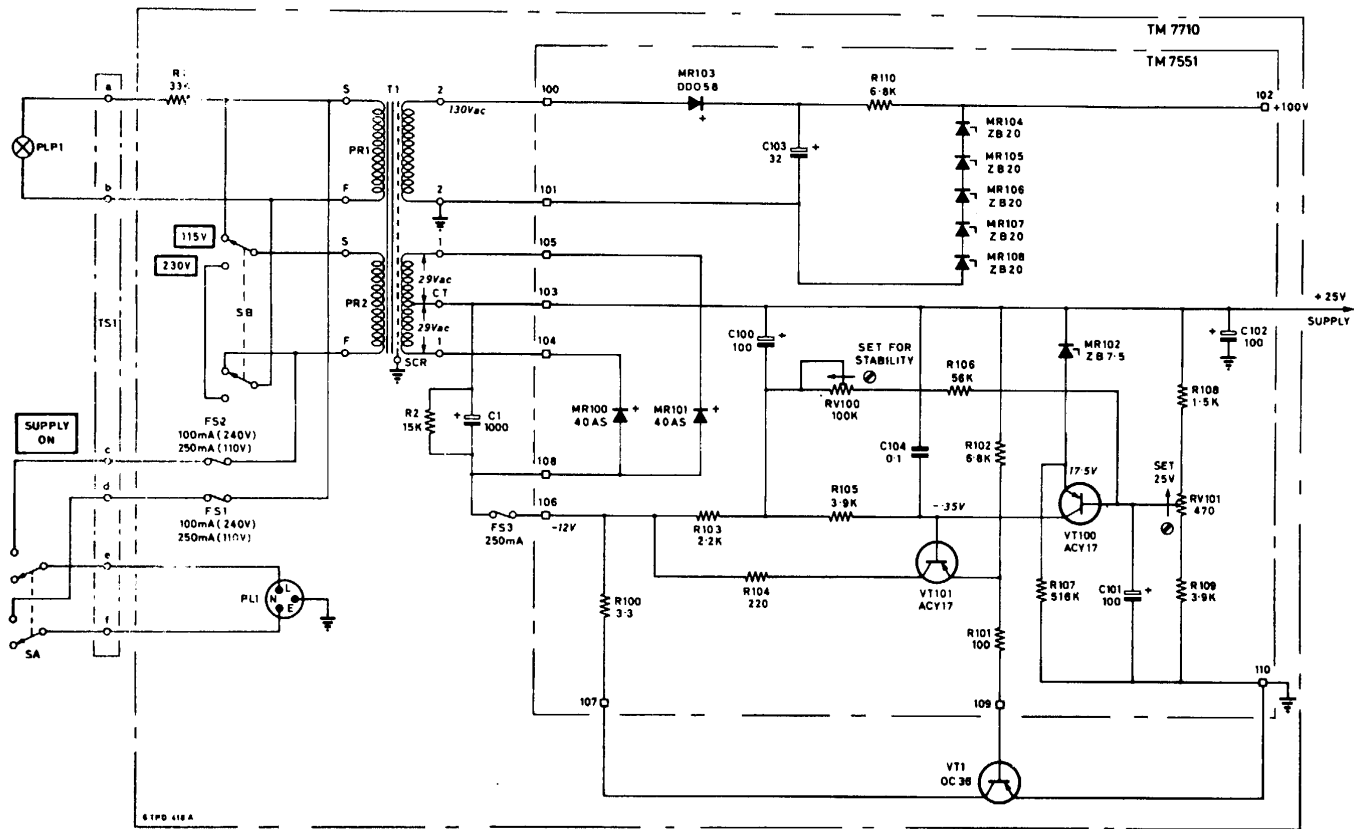

Fig. 4.13. Receiver power supply circuit

SET	ATTEN	PADS IN CIRCUITS (X)			
		10dB	20dB	30dB	60dB
20RED	100	X	X	X	
10RED	90	X	X	X	
0	80	X	X	X	
10	70	X			X
20	60	X	X	X	
30	50		X	X	
40	40	X	X	X	
50	30	X	X		
60	20		X		
70	10	X			
80	0				

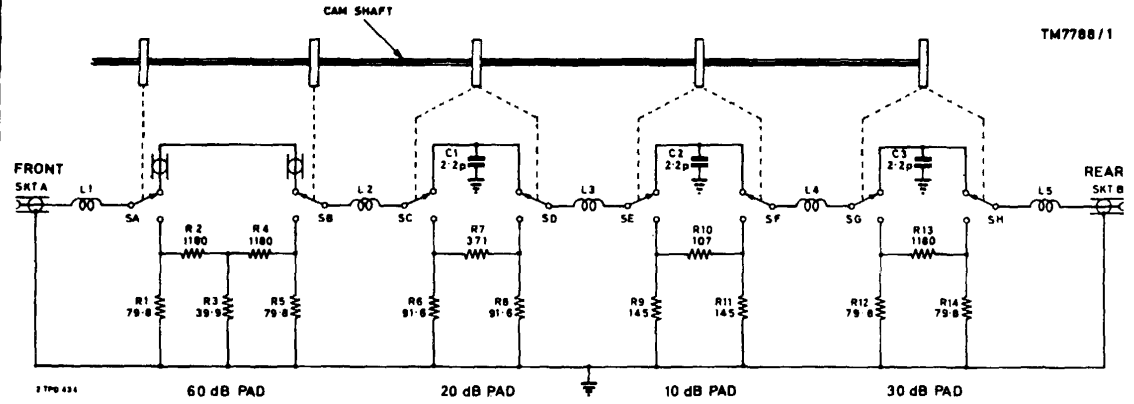

Fig. 4.14. Receiver 100 dB step attenuator

SET	ATTEN	PADS IN CIRCUIT (X)			
		1dB	2dB	3dB	6dB
0	11	X	X	X	
1	10	X	X	X	
2	9	X	X	X	
3	8	X	X	X	
4	7	X	X	X	
5	6	X	X	X	
6	5	X	X	X	
7	4	X	X	X	
8	3	X	X	X	
9	2	X	X	X	
10	1	X	X	X	
11	0				

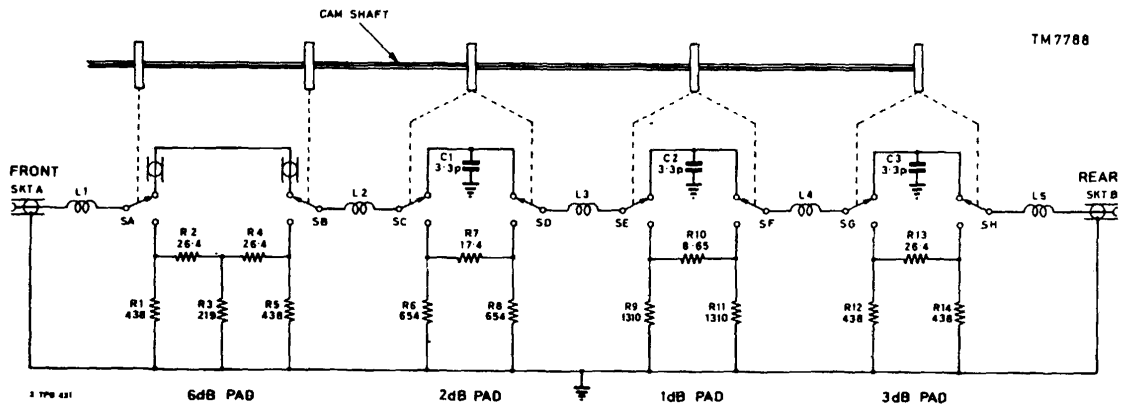

Fig. 4.15 Receiver 11 dB step attenuator

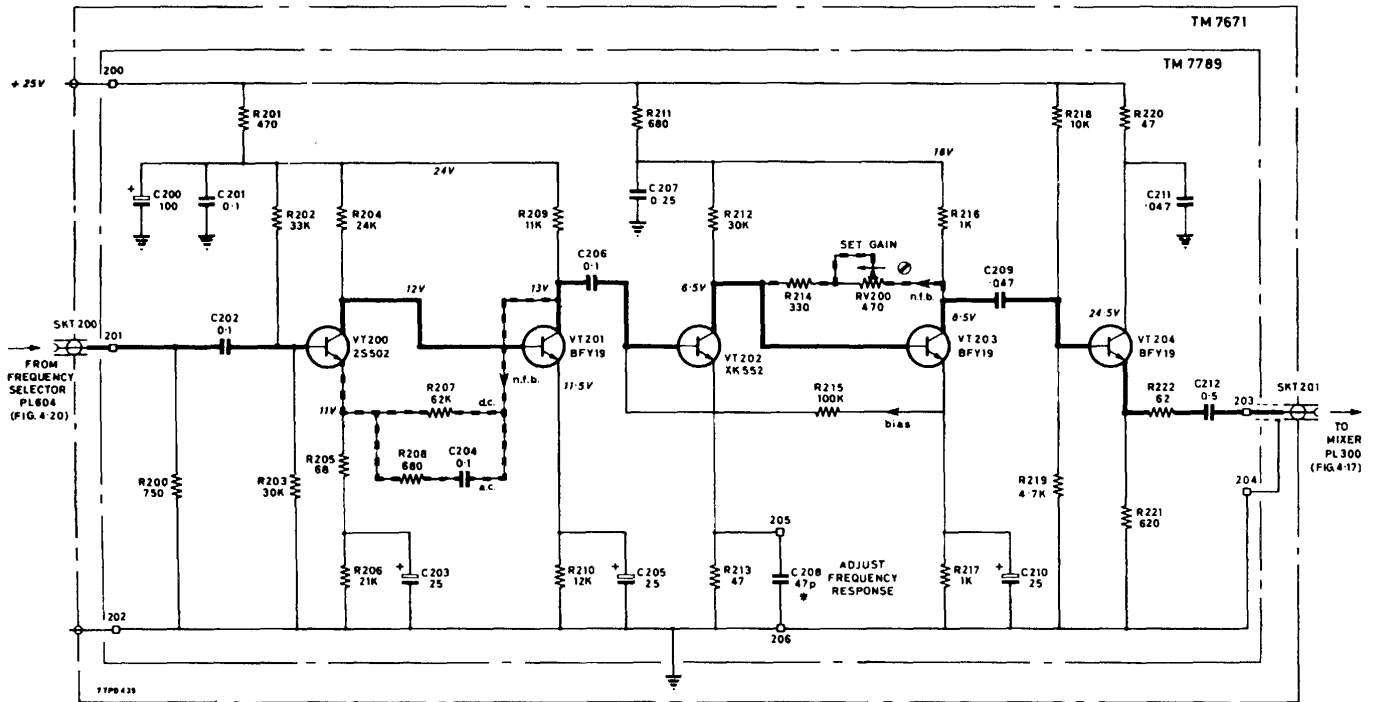

Fig. 4.16. Receiver wide band amplifier circuit

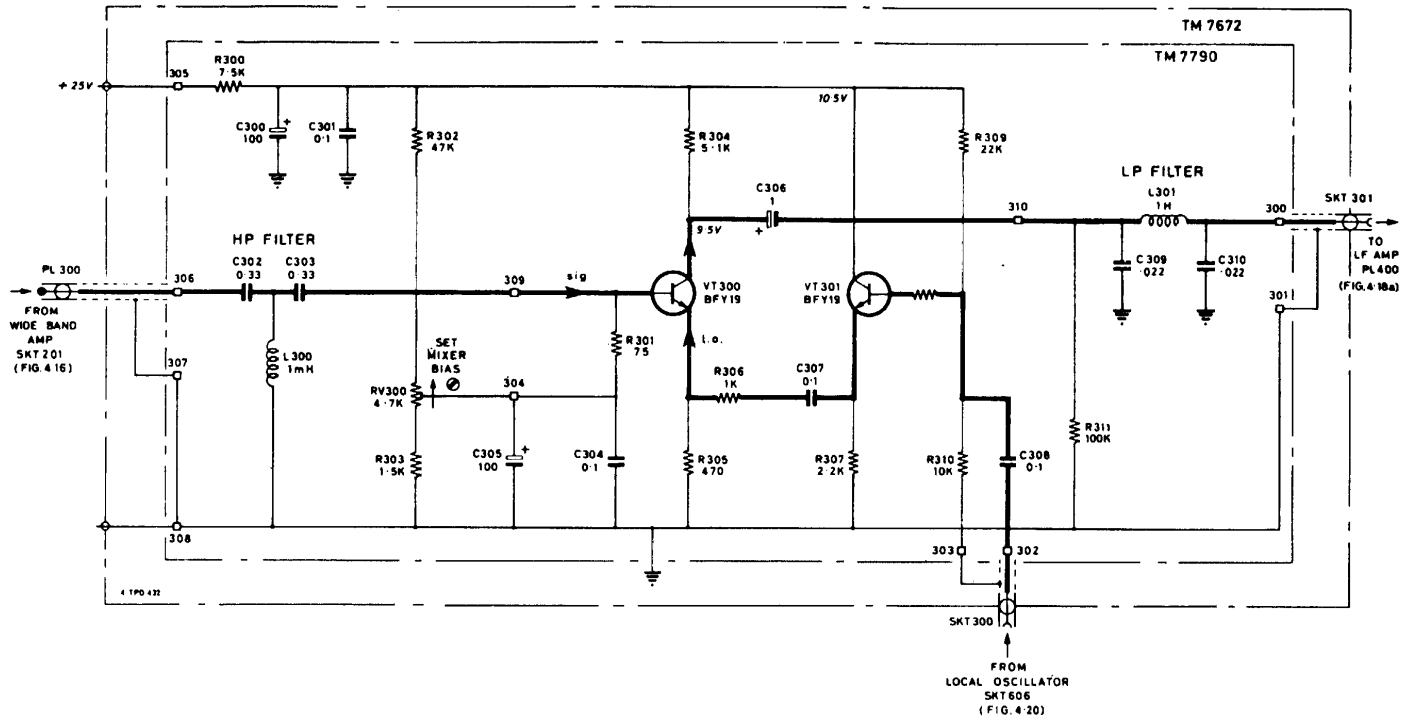

Fig. 4.17. Receiver mixer unit

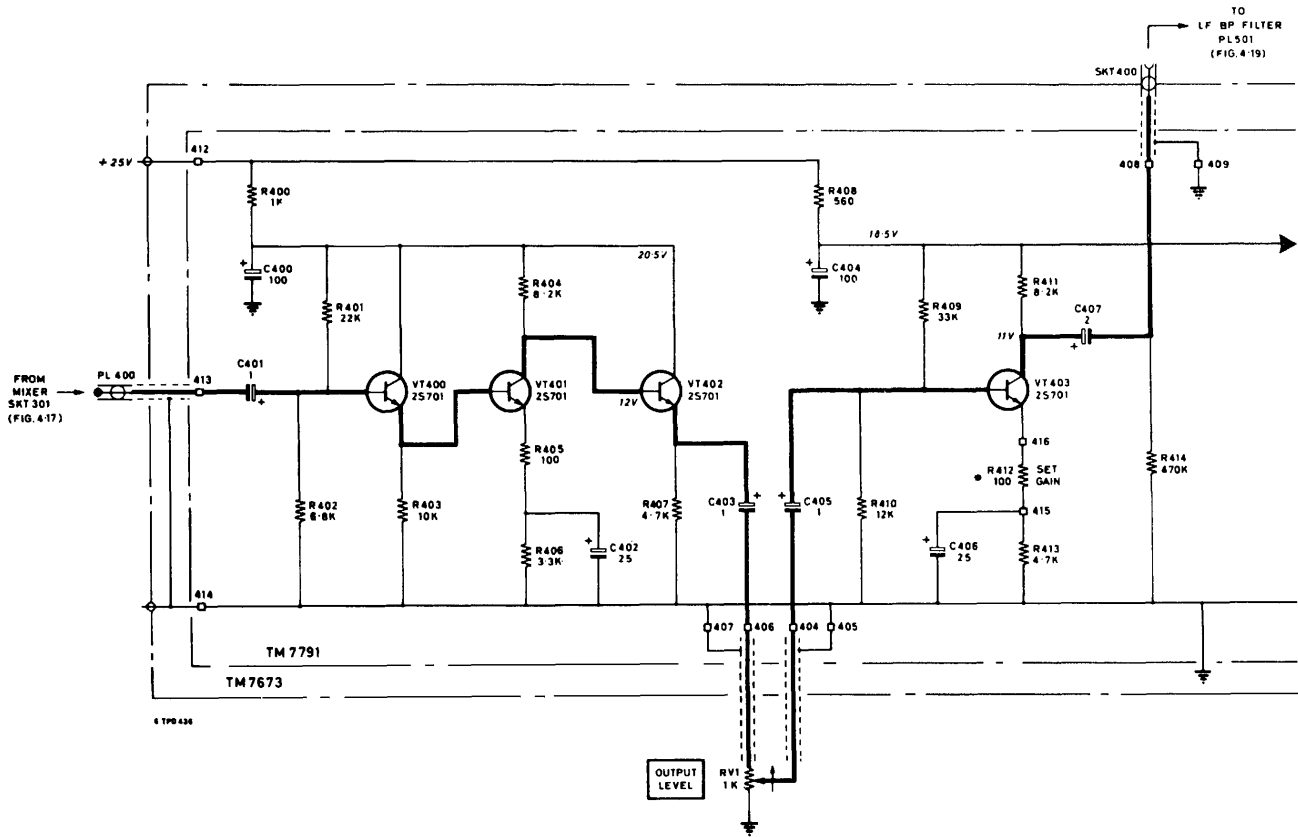

Fig. 4.18a Receiver I. f. amplifier circuit

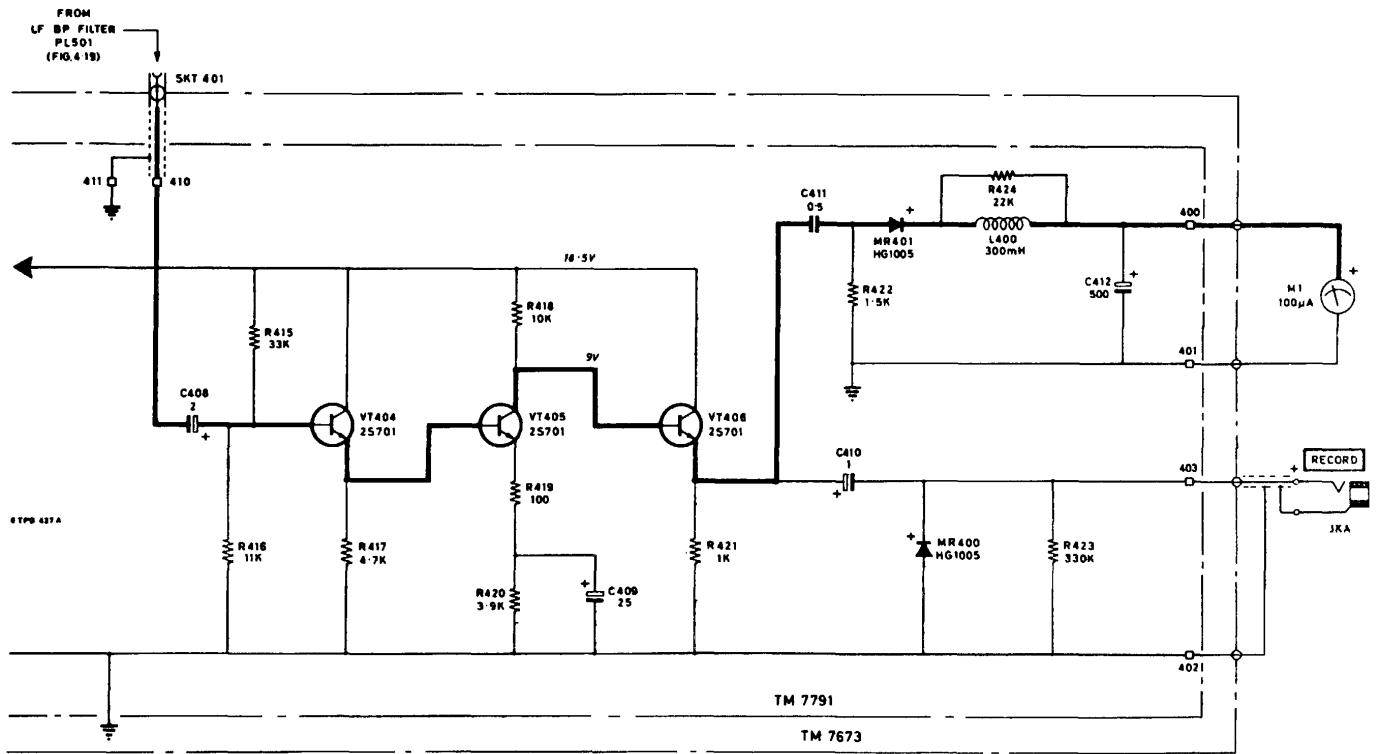

Fig. 4.18b Receiver I.f. amplifier circuit

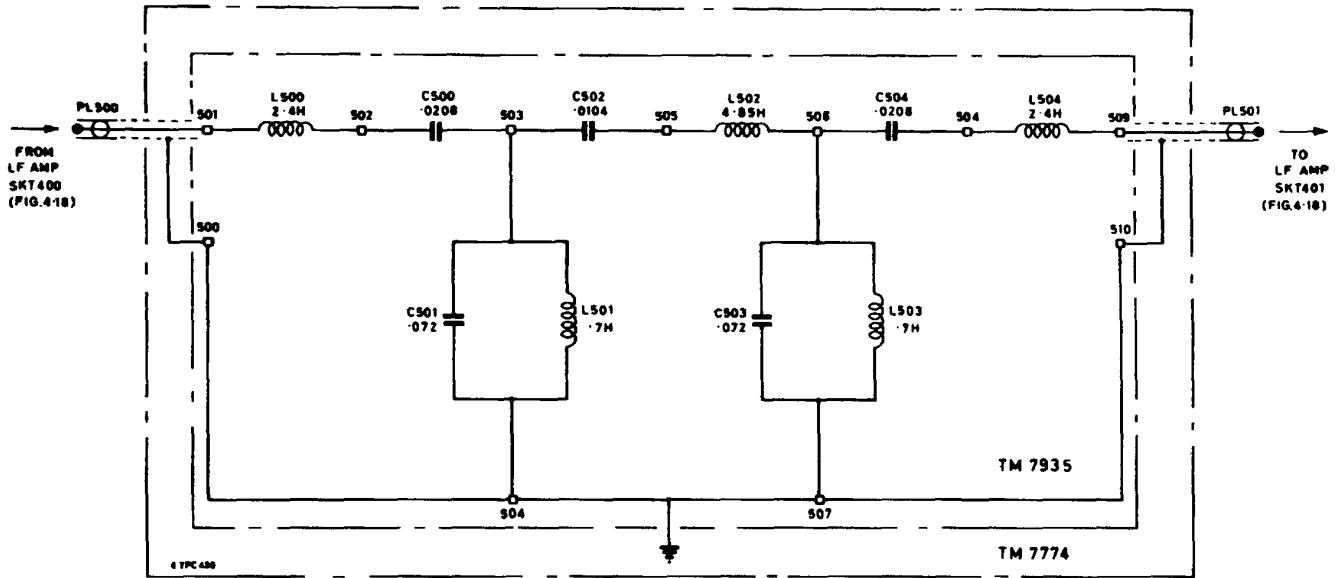

Fig. 4.19 Receiver I. f. band-pass filter unit

CONVERSION CHARTS

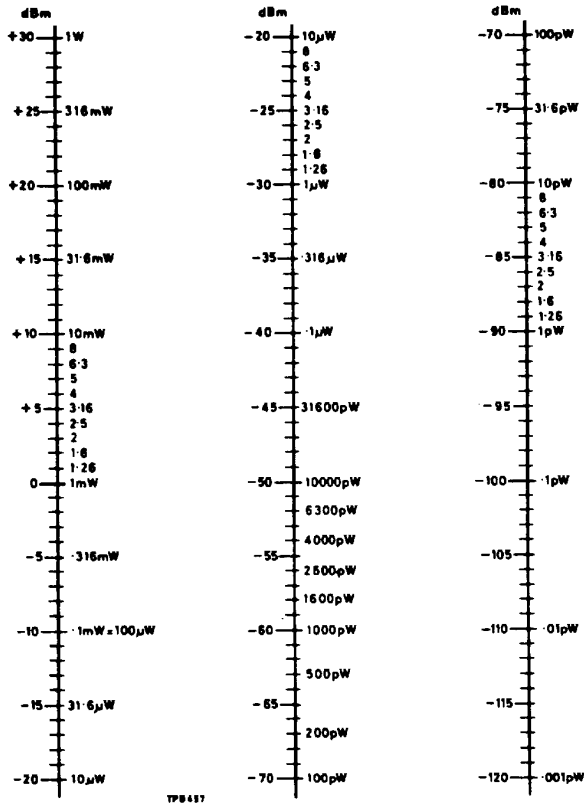

Fig. 4.21 Conversion chart dBr/watt

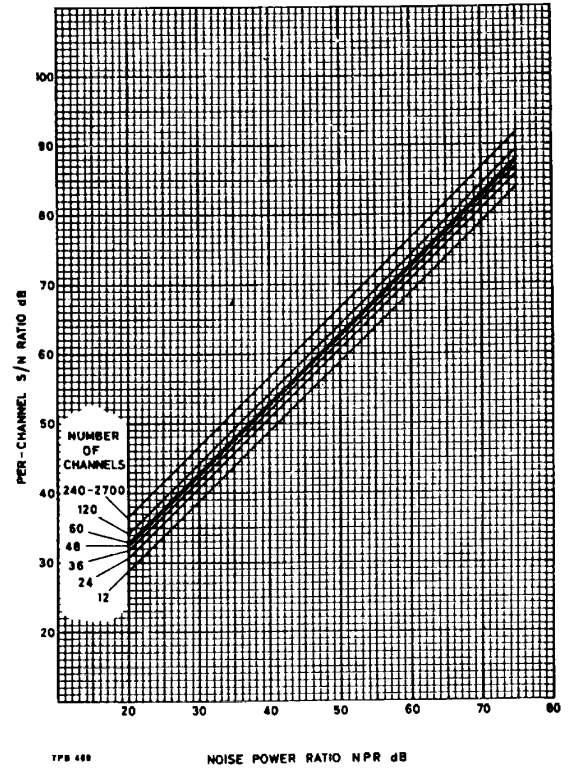

Fig. 4.22 Signal to noise ratio/noise power ratio

Typical Filters Available

High Pass Filters		Low Pass Filters		Band Stop & Band Pass Filters & Oscillators			
Frequency in kc	Type No	Frequency In kc	Type No	Frequency in kc	Type No.		Oscillator
					Band Stop Filter	Band Pass Filter	
12	TM 7728	60	TM 7720/8	14	TM 7729	TM 7730	TM 7793
60	TM 7728/1	108	TM 7720	34	TM 7729/12	TM 7730/12	TM 7793/2
316	TM 7728/2	300	TM 7720/1	40	TM 7729/1	TM 7730/1	TM 7793/1
		552	TM 7720/2	56	TM 7729/13	TM 7730/13	TM 7793/3
		1,300	TM 7720/13	70	TM 7729/2	TM 7730/2	TM 7794
		2,540	TM 7720/4	105	TM 7729/3	TM 7730/3	TM 7794/1
		4,028	TM 7720/5	185	TM 7729/4	TM 7730/4	TM 7794/2
		5,564	TM 7720/9	270	TM 7729/5	TM 7730/5	TM 7794/3
		8,204	TM 7720/6	290	TM 7729/14	TM 7730/14	TM 7794/5
		12,388	TM 7720/7	342	TM 7729/16	TM 7730/16	TM 7794/6
				534	TM 7729/6	TM 7730/6	TM 7794/4
				1,002	TM 7729/15	TM 7730/15	TM 7795/5
				1,248	TM 7729/7	TM 7730/7	TM 7795
				2,438	TM 7729/8	TM 7730/8	TM 7795/1
				3,886	TM 7729/9	TM 7730/9	TM 7795/2
				5,340	TM 7729/17	TM 7730/17	TM 7795/6
				8,002	TM 7729/10	TM 7730/10	TM 7795/3
				12,150	TM 7729/11	TM 7730/11	TM 7795/4

Typical Filter Frequencies for Various Capacities

No. of Channels	Band Limits		In-Band Slots			Out-of-Band Slots	
	High Pass	Low Pass	Lower	Center	Upper	Lower	Upper
12	12 kc	60 kc	27 kc	40 kc	50 kc	—	—
24	12 kc	108 kc	40 kc	70 kc	105 kc	—	—
36	12 kc	156 kc	40 kc	70 kc	105 kc	—	—
48	12 kc	204 kc	40 kc	105 kc	185 kc	—	—
60	12 kc	252 kc	40 kc	185 kc	245 kc	—	—
60	60 kc	300 kc	70 kc	185 kc	270 kc	50 kc	331 kc
120	60 kc	552 kc	70 kc	270 kc	534 kc	50 kc	607 kc
240	60 kc	1,052 kc	70 kc	534 kc	1,002 kc	50 kc	—
300	60 kc	1,300 kc	70 kc	534 kc	1,248 kc	50 kc	1,499 kc
600	60 kc	2,660 kc	70 kc	1,248 kc	2,438 kc	50 kc	3,200 kc
960	70 kc	4,028 kc	70 kc	2,438 kc	3,886 kc	50 kc	4,715 kc
960	316 kc	4,188 kc	534 kc	2,438 kc	3,886 kc	270 kc	4,715 kc
1,200	316 kc	5,564 kc	534 kc	3,886 kc	5,340 kc	—	—
1,800	316 kc	8,204 kc	534 kc	3,886 kc	8,002 kc	—	—
2,700	316 kc	12,388 kc	534 kc	3,886 kc	12,150 kc	—	—

5 CALIBRATION AND TROUBLESHOOTING PROCEDURES

5-1. GENERAL

The scope of this **section** covers the calibration of the Model 2090 Noise Loading Test Set to bring its specifications within the published limits, trouble-shooting procedures, and parts location illustrations. Operation and routing maintenance are covered in the **sections 1-4**.

5-2. EQUIPMENT REQUIRED - The test equipment required for calibration and trouble-shooting will be the same as listed in paragraph 4.7, with the exception that the standardized power meter, referenced as item (g), should be replaced by a true RMS Voltmeter with a 75-ohm termination, such as Hewlett-Packard Model 3400A.

5-3. PERFORMANCE CHECKING PROCEDURES - Noise Generator TF2091

a. NOISE GENERATOR POWER LEVEL The power output available from the noise generator will depend upon the bandwidth which is determined by the choice of high and low pass filters used. The levels shown in Table 2.1, should be attainable. Noise power is measured with the true RMS Voltmeter* terminated with a 75-ohm load and connected to the OUTPUT socket of the noise generator by the 75-ohm cable.

The equipment settings should be:

High and Low Pass Filter	-	IN
Band Stop Filters	-	OUT
Attenuators (both)	-	0dB
Power Switch	-	ON

Where these levels are unattainable, a fault condition exists -- see trouble-shooting section.

(a) Set NOISE LEVEL control to maximum and determine that available power is sufficient for bandwidth in use.

(b) Check that the meter indicator of noise power is within specification when compared with the external meter at various points on each scale. When recalibration is required, refer to page 23

b. ATTENUATOR ACCURACY Use the same set-up as used in a. above.

(a) Fine Attenuator 0-11dB. Adjust the NOISE LEVEL control to give a full scale reading on the voltmeter. Switch in the attenuator steps one by one, checking against voltmeter reading. Return FINE ATTENUATOR to 0dB,

*True RMS Voltmeter may be calibrated in dBm, watt 600 ohms load, in which case a correction must be made. Voltmeters calibrated wrt 600 ohms will read 9dBm low; e.g., 0dBm (75 ohms) will be shown as -9dBm on voltmeter calibrated wrt 600 ohms. (However, load must be 75 ohms, NOT 600 ohms.)

(b) Coarse Attenuator 0-40dB. Adjust the NOISE LEVEL control to give 0dB indication on the voltmeter. Switch in attenuator steps in turn and change voltmeter to 10dB lower range to correspond -voltmeter should continue to read on the 0dBm mark within the accuracy of the equipment.

A2.3.3 NOISE LEVEL FLATNESS Connect the selective voltmeter to the output of the noise generator via the 75-ohm cable with the voltmeter set to 75 ohms impedance 1 4Kc BW, and tune the voltmeter slowly over the pass band of the noise. The frequency response should be within specification. Adjustment procedures are shown on page 23 and also in the trouble-shooting section. (NOTE: It is not possible to measure the response of the band stop filters using the selective voltmeter with noise applied, due to the inherent intermodulation distortion in selective voltmeters.

5-4. PERFORMANCE CHECKING PROCEDURES Noise Receiver TF2092

a. NOISE RECEIVER SENSITIVITY Set the noise generator to the correct power level for the bandwidth in use and connect to the receiver. Set all attenuators and receiver to 0dB. Switch the receiver to each of the channels in turn. On each channel, a reading of at least 1/2 full scale on the meter should be obtainable within the range of the OUTPUT LEVEL control. Check that residual noise of the receiver is not excessive by disconnecting the noise generator and observing that the previous reading decreases by at least 20%. Where the required sensitivity is not achieved, refer to the trouble-shooting section.

b. ATTENUATOR ACCURACY Remove case from instrument and remove the OUTPUT BNC connector (PL611) from the Receiver attenuator. Connect selective voltmeter to the attenuator output socket. Connect the signal generator (tuned to 1Mc) to INPUT of noise receiver. Tune selective voltmeter for maximum reading, rotate each attenuator one position at a time, and cross-check with reading on selective voltmeter. Accuracy should be within specifications.

c. BACK TO BACK TEST This test is an overall test of noise generator, noise receiver, band stop, band pass filters, and oscillator modules. Connect as in paragraph a and test as specified on page 22, The basic noise power ratio of the equipment itself should be within specification, otherwise refer to trouble-shooting section.

5-5. TROUBLE-SHOOTING PROCEDURES

The following table lists troubles that may be encountered during calibration of the test set, possible causes or fault areas to be checked, and recommended remedial procedures to be followed. The table is divided into two parts, one for the Noise Generator TF2091 and the other for the Noise Receiver TF2092.

NOISE GENERATOR TF2091		
SYMPTOM	POSSIBLE FAULT AREAS	REMEDIES
NOISE OUTPUT INSUFFICIENT OR NONEXISTENT	Fuses blown	Replace fuses.
	Power supply	Check power supply voltages. See page 23.
	Internal interconnections in error	Check.
	Attenuator faulty	Check. Measure level at output of band stop filters. If output at this point, check attenuators as below.
	Band stop filter faulty	Measure level at output of high level amplifier. If output at this point, check switches in band stop filters. If necessary, adjust inconsistencies.

NOISE GENERATOR TF2091 (Cont)		
SYMPTOM	POSSIBLE FAULT AREAS	REMEDIES
NOISE OUTPUT INSUFFICIENT OR NONEXISTENT (Cont)	No output from high level amplifiers	Faulty output transistor on high level amplifier. Check as on page 23 . If o.k., check input level to high level amplifier.
	High and low pass filters defective	Check switches, otherwise replace.
	No output from low level amplifiers	Check low level amplifier and noise source together with interconnecting cables. See page 23.
NOISE OUTPUT BUT NO METER READING	Meter P.C board.	Check voltages on Meter P.C board, switch wiring, and meter itself.
NOISE LEVEL BANDWIDTH IN ERROR	High and low pass filters	Replace with alternates.
ATTENUATOR STEPS IN ERROR	Attenuators	Check for broken springs or loose mounting if steps open circuit. Otherwise check for broken resistors, shorts, etc.
NOISE LEVEL DISAPPEARS WHEN BAND STOP FILTER INSERTED	Filter switch	Check microswitch contacts, shorts. Otherwise replace.

NOISE RECEIVER TF2092		
NOTE: Normally, meter reading on receiver fluctuates to a greater extent than on the noise generator due to restricted bandwidth in receiver. This is not to be considered a fault condition		
SYMPTOM	POSSIBLE FAULT AREAS	REMEDIES
NO READING ON RECEIVER	B.S. filter in noise generator	Check that all B.S. filters switched out.
	Blown fuses	Check and, if necessary, replace.
	Power supply	Check all power supply voltages and, if necessary, check power supply using Manual.
	Faulty B.P. filter	Connect voltmeter with 750-ohm load to output of particular B.P. filter. Insertion loss should be not greater than 9dB. If necessary, replace filter.
	Faulty oscillator module	Check that oscillator is fitted correctly. Check oscillator frequency and level (page 25). Adjust or replace.
	Faulty modules	Check wide band amplifier, mixer, band pass filter, LF amplifier, and meter (page 24). Check interconnections between units.
ATTENUATOR FAULTY GIVING ERRATIC NPR READINGS	Attenuator	Check in same manner as noise generator.

5-6. PARTS LOCATION ILLUSTRATIONS

Figures 5-1 through 5-18 show location of component parts in both the noise generator and the noise receiver. The parts are identified by reference designations to facilitate identification and replacement of individual parts.

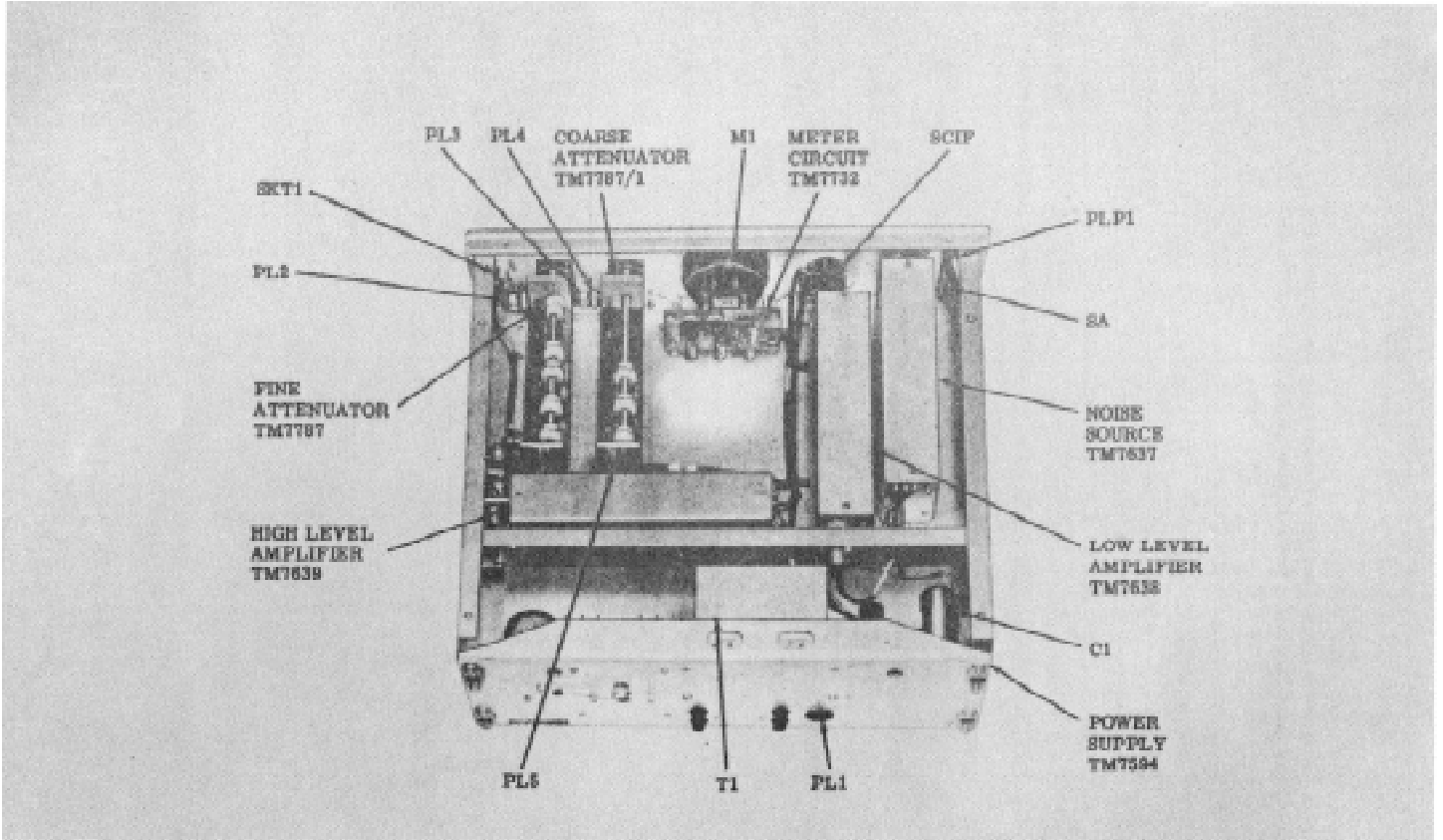

Fig. 5-1. NOISE GENERATOR TF2091, UPPER REAR VIEW.

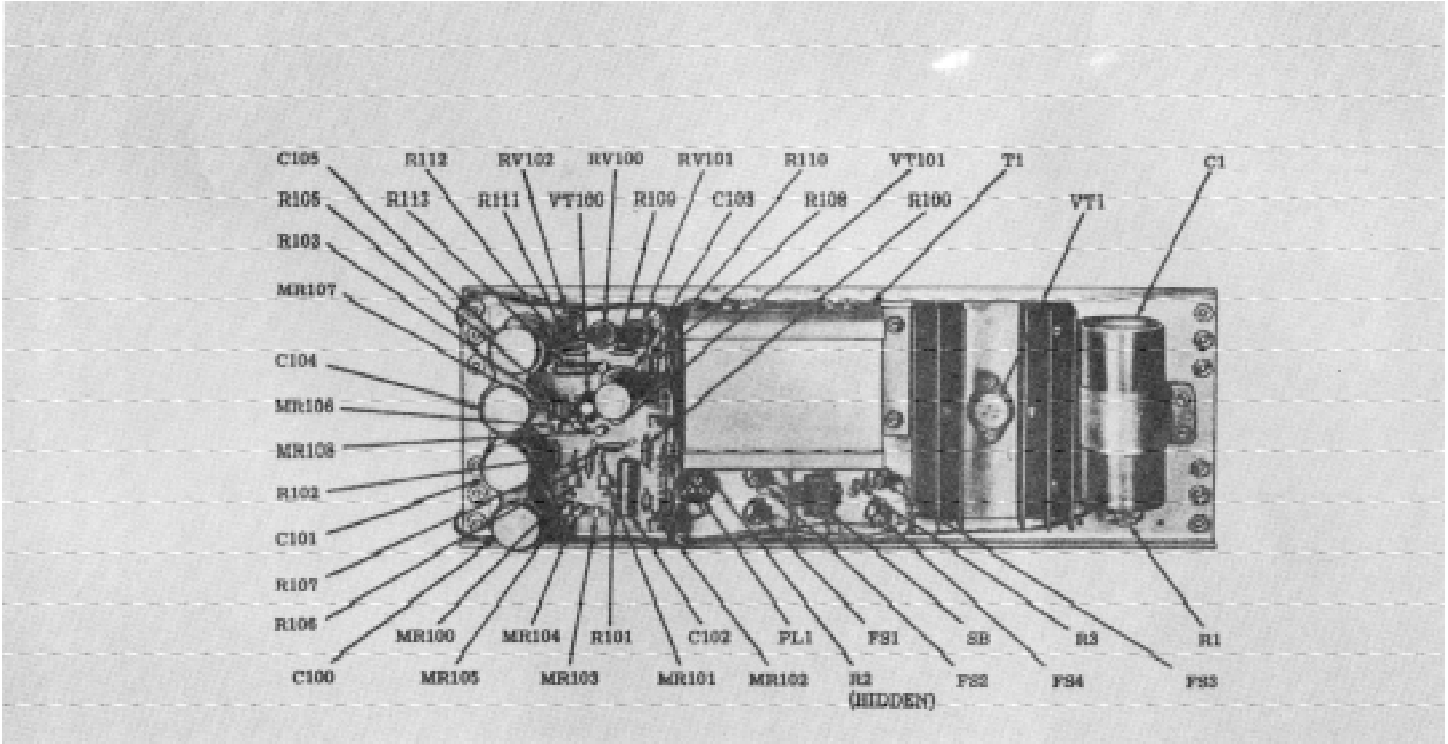

Fig. 5-2. NOISE GENERATOR, POWER SUPPLY TM7594.

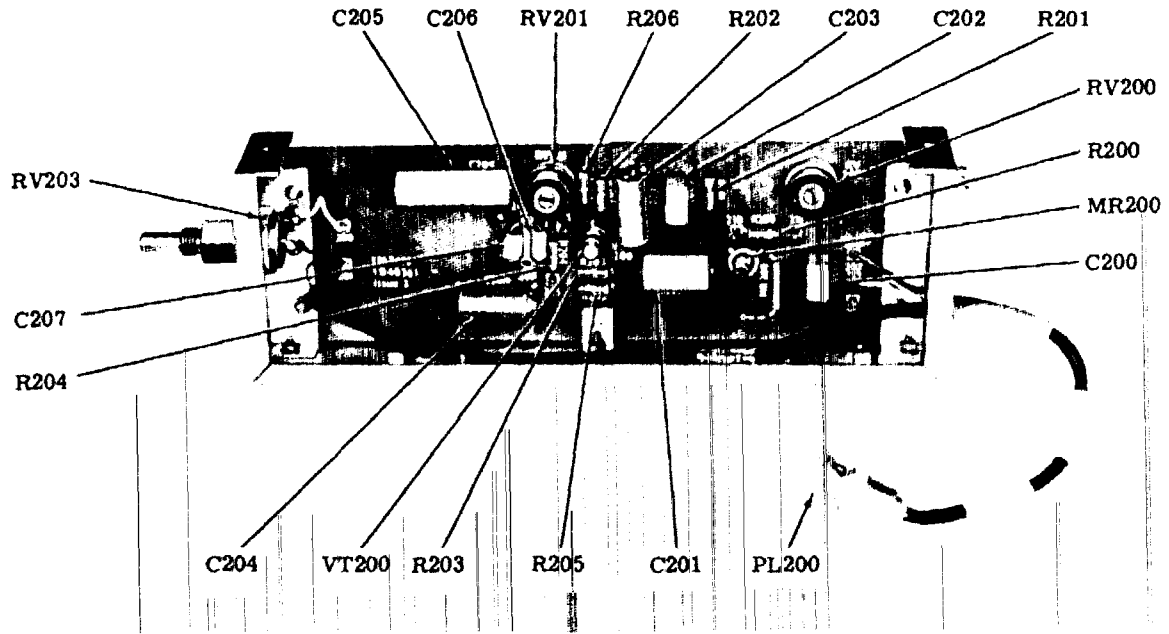

Fig. 5-3. NOISE GENERATOR, NOISE SOURCE TM7637

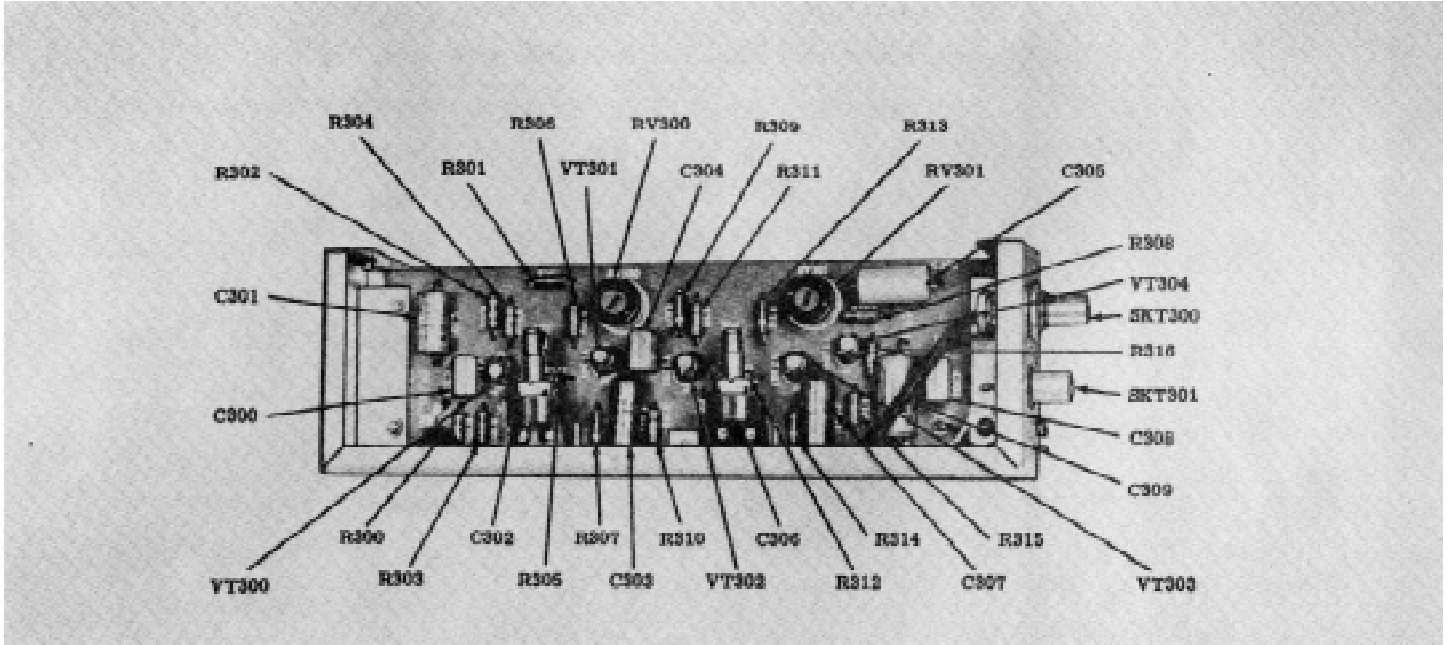

Fig. 5-4. NOISE GENERATOR, LOW LEVEL, AMPLIFIER TM7636

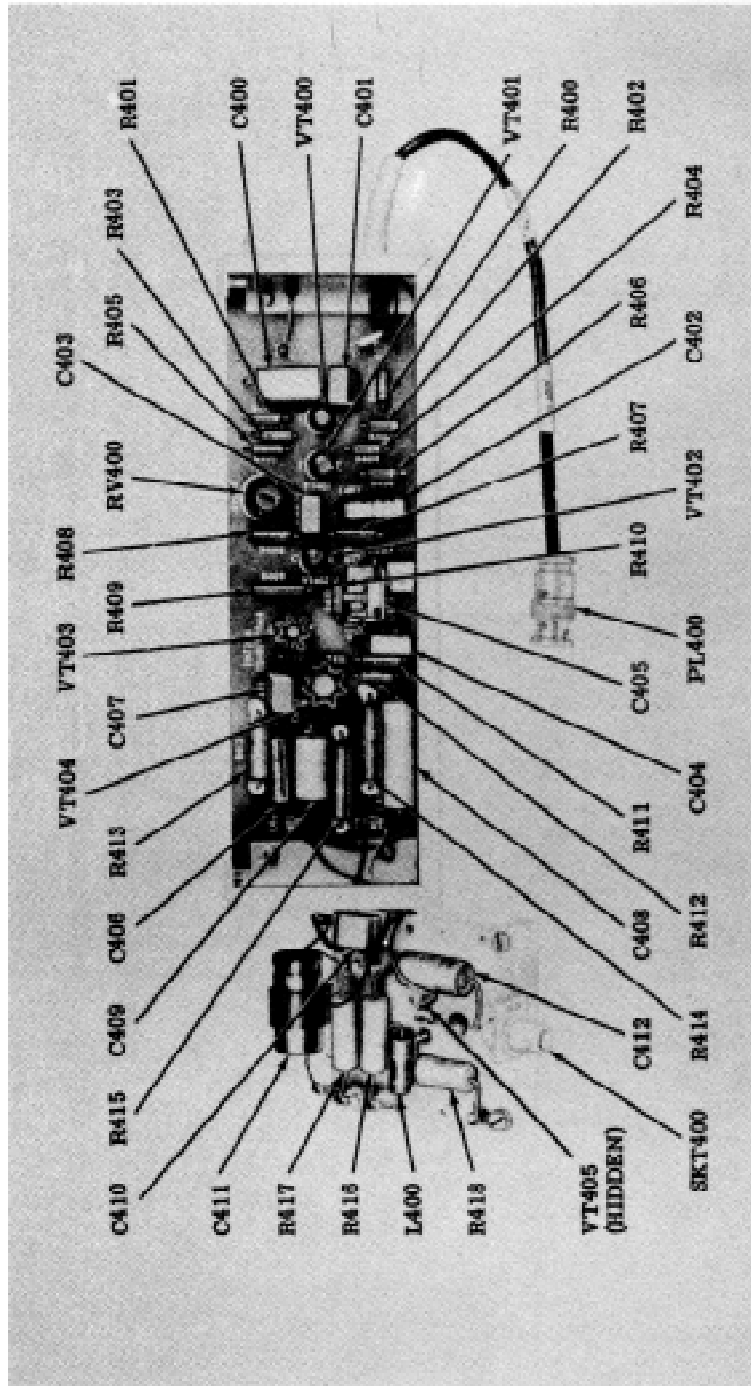

Fig. 5-5. NOISE GENERATOR, HIGH LEVEL AMPLIR TM7639

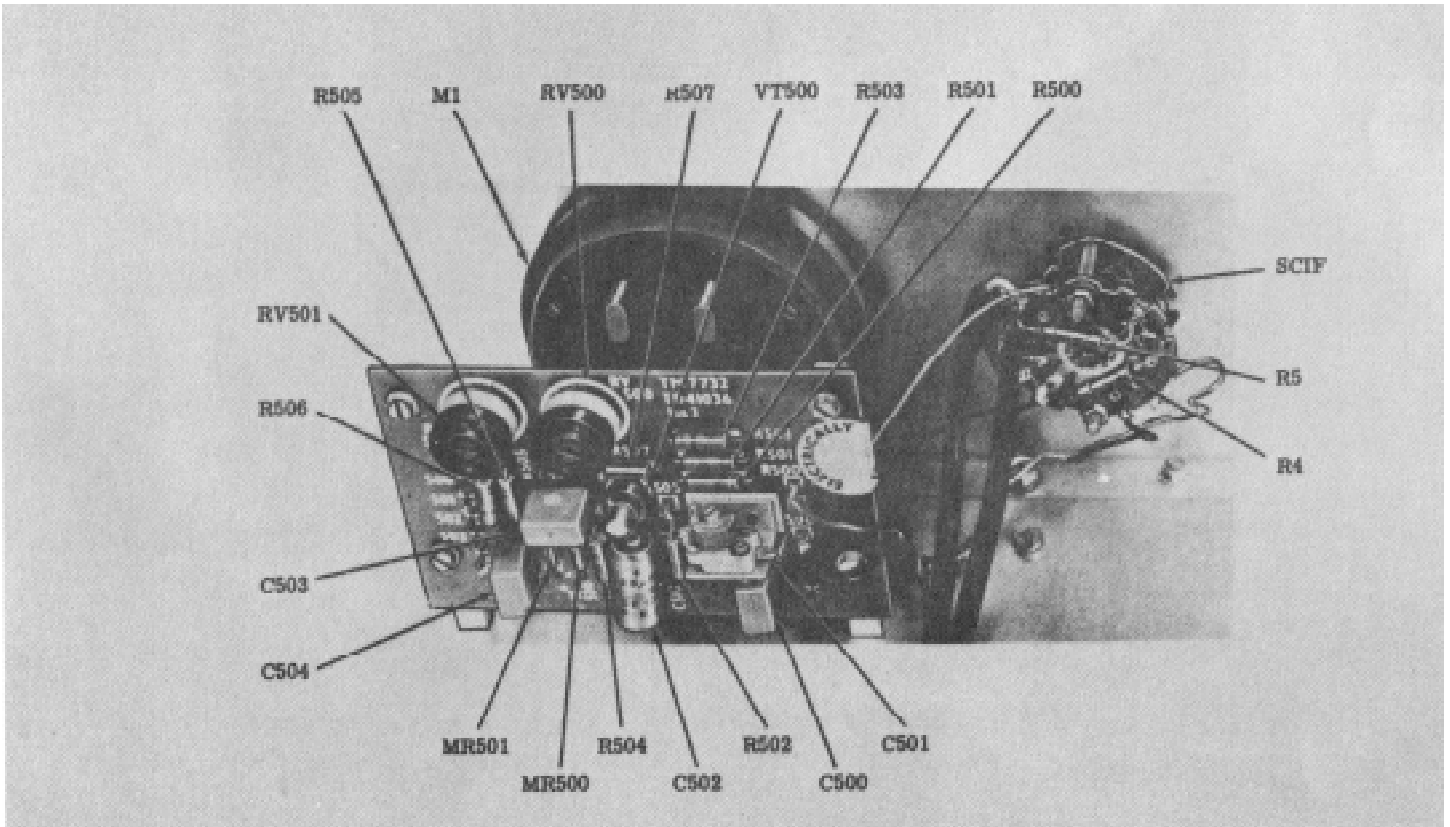

Fig. 5-6. NOISE GENERATOR, METER CIRCUIT TM7732

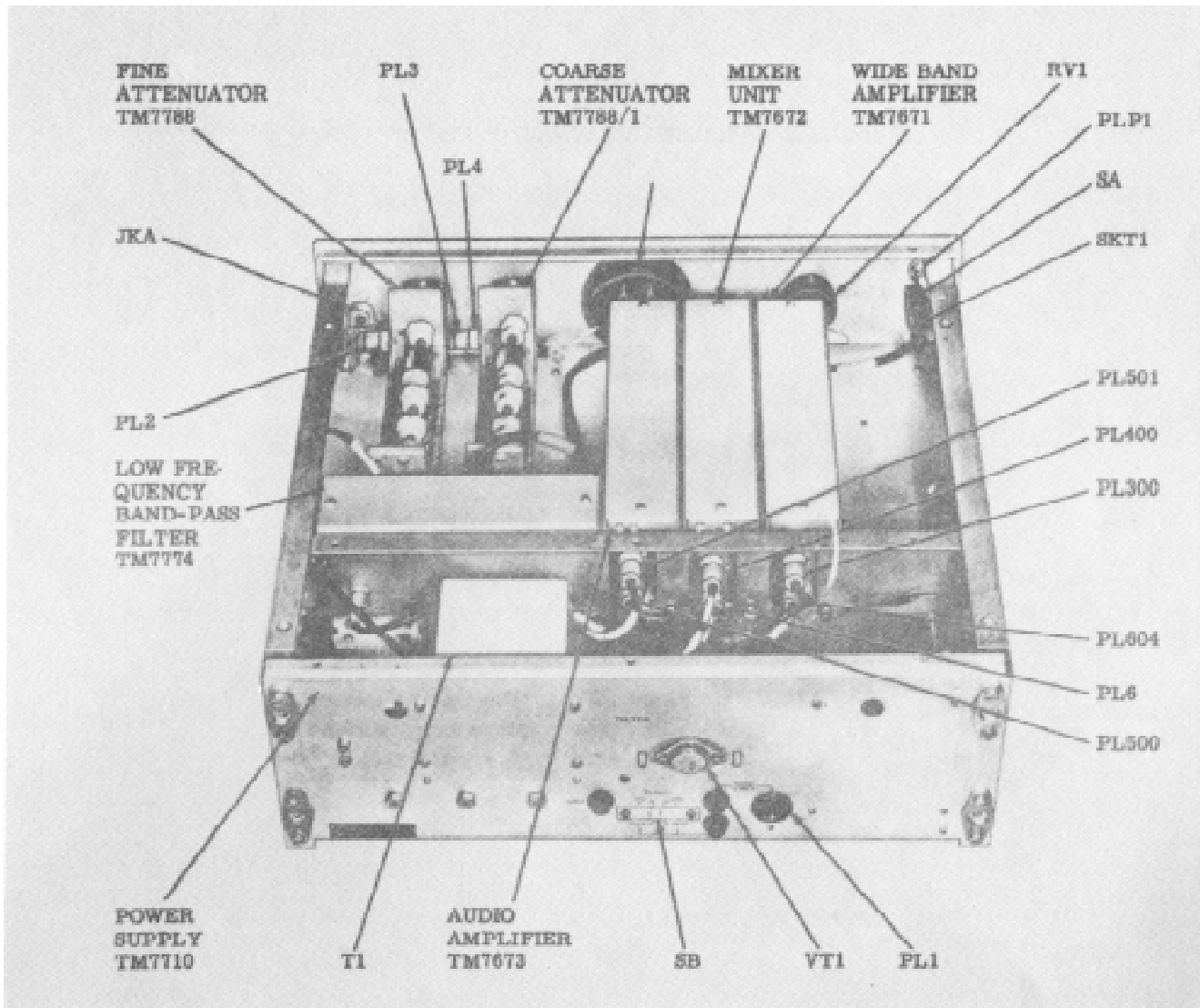

Fig. 5-7. NOISE RECEIVER TF2092, UPPER REAR VIEW

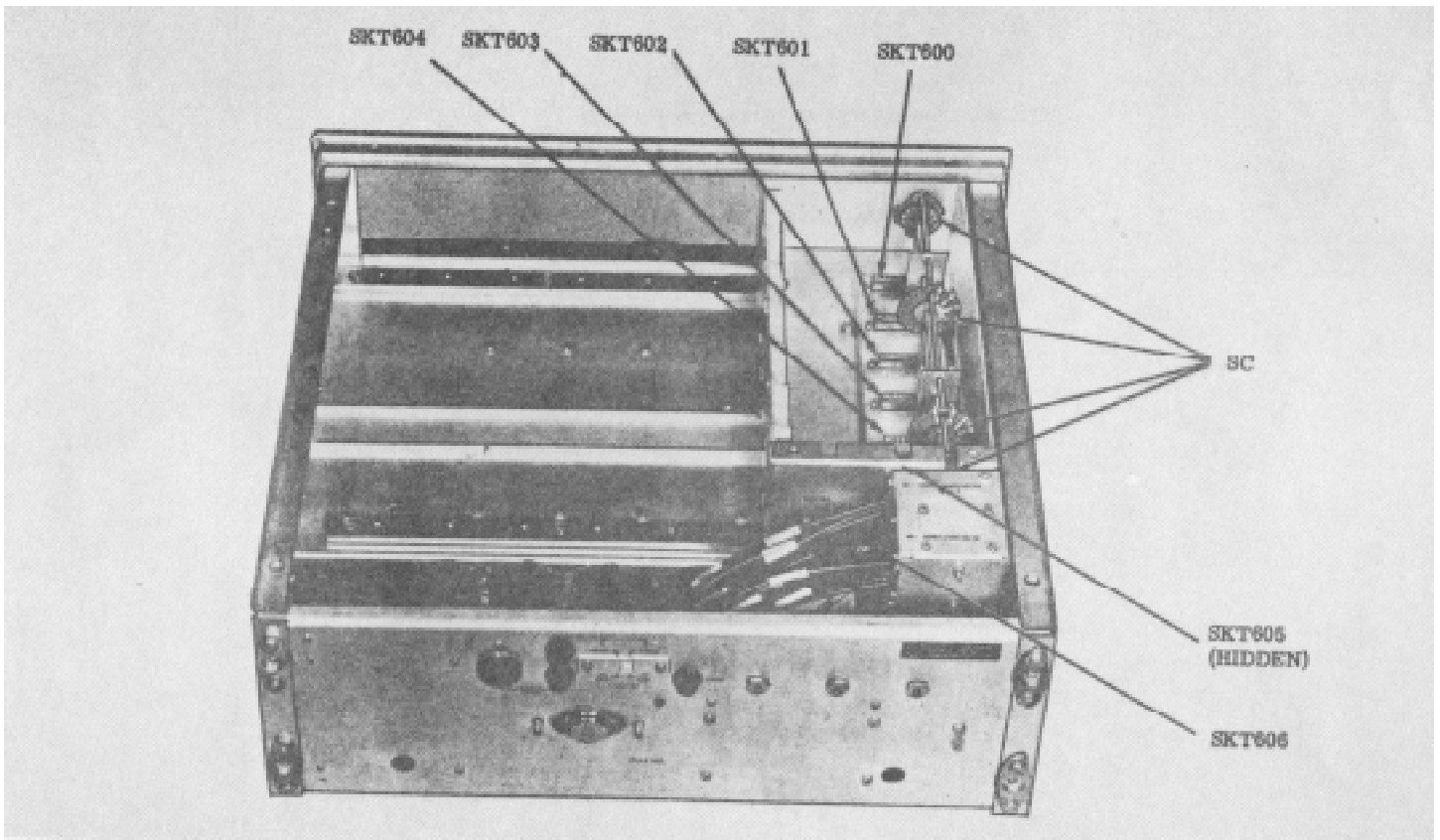

Fig. 5-8. NOISE RECEIVER TF2092, BOTTOM REAR VIEW, SHOWING OSCILLATOR UNIT TM7775

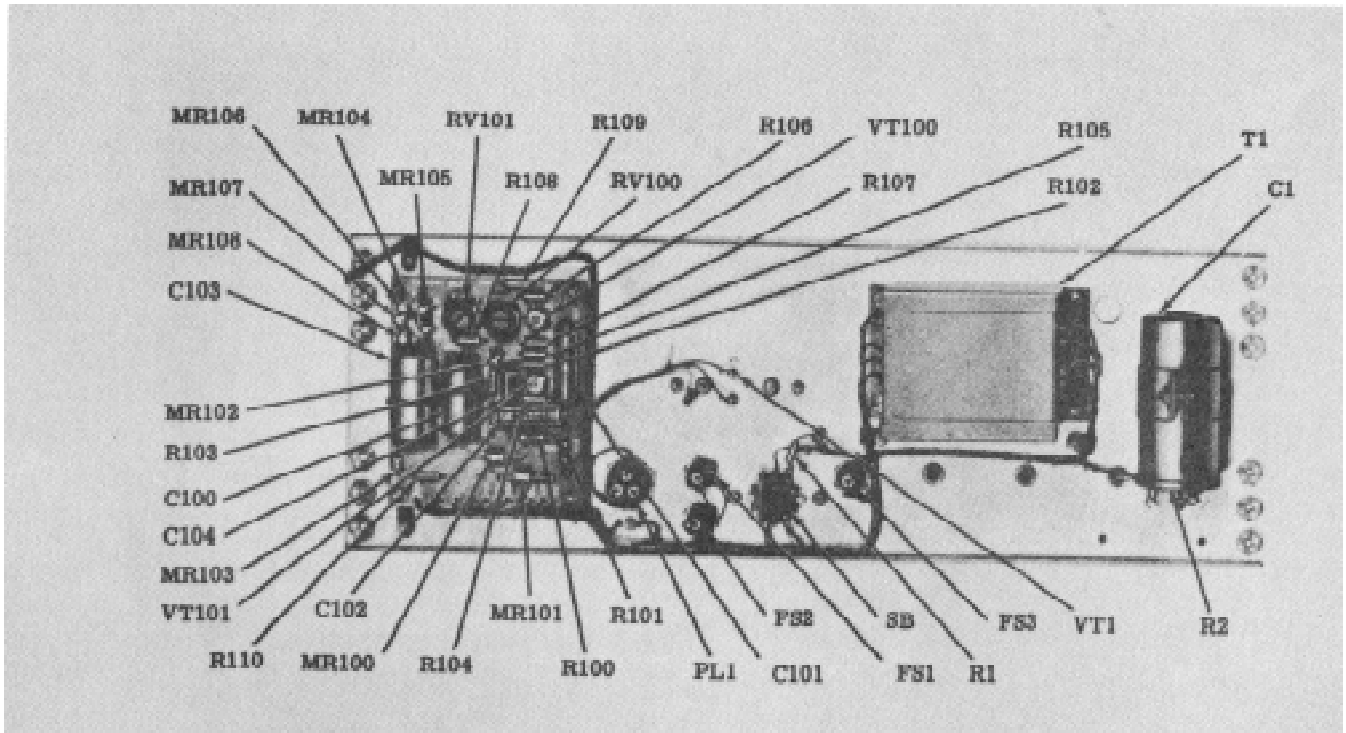

Fig. 5-9. NOISE RECEIVER, POWER SUPPLY TM7710

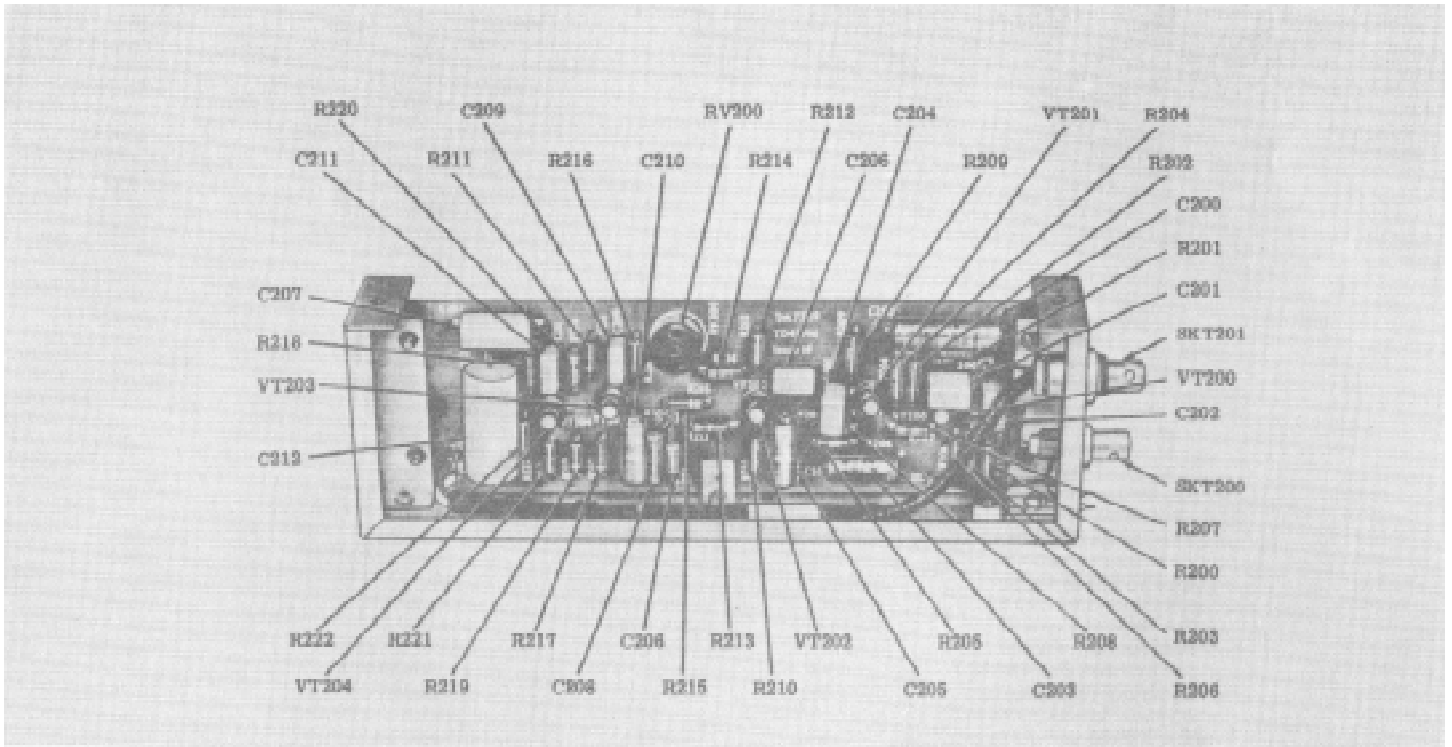

Fig. 5-10. NOISE RECEIVER, WIDE BAND AMPLIFIER TM7671

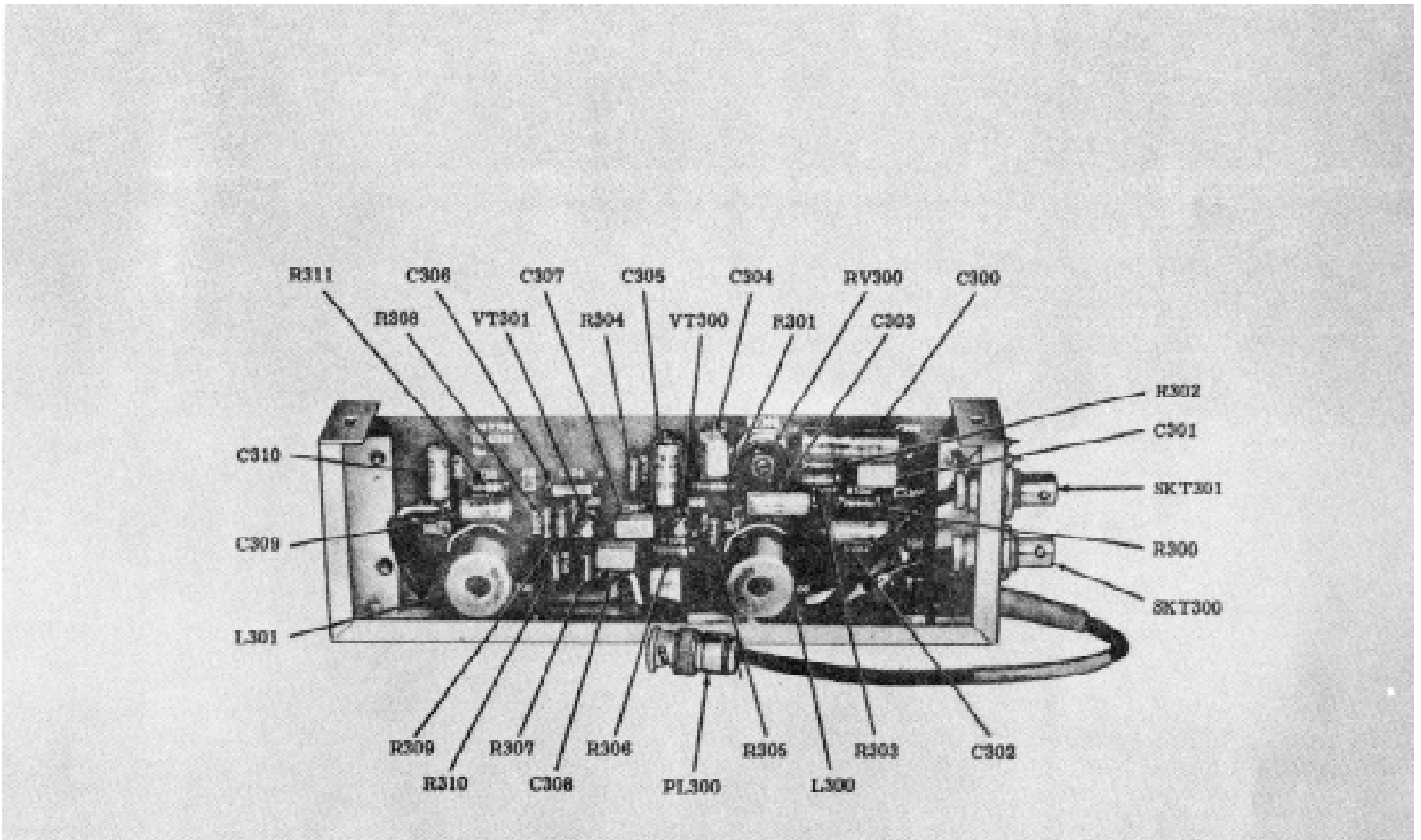

Fig. 5-11. NOISE RECEIVER, MIXER UNIT TM7672

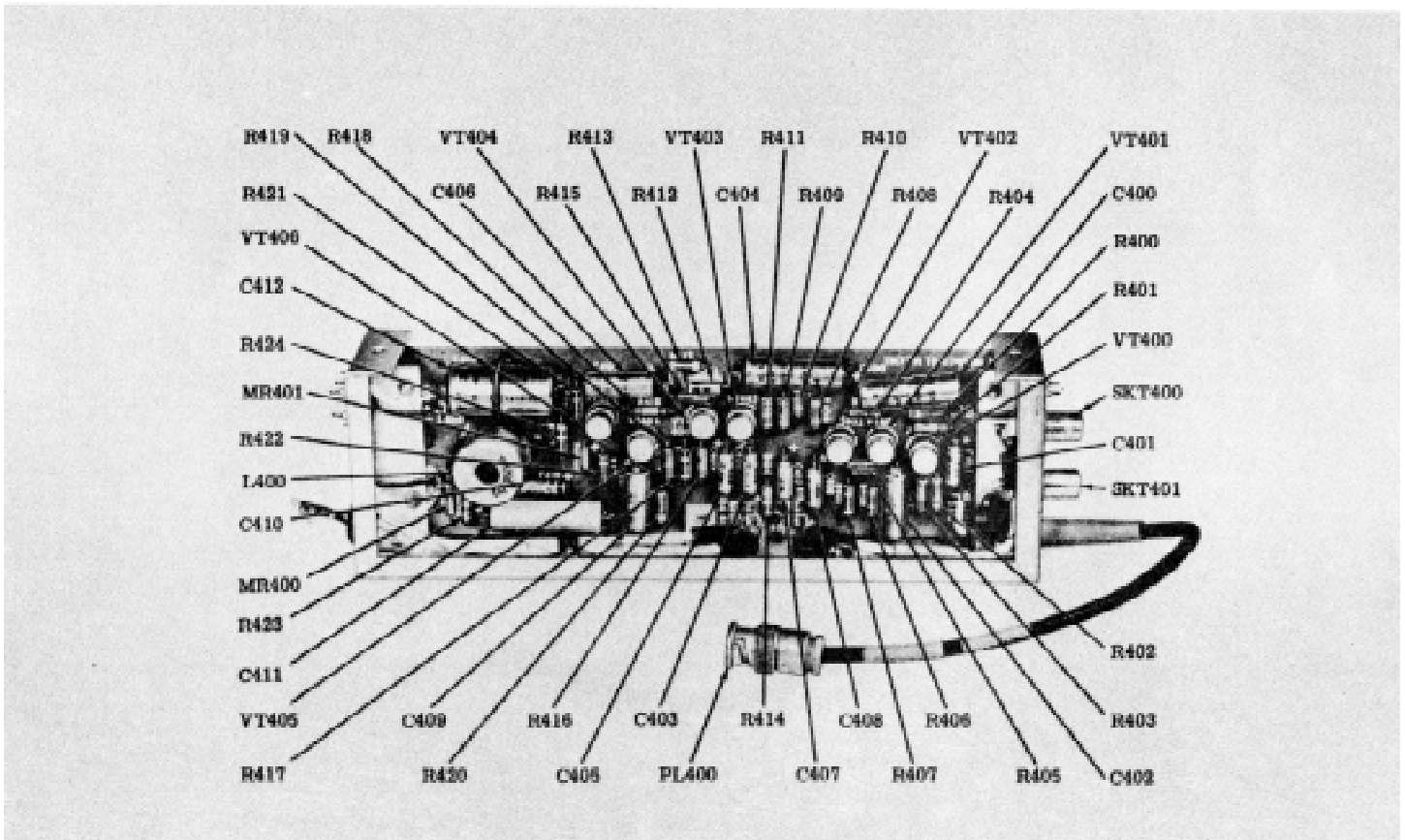

Fig. 5-12. NOISE RECEIVER, AUDIO (LF) AMPLIFIER TM7673

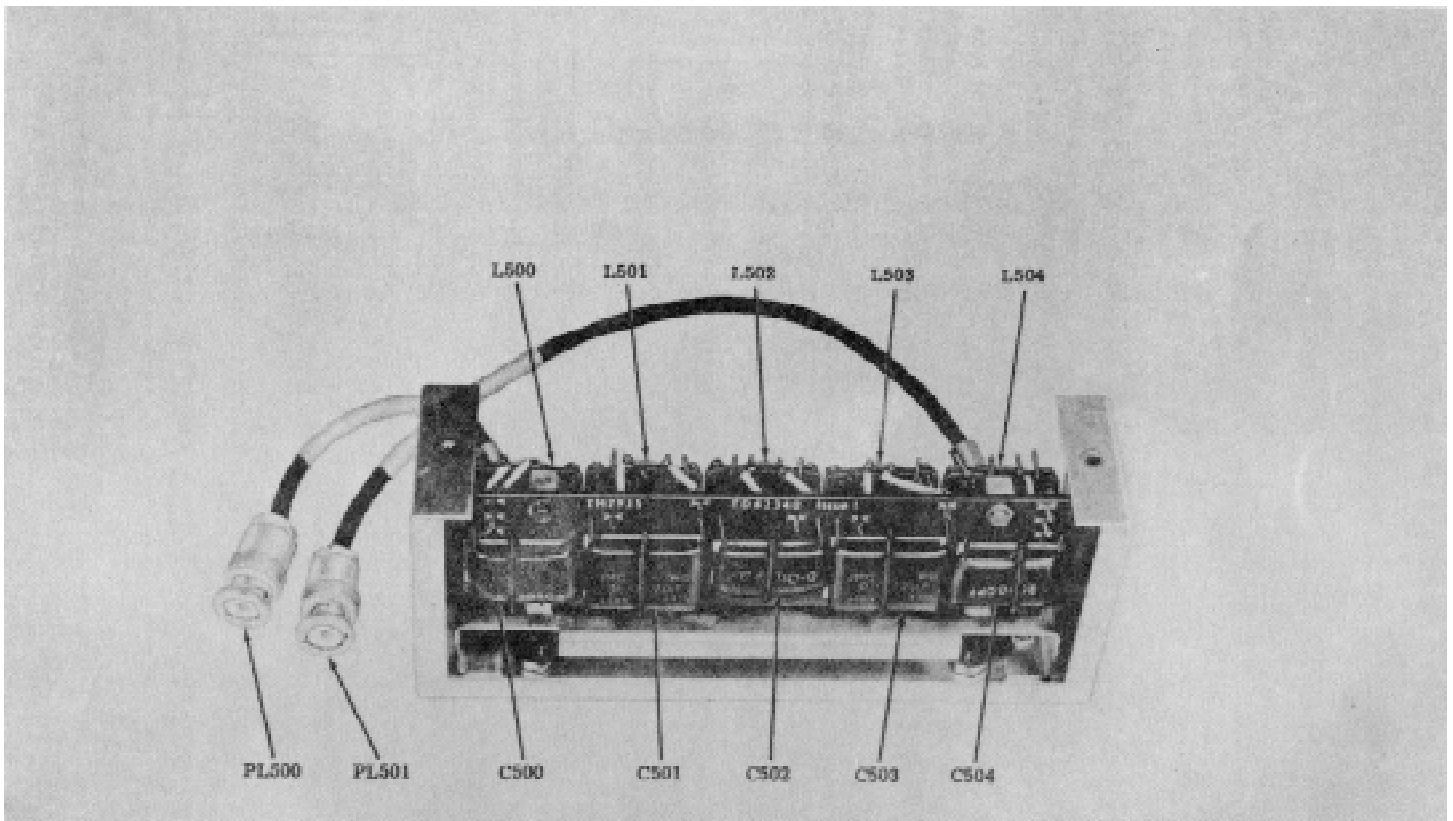

Fig. 5-13. NOISE RECEIVER, LOW FREQUENCY BAND-PASS FILTER TM7774

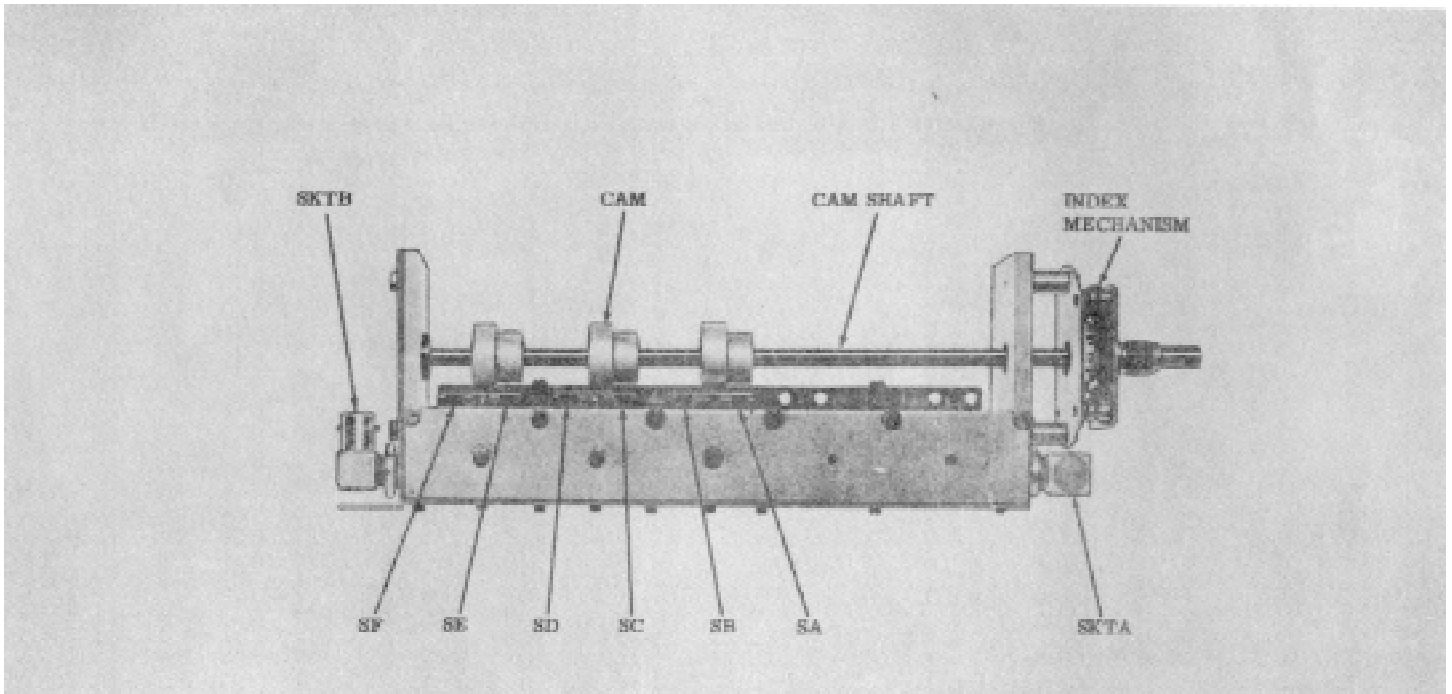

Fig. 5-14. NOISE GENERATOR, COARSE ATTENUATOR TM7787/1, SIDE VIEW

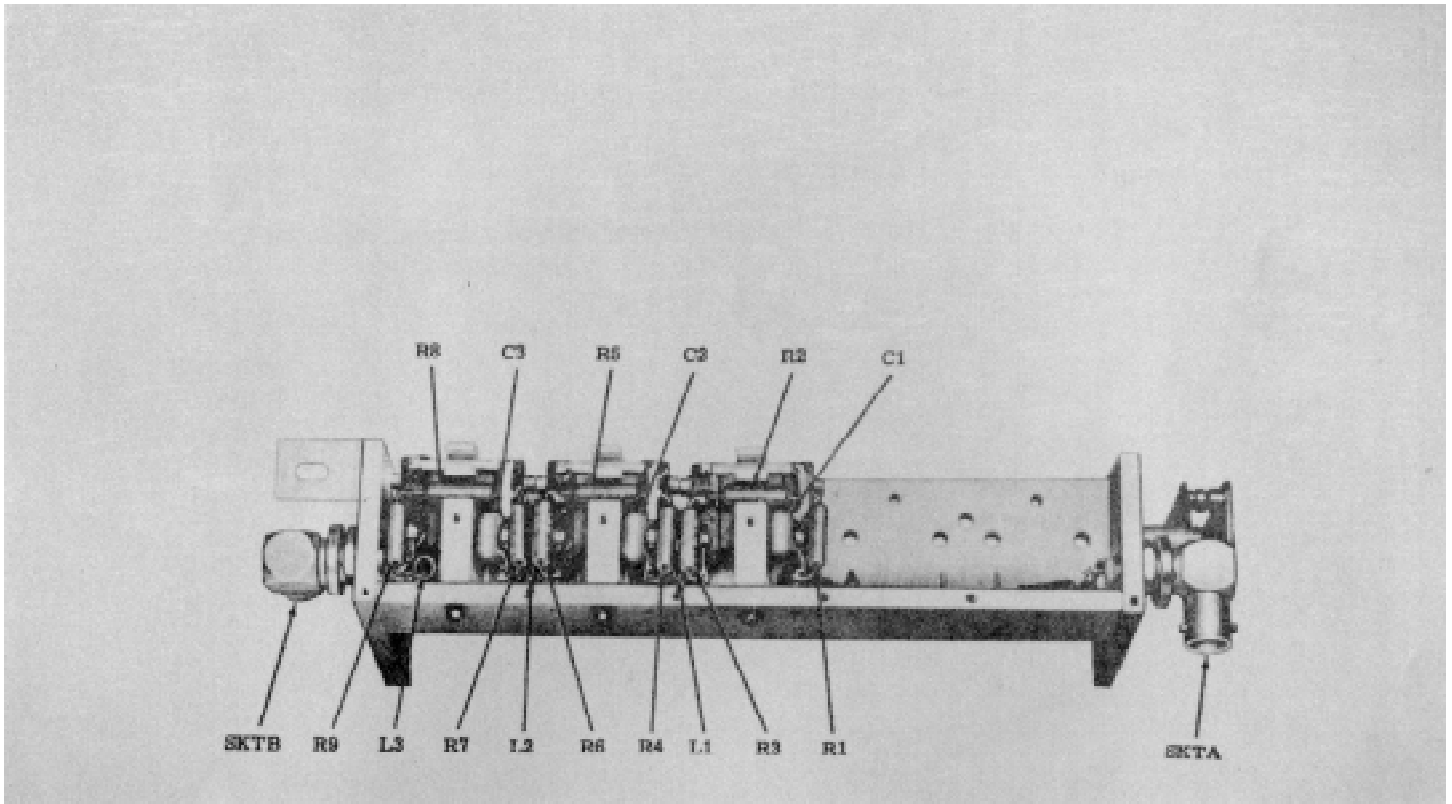

Fig. 5-15. NOISE GENERATOR, COARSE ATTENUATOR TM7787/1, BOTTOM VIEW

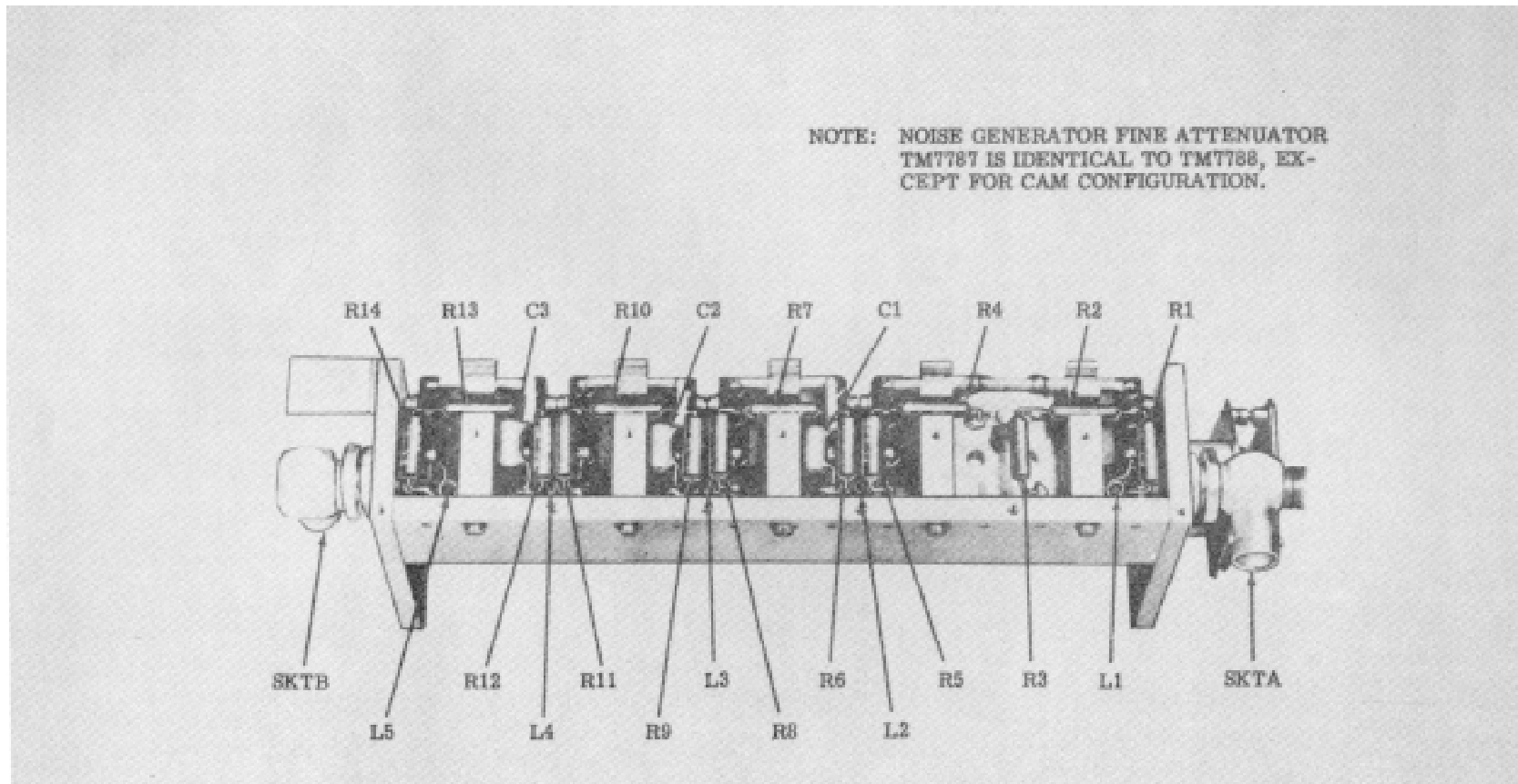

Fig. 5-16. NOISE RECEIVER, FINE ATTENUATOR TM7788, BOTTOM VIEW

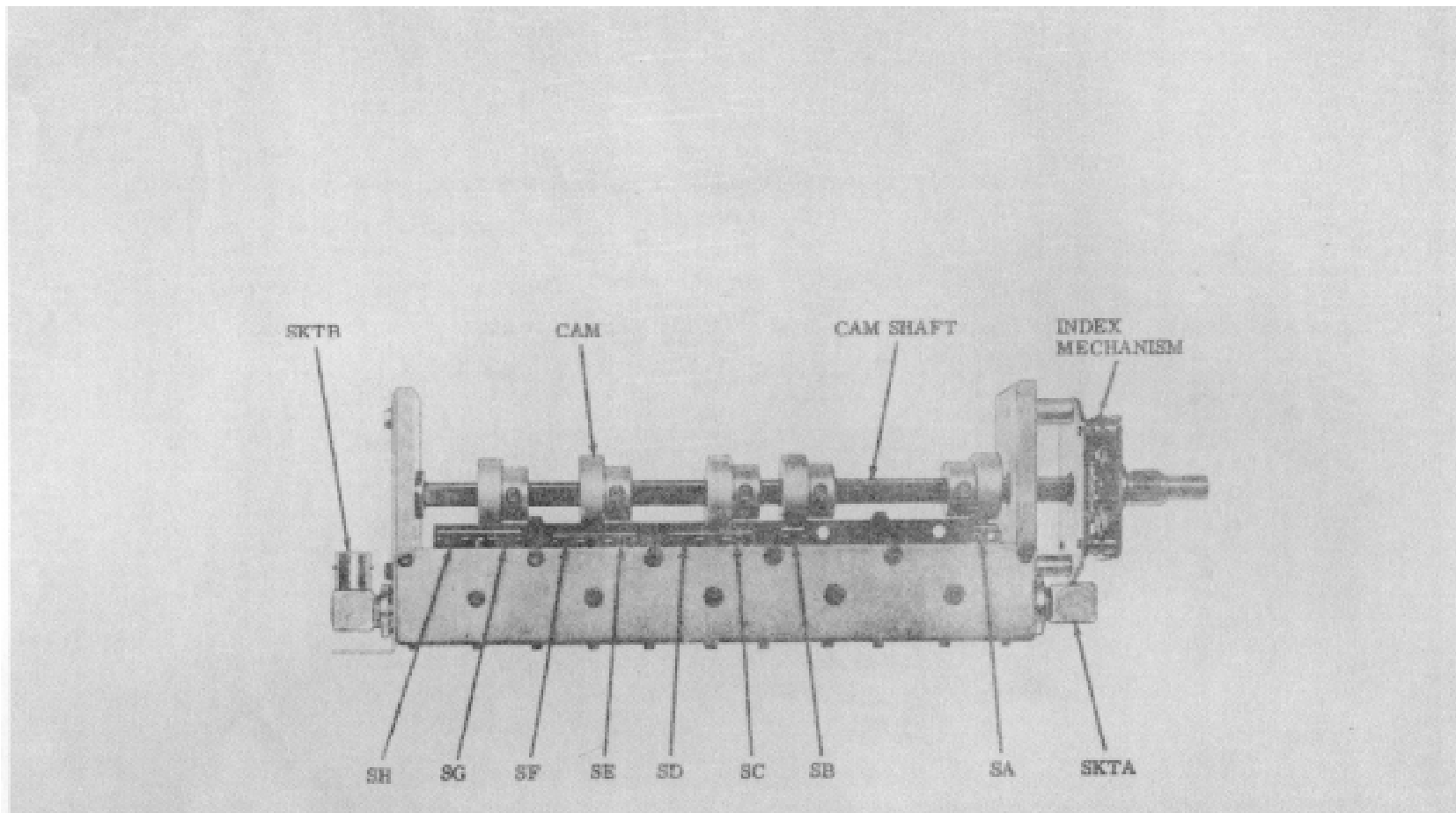

Fig. 5-17. NOISE RECEIVER, FINE ATTENUATOR TM7788 OR COARSE ATTENUATOR TM7788/1, SIDE VIEW

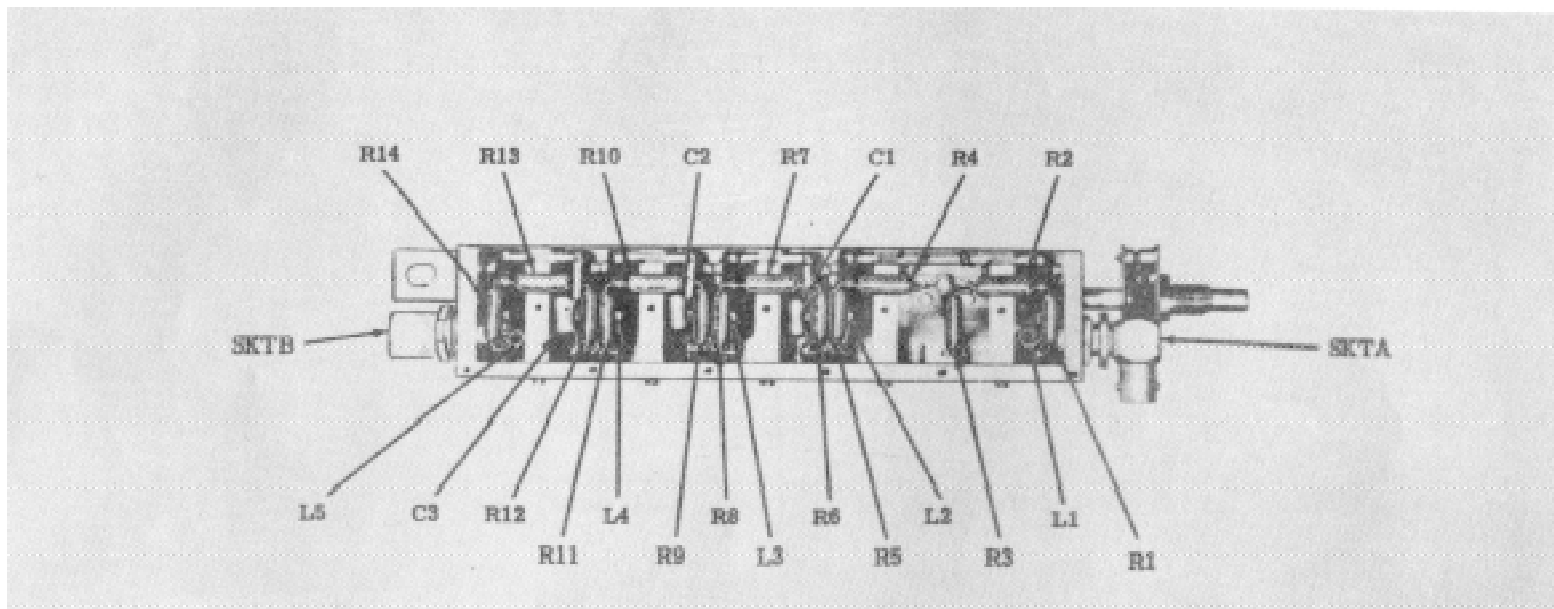

Fig. 5-18. NOISE RECEIVER, COARSE ATTENUATOR TM7788/1, BOTTEM VIEW

APPENDIX A

REFERENCES

Following is a list of publications available to the operator and maintenance personnel of Marconi OA-2090 White Noise Test Set:

DA PAM 310-4	Index of Technical Manuals, Technical Bulletins, Supply Manuals, (types 7, 8, and 9), Supply Bulletins and Lubrication Orders.
DA Pam 310-7	Index of Modification Work Orders.
SB 38-100	Preservation, Packaging, Packing and Marking Materials, Supplies, and Equipment Used by the Army.
TB 746-10	Field Instructions for Painting and Preserving Electronics Command Equipment.
TB SIG 355-1	Depot Inspection Standard for Repaired Signal Equipment.
TB SIG 355-2	Depot Inspection Standard for Refinishing Repaired Signal Equipment.
TB SIG 355-3	Depot Inspection Standard for Moisture and Fungus Resistant Treatment.
TM 9-213	Painting Instructions for Field Use.
TM 38-750	The Army Maintenance Management Systems (TAMMS)

APPENDIX B

MAINTENANCE ALLOCATION

SECTION I. INTRODUCTION

C-1. General

This appendix provides a summary of the maintenance operations covered in the equipment literature for White Noise Test Set Macron OA-2090. It authorizes categories of maintenance for specific maintenance functions on repairable terms and components and the tools and equipment required to perform each function. This appendix may be used as an aid in planning maintenance operations.

C-2. Explanation of Format for Maintenance Allocation Chart

a. Group Number. Group numbers correspond to the reference designation prefix assigned in accordance with ASA Y32.16, Electrical and Electronics Reference Designations. They indicate the relation of listed items to the next higher assembly.

b. Component Assembly Nomenclature. This column lists the item names of component units, assemblies, subassemblies, and modules on which maintenance is authorized.

c. Maintenance Function. This column indicates the maintenance category at which performance of the specific maintenance function is authorized. Authorization to perform a function at any category also includes authorization to perform that function at higher categories. The codes used represent the various maintenance categories as follows:

<u>Code</u>	<u>Maintenance Category</u>
O	Organization Maintenance
F	Direct Support Maintenance
H	General Support Maintenance
D	Depot Maintenance

Note: When this equipment is used in a fixed station or a recoverable site, the organizational (O) and direct support (F) maintenance functions are authorized to the organization operating this equipment.

d. Tools and Equipment. The numbers appearing in this column refer to specific tools and equipment which are identified by these numbers in section III.

e. Remarks. Self explanatory.

C -3. Explanation of Format for Tool and Test Equipment Requirements

The columns in the tool and test equipment requirements chart are as follows:

a. Tools and Equipment. The numbers in this column coincide with the numbers used in the tools and equipment column of the MAC. The numbers indicate the applicable tool for the maintenance function.

b. Maintenance category. The codes in this column indicate the maintenance category normally allocated the facility.

c. Nomenclature. This column lists tools, test, and maintenance equipment required to perform the maintenance functions.

d. Federal Stock Number. This column lists the Federal stock number.

e. Tool Number. Not used.

SECTION II. MAINTENANCE ALLOCATION CHART

MAINTENANCE ALLOCATION CHART														
GROUP NUMBER	COMPONENT ASSEMBLY Nomenclature	MAINTENANCE FUNCTIONS											TOLS AND EQUIPMENT	REMARKS
		INSPECT	TEST	SERVICE	ADJUST	ALIGN	CALIBRATE	INSTALL	REPLACE	REPAIR	OVERHAUL	REBUILD		
1	NOISE GENERATOR TF2091	F	H		H								None 1 thru 16	Visual High level amplifier frequency response, low level amplifier linearity, supply voltage regulation, noise diode operation
1A	HIGH LEVEL AMPLIFIER TM7639	H	H		H								16 1 thru 16	Gain, 54 volts & 26 volts, supply voltage variation, meter circuit trimmer, noise diode output level Fuss & knobs Restore to serviceable condition
1A1	CIRCUIT CARD ASSEMBLY TM7374	H	H		H								None 3 thru 9, 13	Visual Frequency response, gain, voltage
1B	LOW LEVEL AMPLIFIER TM7638	H	H		H				H				3 thru 9, 16 16 3 thru 9, 13	Frequency response, gain, continuity Frequency response and gain Replace defective parts
					H								None 3 thru 9, 13 3 thru 9, 16 3 thru 9, 13 16	Visual Linearity, gain, voltage Gain Replace defective circuit cards and parts

SECTION II. MAINTENANCE ALLOCATION CHART

MAINTENANCE ALLOCATION CHART															
GROUP NUMBER	COMPONENT ASSEMBLY NOMENCLATURE	MAINTENANCE FUNCTIONS											TOLS AND EQUIPMENT	REMARKS	
		INSPECT	TEST	SERVICE	ADJUST	ALIGN	CALIBRATE	INSTALL	REPLACE	REPAIR	OVERHAUL	REBUILD			
1B1	CIRCUIT CARD ASSEMBLY TM7315	H	H		H					H				None 3 thru 9, 13	Visual Linearity, gain, continuity, voltage Gain
1C	ATTENUATOR, VARIABLE TM7787	H	H							H	H			3 thru 9, 16 16 3 thru 9, 13	Replace defective parts
1D	ATTENUATOR, VARIABLE TM7787-1	H	H							H	H			None 1, 3 thru 9, 12 16 1, 3 thru 9, 12, 16	Visual Attenuation accuracy, switch function Replace defective parts
1E	NOISE SOURCE TM7637	H	H		H						H			None 1, 3 thru 9, 12 16 1, 3 thru 9, 12, 16	Visual Attenuation accuracy, switch function Replace defective parts
1E1	CIRCUIT CARD ASSEMBLY TM7410	H	H		H						H	H		None 5 thru 7, 15 5 thru 7, 15, 16 5 thru 7, 13, 15, 16	Visual Noise diode operation Output level, frequency response Replace defective circuit cards and parts
					H					H				None 5 thru 7, 15 5 thru 7, 15, 16 16 5 thru 7, 13, 15, 16	Visual Noise diode operation Output level, frequency response Replace defective circuit cards and parts

SECTION II. MAINTENANCE ALLOCATION CHART

MAINTENANCE ALLOCATION CHART

GROUP NUMBER	COMPONENT ASSEMBLY NOMENCLATURE	MAINTENANCE FUNCTIONS											TOLS AND EQUIPMENT	REMARKS
		INSPECT	TEST	SERVICE	ADJUST	ALIGN	CALIBRATE	INSTALL	REPLACE	REPAIR	OVERHAUL	REBUILD		
1F	FILTER, HP TM7728-1	H	H						H				None 1, 3 thru 9, 11, 12, 14, 16 16	Visual Insertion lose, cutoff
1G	FILTER, LP TM 7720-1	H	H							D			None 1, 3 thru 9, 11, 12, 14, 16 16	Note 1, Section IV Visual Insertion loss, cutoff
1H	FILTER, LP TH7720-2	H	H						H	D			None 1, 3 thru 9, 11, 12, 14, 16 16	Note 1, Section IV Visual Insertion loss, cutoff
1J	FILTER, BS TM1729-2	H	H						H	D			None 1, 3 thru 9, 11, 12, 14, 16 16	Note 1, Section IV Visual Insertion loss, stopband
1K	FILTER, BS TM7729-4	H	H						H	D			None 1, 3 thru 9, 11, 12, 14, 16 16	Note 1, Section IV Visual Insertion loss, stopband
									H		D		None 1, 3 thru 9, 11, 12, 14, 16 16	Note 1, Section IV

SECTION II. MAINTENANCE ALLOCATION CHART

MAINTENANCE ALLOCATION CHART															
GROUP NUMBER	COMPONENT ASSEMBLY NOMENCLATURE	MAINTENANCE FUNCTIONS											TOLS AND EQUIPMENT	REMARKS	
		INSPECT	TEST	SERVICE	ADJUST	ALIGN	CALIBRATE	INSTALL	REPLACE	REPAIR	OVERHAUL	REBUILD			
1L	FILTER, BS TM7729-5	H	H							H				None 1, 3 thru 9, 11, 12, 14, 16 16	Visual Insertion loss, stopband
1M	FILTER, BS TM7729-6	H	H									D		None 1, 3 thru 9, 11, 12, 14, 16 16	Note 1, Section IV Visual Insertion loss, stopband
1N	FILTER, HP TM7728	H	H							H		D		None 1, 3 thru 9, 11, 12, 14, 16 16	Note 1, Section IV Visual Cutoff, insertion loss
1P	FILTER, LP TK7720	H	H									D		None 1, 3 thru 9, 11, 12, 14, 16 16	Note 1, Section IV Visual Insertion losse, cutoff
1Q	FILTER, BS TM7729-1	H	H							H		D		None 1, 3 thru 9, 11, 12, 14, 16 16	Note 1, Section IV Visual Insertion loss, stopband
										H		D			Note 1, Section IV

SECTION II. MAINTENANCE ALLOCATION CHART

MAINTENANCE ALLOCATION CHART

GROUP NUMBER	COMPONENT ASSEMBLY NOMENCLATURE	MAINTENANCE FUNCTIONS											TOLS AND EQUIPMENT	REMARKS
		INSPECT	TEST	SERVICE	ADJUST	ALIGN	CALIBRATE	INSTALL	REPLACE	REPAIR	OVERHAUL	REBUILD		
1R	FILTER, BS TM7729-3	H	H							H		D	None 1, 3 thru 9, 11, 12, 14, 16 16	Visual Insertion loss, stopband Note 1, Section IV

SECTION II. MAINTENANCE ALLOCATION CHART

MAINTENANCE ALLOCATION CHART															
GROUP NUMBER	COMPONENT ASSEMBLY NOMENCLATURE	MAINTENANCE FUNCTIONS											TOLS AND EQUIPMENT	REMARKS	
		INSPECT	TEST	SERVICE	ADJUST	ALIGN	CALIBRATE	INSTALL	REPLACE	REPAIR	OVERHAUL	REBUILD			
2	KOISE RECEIVER, TF2092	F	H		H									None 1, 3 thru 9, 11 thru 14 3 thru 9, 11, 13, 14, 16 16	Visual Gain, frequency response, volt-ages Gain, mixer output, bias Replace fuses and knobs
2A	AMLIFIRIR, AF, TK7673	H	H		H									1, 3 thru 9, 11 thru 14, 16	Restore to serviceable condition
2A1	ELECTRONIC COMPONENT ASSEMBLY, 1M7791	H	H		H								H	None 5 thru 7, 13, 14 5 thru 7, 13, 14, 16	Visual Gain Gain Replace defective component assemblies and parts
2B	AMPLIFIER, RF, TM7671	H	H		H				H				H	None 5 thru 7, 13, 14, 16 None 3 thru 9, 11, 13 3 thru 9, 11, 13, 16 3 thru 9, 11, 13, 16	Replace defective parts Visual Gain, frequency response Gain Replace defective circuit cards and parts

SECTION II. MAINTENANCE ALLOCATION CHART

MAINTENANCE ALLOCATION CHART														
GROUP NUMBER	COMPONENT ASSEMBLY NOMENCLATURE	MAINTENANCE FUNCTIONS										TOLS AND EQUIPMENT	REMARKS	
		INSPECT	TEST	SERVICE	ADJUST	ALIGN	CALIBRATE	INSTALL	REPLACE	REPAIR	OVERHAUL			REBUILD
2B1	CIRCUIT CARD ASSEMBLY, TM7789	H	H		H				H	H			None 3 thru 9, 11, 13 3 thru 9, 11, 13, 16 16 3 thru 9, 11, 13, 16	Visual Gain, frequency response Gain Replace defective parts
2C	ATTENUATOR, VARIABLE, TM7788	H	H							H			None 1, 3 thru 9, 12 1, 3 thru 9, 12, 16	Visual Step attenuation accuracy, switch function Replace defective parts
2D	ATTENUATOR, VARIABLE, TM-7788-1	H	H							H			None 1, 3 thru 9, 12 1, 3 thru 9, 12, 16	Visual Attenuation accuracies, switch function Replace defective parts
2E	MIXER STAGE, TM7672	H	H		H					H			None 1, 5 thru 7, 11 thru 14 5 thru 7, 13, 16 1, 5 thru 7, 11 thru 14, 16	Visual Mixer efficiency, continuity, voltages Mixer bias Replace defective circuit cards and parts
2E1	CIRCUIT CARD ASSEMBLY, TM7790	H	H		H				H	H			None 1, 5 thru 7, 11 thru 14 5 thru 7, 13, 16 16 1, 5 thru 7, 11 thru 14, 16	Visual Mixer efficiency, continuity, voltages Mixer bias Replace defective parts

SECTION II. MAINTENANCE ALLOCATION CHART

MAINTENANCE ALLOCATION CHART															
GROUP NUMBER	COMPONENT ASSEMBLY NOMENCLATURE	MAINTENANCE FUNCTIONS											TOLS AND EQUIPMENT	REMARKS	
		INSPECT	TEST	SERVICE	ADJUST	ALIGN	CALIBRATE	INSTALL	REPLACE	REPAIR	OVERHAUL	REBUILD			
2F	FILTER, BP, TM7730-2	H	H						H					None 1, 3 thru 9, 11, 12, 14 16	Visual Passband, insertion loss, continuity
2G	FILTER, BP, TM7730-4	H	H						H				D	None 1, 3 thru 9, 11, 12, 14 16	Note 1, Section IV Visual Passband, insertion loss, continuity
2H	FILTER, BP, TH7730-5	H	H						H				D	None 1, 3 thru 9, 11, 12, 14 16	Note 1, Section IV Visual Passband, insertion loss, continuity
2I	FILTER, BP, TM7730-6	H	H						H				D	None 1, 3 thru 9, 11, 12, 14 16	Note 1, Section IV Visual Passband, insertion loss, continuity
2K	FILTER, BP, TH7730-1	H	H						H				D	None 1, 3 thru 9, 11, 12, 14 16	Note 1, Section IV Visual Passband, insertion loss, continuity
2L	FILTER, BP, TM7730-3	H	H						H				D	None 1, 3 thru 9, 11, 12, 14 16 Note I, Section IV	Note 1, Section IV Visual Passband, insertion loss, continuity

SECTION III. TOOL AND TEST EQUIPMENT REQUIREMENTS

TOOL AND TEST EQUIPMENT REQUIREMENTS				
TOOLS AND EQUIPMENT	MAINTENANCE CATEGORY	NOMENCLATURE		FEDERAL STOCK NUMBER
		RECOMMENDED IN MANUAL	U.S. EQUIVALENT	
1	H	Multirange DC Voltmeter, Avometer Model 8	Multimeter, Simpson 260	
2	H	Variable Mains Transformer, Variac		
3	H	Sweep Generator, 15 MHz, Marconi TF1099	Sweep/Signal Generator, Telonic SM-2000-1	
4	H		Plug-In Oscillator, Telonic Model VR-2M	
5	H	Oscilloscope, 15 MHz bandwidth	Oscilloscope, Hewlett Packard Model 175A	
6	H		Oscilloscope Plug-In, Hewlett Packard 1752A	
7	H		Oscilloscope Plug-In, Hewlett Packard 1780A	
8	H	RF Step Attenuator 0 to 60 dB in 1 dB steps, Marconi Instruments Type TF1073A	Variable Coaxial Attenuator, Hewlett Packard Model 355C	
9	H		Variable Coaxial Attenuator, Hewlett Packard Model 355D	
10	H	Power Meter, 75 ohms-15 mc, 100 mW $\pm 1/4$ dB	RMS Voltmeter, Hewlett Packard Model 3400A	
11	H	Signal Generator, 10 kHz to 15 MHz, Marconi Instruments TF144H	Signal Generator, Hewlett Packard Model 606A	
12	H	Counter, Marconi Instruments TF1417	Frequency Counter, Hewlett Packard Model 5245L	
13	H	Valve Voltmeter, dc to 15 MHz, Marconi Instruments Type TF1041C	VTVM, Hewlett Packard Model 410B	
14	H	Audio Oscillator, to 700 Hz, Marconi Instruments Type TF2001	Audio Oscillator, Hewlett Packard Model 200CD	
15	H	Tunable Level Meter, 75 ohms		
16	O, H		Tool Kit, Technicians, Radio	

SECTION IV. - REMARKS

REMARKS

REFERENCE CODE	REMARKS
	<p>Note: 1. Return to depot for further disposition.</p>

W. C. WESTMORELAND,
*General, United States Army,
 Chief of Staff.*

Official:

VERNE L. BOWERS,
*Major General, United States Army,
 The Adjutant General.*

Distribution:

Active Army:

CNGB (1)	USAESC (25)
USASA (2)	USA ASCOM Depot (3)
USAMB (10)	USA Cp Carroll Depot (3)
ACSC-E (2)	USASTRATCOM Sig Gp, Japan (3)
USACDCEC (5)	USASTRATCOM Comm Op Bn, Korea (2)
USACDCCEA (1)	USA Depot, Cam Rahn Bay (3)
USACDCCEA Ft Huachuca (1)	USA Depot, Long Binh (3)
OS Maj Comd (2)	USA Depot, Qui Nhon (3)
USASTRATCOM (5)	Units org under fol TOE:
USASTRATCOM (PAC) (10)	(2 copies each)
USASTRATCOM-SIG-GP-T (5)	11-15
USASTRATCOM-CONUS (5)	11-45
LOGCOMD (5)	11-97
Eighth USA (10)	11-98
USARV (10)	11-158
USASUPCOM-CRB (5)	11-302
USASUPCOM-QN (5)	11-303
USASUPCOM-SGN (5)	11-347
USARYIS (5)	11-357
ICC (3)	11-367
1st Sig Bde (10)	11-368
Sig FLDMS (1)	11-377
SAAD (10)	11-500 (AA-AC)
TOAD (10)	29-118
LEAD (7)	29-134
USACSA (2)	29-136
USATECOM (2)	29-137

NG: None.

USAR: None.

For explanation of abbreviations used, see AR 310-50.

Fig. 4.12 Generator Inter-unit wiring

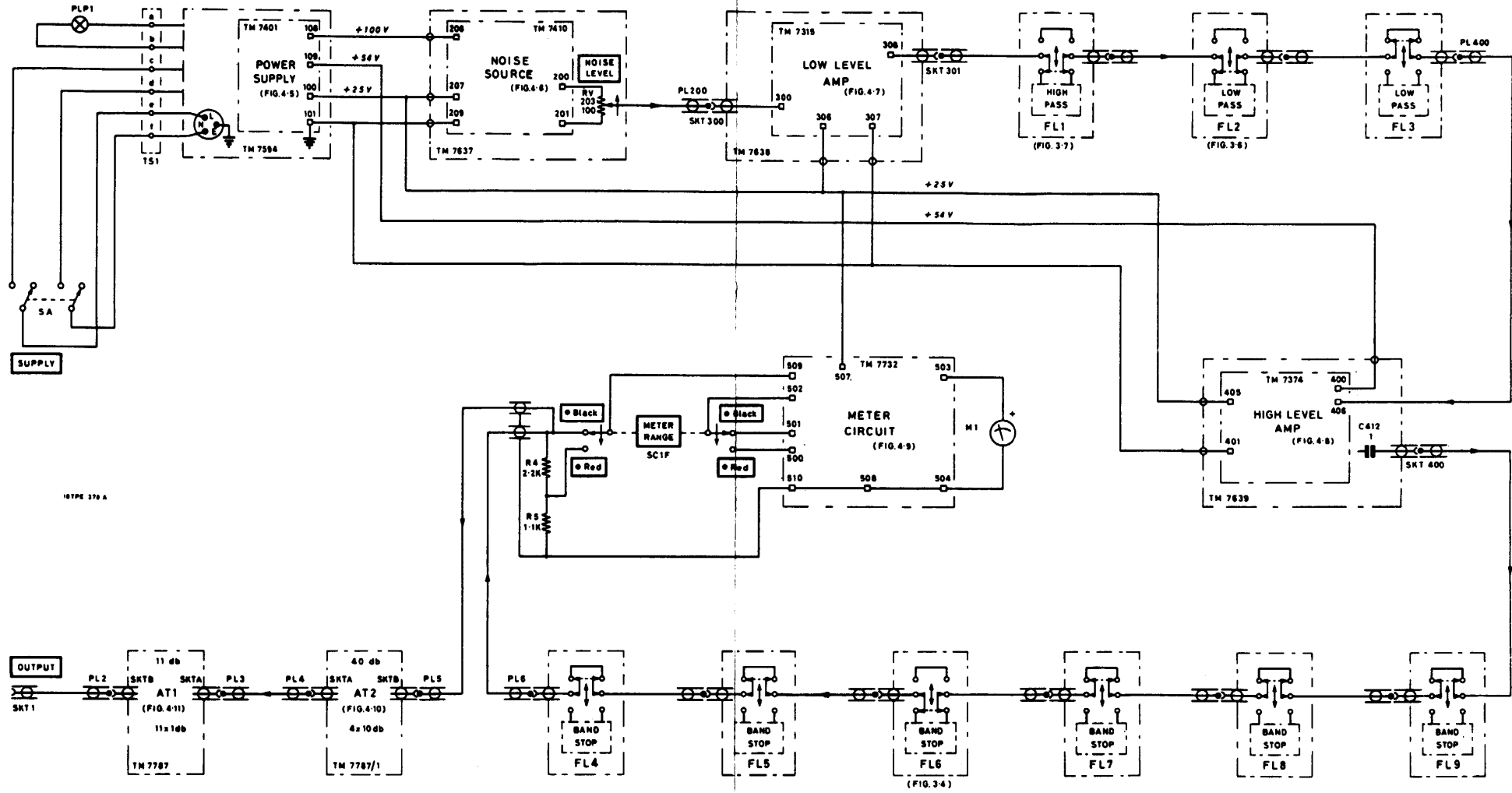

Fig. 4.12. Generator Inter-unit wiring.

Fig. 4.20 Receiver inter-unit wiring

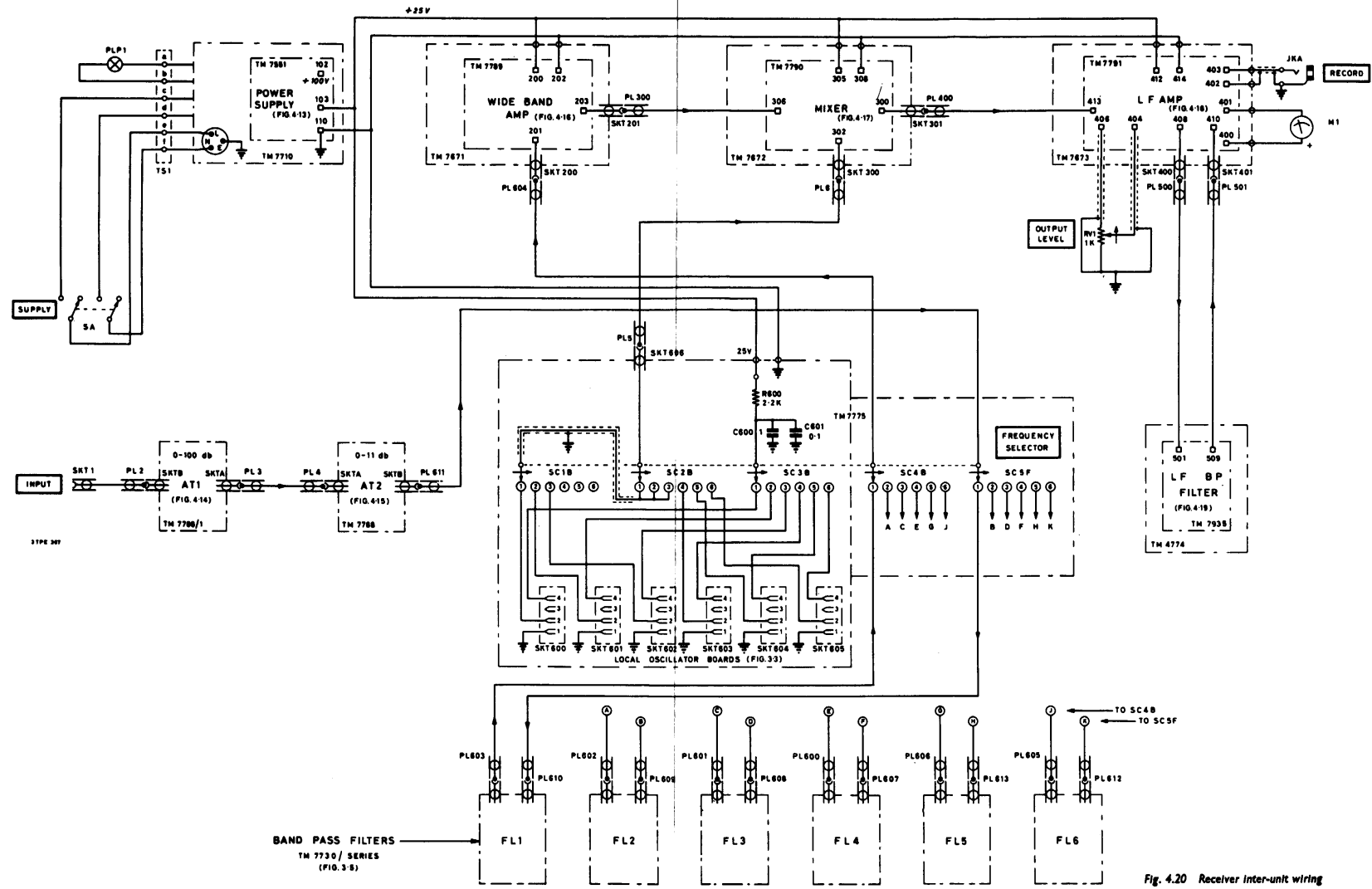

Fig. 4.20 Receiver inter-unit wiring

Fig. 4.20. Receiver Inter-unit wiring

RECOMMENDED CHANGES TO EQUIPMENT TECHNICAL PUBLICATIONS



THEN... JOT DOWN THE DOPE ABOUT IT ON THIS FORM, CAREFULLY TEAR IT OUT, FOLD IT AND DROP IT IN THE MAIL!

SOMETHING WRONG WITH THIS PUBLICATION?

FROM: (PRINT YOUR UNIT'S COMPLETE ADDRESS)

DATE SENT

PUBLICATION NUMBER

PUBLICATION DATE

PUBLICATION TITLE

BE EXACT... PIN-POINT WHERE IT IS

PAGE NO.

PARA-GRAPH

FIGURE NO.

TABLE NO.

IN THIS SPACE TELL WHAT IS WRONG AND WHAT SHOULD BE DONE ABOUT IT:

TEAR ALONG PERFORATED LINE

PRINTED NAME, GRADE OR TITLE, AND TELEPHONE NUMBER

SIGN HERE:

DA FORM 2028-2
1 JUL 79

PREVIOUS EDITIONS ARE OBSOLETE.

P.S.—IF YOUR OUTFIT WANTS TO KNOW ABOUT YOUR RECOMMENDATION MAKE A CARBON COPY OF THIS AND GIVE IT TO YOUR HEADQUARTERS.

